

# Ingersoll Rand

Air Motors





# Repairs Done Right. Service Made Simple.

Proper service of Ingersoll Rand/ARO air motors with quality-authorized parts will help prevent wear and tear, eliminate downtime and extend a product's life. That's why Ingersoll Rand (IR) has created a program that provides service and repairs to the end user through the use of Authorized Service Agents.

This newly developed program ensures that Ingersoll Rand maintenance and repair standards are met, through the use of genuine parts and service. Whether it's serious technical difficulties or just routine maintenance, products can be taken directly to any specified Authorized Service Agent. From there, the program has been set up to make certain that the air motor is put into the hands of reliable, fully trained IR service technicians. This process ensures that you have access to the expertise and resources of a full service center, regardless of geographic location.

## **Program Features:**

- One Face to the End User
- Quality repairs using genuine IR parts
- Access to an IR owned service center
- Fully trained service technicians using IR specified testing equipment
- Receive your quote in 48 hours or less
- 90 day repair warranty

# Contents

## In-Line Planetary Gear, Multi-Vane Air Motors ..... 9

0000-Series	9
M002 Series	11
000-Series	14
M004 Series	16
0-Series with 0-Series Gearing	19
0-Series with 2200 Series Gearing	21
M007 Series	23
2200-Series with Thread-On Gearing	27
2200-Series with Bolt-On Gearing	29
2200-Series with 44-Series Gearing	31
1801 and 1841 Series	33
3800 and 3840 Series	35
44-Series	37
4800 and 4840 Series	39



0.10 – 3.80 hp

## Spur Gear, Multi-Vane Motors ..... 41

17RA, 17RB, 34RA and 34RB Series	41
48RA and 48RB Series	43
92RA and 92RB Series	45
92RM and 992RM Series	47



2.20 – 9.90 hp

## Direct Drive Multi-Vane Motors ..... 49

MVA and MOV0 Series	49
Series Lube Free	53



0.33 – 10.5 hp

## Rotary-Vane Pneumatic Milling and Sawing Motors ..... 60

Overview and Reference Chart	60
000-Series Milling Motors	62
0-Series Milling Motors	64
2200-Series Milling Motors	66
2200-Series Milling Motors (Straddle Mount)	68
2200-Series Milling Motors (Side Mount)	69
44-Series Milling Motors	70



0.25 – 2.00 hp

## Specially Governed Motors ..... 72

Model 22N51-W/RC	72
Series 551	73

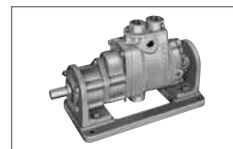

1.75 – 5.60 hp

## Direct and Geared Drive Piston Air Motors ..... 74

CC – KK Series	74
MMP150 Series	79
KK5B Series	81



2.05 – 30.00 hp

## Components, Equipment and Accessories ..... 84

Filters, Regulators and Lubricators	84
Accessories	87
Installation of Reversible Models	88
Warranty	89
Index by Model Number	90
Contact Information	97



## Introduction

For more than 125 years, Ingersoll Rand has been an industry leader in engineering and manufacturing air power. Ingersoll Rand is the expert in air power.

### Air Power

Creating sheer power from the natural environment, Ingersoll-Rand air motors are flexible, efficient alternatives to electric sources—perfect for a wide range of industrial applications. Consider these advantages:

- *Infinitely variable speeds and torques* via pressure regulation or air valves—no costly controls required
- *Instant starting, stopping and reversing* eliminates the delays of motor speed-up or slow-down periods
- *Will not overheat or burn out*, even when overloaded or run to stall
- *Safe operation in hazardous conditions*, with no electrical sparks or hydraulic fluids
- *Cool running characteristics minimize* the effects of hot, wet or dusty surroundings
- *Low maintenance*, based on simplicity of design and strength of construction
- *Excellent design flexibility*—a function of compact size, light weight, and high power output
- *Temperature range*—up to 150°F with standard lubrication and up to 300°F with high temperature lubrication



### Full Spectrum of Solutions

Ingersoll Rand offers well over 200 cataloged models of air motors, with an extensive range of options:

- *Reversible and non-reversible types*
- *Vane or piston configurations*
- *Geared and non-geared varieties*
- *0.10 to 30 horsepower*
- *23 rpm to 26,000 rpm speed ratings*
- *0.10 ft-lb. to 1090 ft-lb. torque ratings*

In addition, Ingersoll Rand maintains data on hundreds of special application air motors that have solved problems for design engineers around the world over the years. You can access this invaluable resource by contacting your Ingersoll Rand representative or distributor with details of your situation.

With over 125 years of engineering and manufacturing leadership, Ingersoll Rand is the expert in air power.





## Air Motor Performance Curves

The performance curves shown throughout this catalog can assist you in matching specific air motor models to requirements. Performance data within one series may vary slightly, depending on gear ratios. When this occurs, median performance for that series is indicated. Follow these guidelines for interpreting the performance curves:

### Horsepower

1. Locate operating speed on the correct horizontal axis of the bottom chart
2. Read Horsepower from the correct curve in the bottom chart

### Torque

1. Locate operating speed on the correct horizontal axis of the bottom chart
2. Read Torque from the correct curve in the bottom chart

### Air Consumption

1. Locate operating speed on the correct horizontal axis on the bottom chart
2. Read Air Consumption from the correct curve in the top chart

### Maximum Allowable Shaft Radial Load

- On applications where Shaft Radial Load is a factor:
1. Locate operating speed on the horizontal axis of the top chart
  2. Read Shaft Radial Load on the correct Load Curve in the top chart

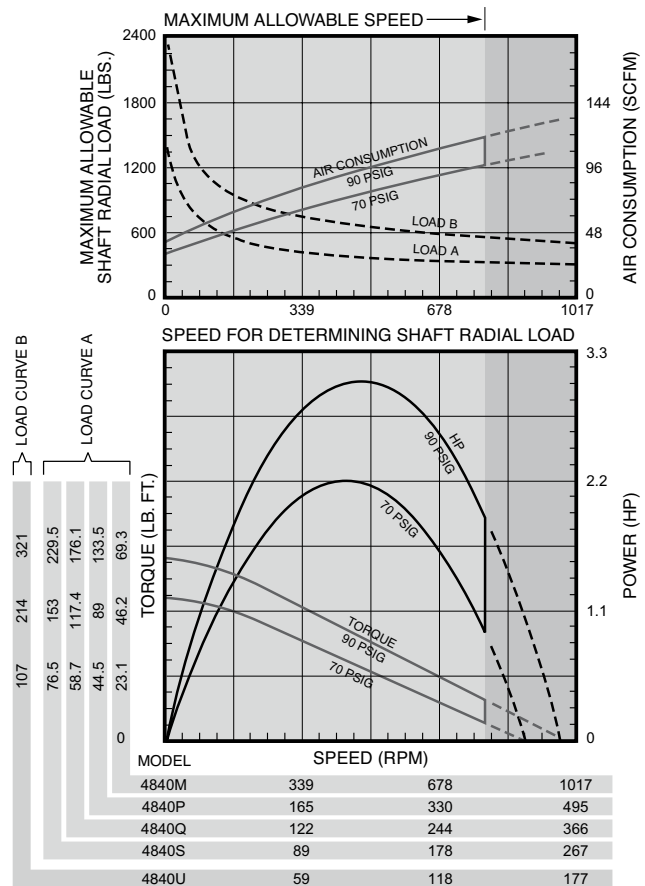

### Two 1/3 Horsepower Motors

The Ingersoll Rand reversible Series M004 Air Motor shown weighs only 2 3/8 lbs. It has integral gear reduction of 33 to 1 and a free speed of 450 rpm. The comparable horsepower 110 volt electric motor, with a free speed of 1725 rpm, weighs 15 1/2 lbs.



## Air Motor Selection and Characteristics

Ingersoll Rand offers two basic types of Air Motor:

### Vane Motors

Are smaller, lighter and less expensive than piston motors of similar power. Simple in design and construction, they can be operated in most any position. Vane motors are available in a broad range of speeds, torques and power and are the most widely used type of air motor.

### Radial Piston Motors

Operate at lower speeds than vane motors. Have excellent starting and speed control. Especially good for “lugging” heavy loads at slow speed. Standard operational position is horizontal.

### Reversible/Non-Reversible Air Motors

Non-reversible air motors are rated at slightly higher speeds, torques, and horsepower than reversible motors of the same family.

### Air Pressure

When selecting air motors, remember that the specification listings show only one set of performance figures, at a particular pressure —90 psig. Air motors are designed to produce optimum performance at this pressure.

Many other speeds, torques and power can be obtained from the same motor by regulating the pressure, air supply or exhaust. While they will operate at pressures below 40 psig, their performance may not be consistent. They can also be operated above 100 psig, but often at the expense of increased maintenance.

A good rule to follow is to size an air motor based on approximately 70% of the lowest available air pressure. This will allow additional power for starting and possible overloading. See page 5 for performance characteristics at various air pressures.

### Maximum Power

Ungoverned air motors develop maximum horsepower at approximately 50% of free (unloaded) speed while governed motors reach their peak horsepower at about 80% of free speed. The only governed motors in this catalog are the 22 and 55 Series.

### Desired Operating Speed

The desired operating speed, not the free and unloaded speed should be considered when selecting air motors.

Ungoverned air motors should not be run unloaded. The performance curves in this catalog indicate the maximum speeds at which the motor should be operated. The nameplate stamped speed is present for identification only.

### Required Torque

Equally important as the speed at which an air motor is to be run is the required torque. The combination of the two factors—speed and torque—determine the power of the desired motor. Care should be taken to differentiate between stall (maximum) and running torques when selecting air motors.

### Speed and Torque

Starting torques are approximately 75% of stall torques.

Operating or running torques at any speed can be approximated from motor performance curves—or calculated using the formula:

$$\text{Torque (lb-ft)} = \frac{\text{Horsepower} \times 5250}{\text{speed (revolutions per minute)}}$$

$$\text{Torque (Nm)} = \frac{\text{Kilowatts} \times 9550}{\text{speed (revolutions per minute)}}$$

### Speed and Torque

When an air motor is to be used with a pulley, sprocket, or gear on the shaft, the overhung load (perpendicular to the shaft), commonly called “shaft radial loading” must be considered. It is shown in the performance curves and is generally assumed to be applied at the mid-point of the keyway of the shaft.

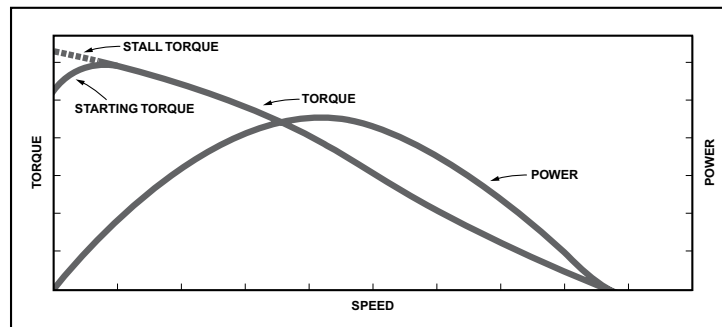

Fig. 1. Torque and power curves for a typical air motor. Torque is maximum at zero speed and zero at free speed. Any loading will slow the motor. As the load increases, the speed decreases and the torque increases until the motor stalls. If the load is decreased, the motor speed increases and its torque output decreases to match the applied load.



## Air System and Supply

Once an air motor has been selected, it is important to ensure that the desired air pressure is available at the motor, *while the motor is operating*. A pressure reading at the compressor does not mean that the same pressure will be available to an operating air motor, because of possible restrictions and friction losses in the air system. Exhaust restrictions can also affect air motor operation, and are often the cause of performance problems.

## Inlet Controls

When installing reversible air motors, a four-way valve or two three-way valves should be used to prevent blockage of the secondary Exhaust Port. This is the opposite Rotation Port to that which is being pressurized.

## Replacing Electric Motors with Air Motors

Electric motors, with the exception of series wound direct current motors, have entirely different performance characteristics than air motors. Therefore, their torque and speed curves will not match. Many electric motors are oversized to allow for overloading and lower power air motors can be used as replacements.

## Ingersoll Rand Assistance

Your Ingersoll Rand Air Motor distributor and factory representative are anxious to help with motor problems, applications and selections.

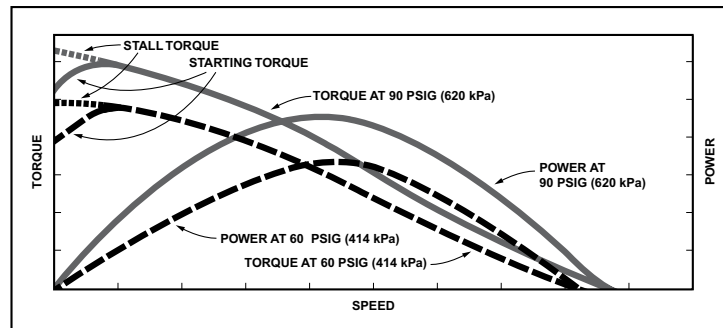

Fig. 2. Typical Air Motor torque and power curves at two different air pressures. Note that speed, torque and power decrease as the air pressure decreases.

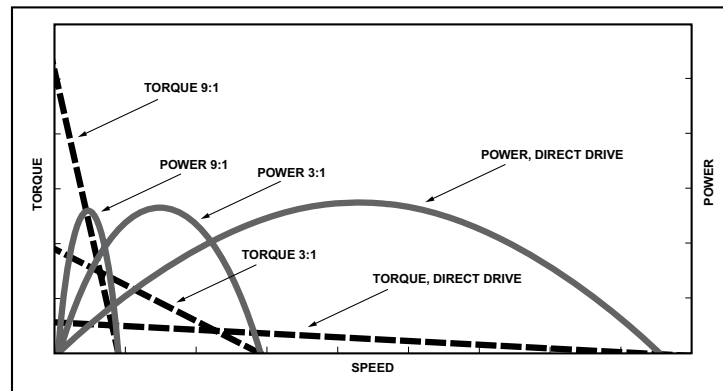

Fig. 3. Torque and power curves for geared and nongearred motors. Note that reducing rpm by gearing steepens the torque curve while maintaining power. Gearing is often used to reduce the speed and increase the torque of air motors. The greater the gear reduction, the steeper will be the torque curve; thus, the higher speed motor will be more susceptible to a drop in speed as a load is applied than the slower speed motor with additional gearing.

## Varying Air Pressure

### How to Determine Performance Characteristics at Air Pressures Other than 90 psig

As air pressure changes, the performance characteristics will change by the percentages given below.

#### Ungoverned Air Motors

Air Pressure (psig)	Free Speed (rpm)	Air Consumption at Free Speed (scfm)	Maximum Power (hp)	Speed at Maximum Horsepower (rpm)	Torque at Maximum Horsepower (lb.-ft.)	Air Consumption at Max. Power (scfm)	Stall or Starting Torque (lb.-ft.)
40	80%	45%	30%	80%	37.5%	45%	45%
50	84%	56%	44%	84%	52.4%	56%	56%
60	88%	67%	58%	88%	65.9%	67%	67%
70	92%	78%	72%	92%	78.3%	78%	78%
80	96%	89%	86%	96%	89.6%	89%	89%
90	100%	100%	100%	100%	100.0%	100%	100%
100	104%	111%	114%	104%	109.6%	111%	111%

**Example:** Knowing the performance characteristics of a Model 3840P reversible ungoverned Air Motor at 90 psig (620 kPa) it is a simple matter to determine its characteristics at another air pressure. Using the percentages from the table for 60 psig (414 kPa), the performance becomes:

Characteristic	Performance at 90 psig	Percentage Reduction	Performance at 60 psig
Maximum Power (hp)	1.35	x 58% =	.78
Free Speed (rpm)	440	x 88% =	387
Speed at Max Power (rpm)	215	x 88% =	189
Max (Stall) Torque (lb.-ft.)	53.5	x 67% =	35.8
Torque at Max Power (lb.-ft.)	33	x 65.9% =	21.7
Starting Torque (lb.-ft.)	40	x 67% =	26.8
Air Consumption at Free Speed (scfm)	54	x 67% =	36.2
Air Consumption at Max HP (scfm)	44	x 67% =	29.5

#### Air Supply or Exhaust Regulation

Reducing or restricting the amount of air supplied to the motor has a similar effect to reducing the air pressure.

Choking or restricting the exhaust has a somewhat different effect, with the speed decreasing much more than the torque.

The effects of changes in pressure, air supply and exhaust regulation are summarized in the table at the right:

Exact variations in performance with “choked” motors are not tabulated; however, “on the job” tests will usually produce the desired results; sometimes from a combination of pressure adjustments and inlet and exhaust restrictions.

Air Regulation	Speed	Torque
Reduced air pressure, or restricting volume of air to motor	Reduced	Greatly Reduced
Choking or restricting exhaust	Greatly Reduced	Reduced



# In-Line Planetary Gear, Multi-Vane Air Motors

## 0000-Series

### Specifications

MODEL	SPINDLE	R.P.M.		TORQUE OUTPUT				AIR CONSUMPTION		SOUND LEVEL @FREE SPEED dB(A)	WEIGHT		GEAR REDUCTION
		FREE SPEED	LOAD SPEED @MAX. H.P.	STALL lb. ft.	Nm	@MAX. H.P. lb. ft.	Nm	@FREE SPEED SCFM	L/s		lbs.	kg.	
<b>NON-REVERSIBLE - .10 H.P.</b>													
8610-A	3/8" Keyed	1,000	500	1.8	2.4	1.05	1.4	9.5	4.5	80	90	.40	Double
8611-A	3/8" Keyed	5,000	2,500	.42	.6	.21	.3	9.5	4.5	80	80	.36	Single
8616-A	3/8"-24 Th'd.	1,000	500	1.8	2.4	1.05	1.4	9.5	4.5	80	.90	.40	Double
8617-A	3/8"-24 Th'd.	5,000	2,500	.42	.6	.21	.3	9.5	4.5	80	.80	.36	Single
8618-A	3/8"-24 Th'd.	25,000	13,000	.10	.1	.04	.05	9.5	4.5	80	.80	.36	Single
<b>REVERSIBLE - .10 H.P.</b>													
8613-A	3/8" Keyed	1,000	500	1.8	2.6	1.05	1.4	11.5	5.4	80*	.90	.40	Double
8614-A	3/8" Keyed	5,000	2,500	.42	.6	.21	.3	11.5	5.4	80*	.80	.36	Single

\* Requires installation for reversible motors - shown on page 88.

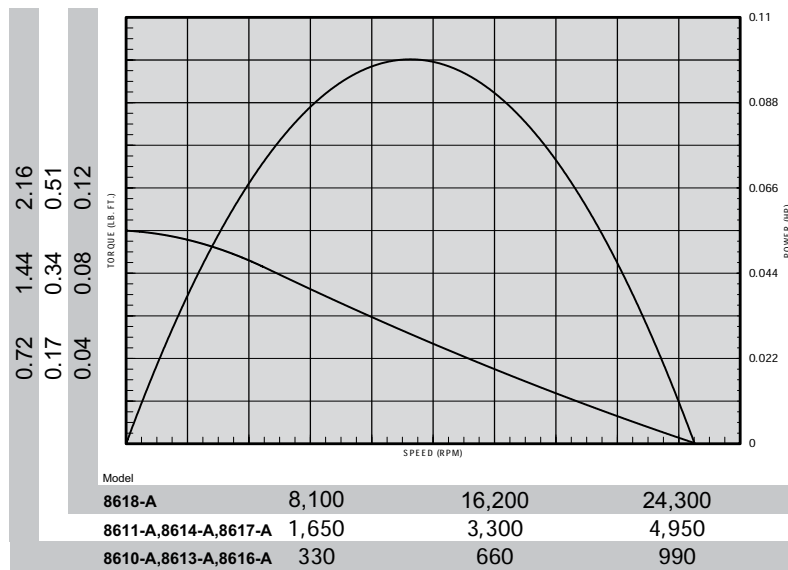

### Standard Equipment

Steel motor housing, flush-type grease fittings at rotation points for gear and bearing lubrication, exhaust manifold rotatable within 360°, and muffler.



### Equipment Options

41058 Flange Bracket

41057 Foot Bracket



41058



41057

### Options for Motors with Thread Spindles

30384-5 3/8" (9.5 mm) Male Square-Drive Adapter

30384-9 1/2" (12.7 mm) Male Square-Drive Adapter

30712 1/4" (6.4 mm) Female Hex Ball-Lock Adapter for screwdriver bits

47340 1/4" (6.4 mm) Capacity Drill Chuck

## 0000-Series and Mounting Accessory Dimensions

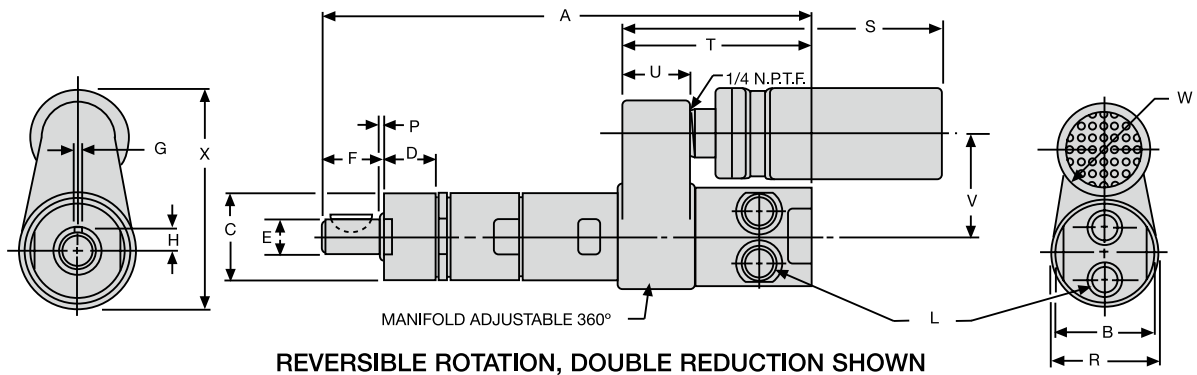

Gear Reduction	DIMENSION A			
	Models 8617-A, 8618-A	Model 8616-A	8611-A, 8612-A 8614-A, 8615-A	Models 8610-A, 8613-A
Single	4-7/16 113 mm	—	4-1/2 114 mm	—
Double	—	5-7/32 132 mm	—	5-9/32 134 mm

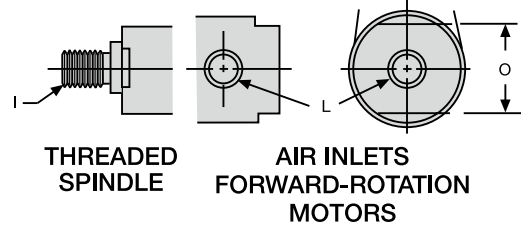

Scale	B	C	D	E	F-Keyed Spindle	F-Th'd. Spindle	G	H	I	L	O
Inches	1-1/16	.936 .937	.580 .590	.374 .375	.644 .691	.581 .628	.0938 .0948	.228 .238	3/8"-24 UNF-2A	1/8 NPTF	7/8
mm	27	23.77 23.80	14.73 14.99	9.50 9.53	16.36 17.55	14.76 15.95	2.38 2.41	5.79 6.05	Th'd.	Air Inlet	22

Scale	P-Keyed Spindle	P-Th'd Spindle	R	S		T	U	V	W	X
				Reversible Direction	Single Direction					
Inches	.149 .186	.024 .061	1-1/8	3-7/16	4-7/16	2-1/32	3/4	1-1/8	1	2-3/16
mm	3.78 4.72	.61 1.55	28	87 mm	113 mm	51	19	28	25	55

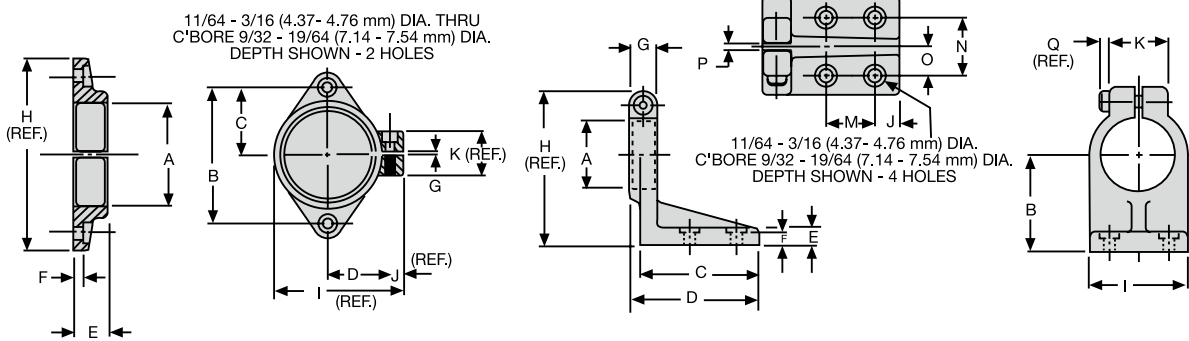

Scale	A	B	C	D	E	F
Inches	.937 .938	1.745 1.755	.870 .880	.677 .697	.365 .385	.177 .197
mm	23.80 23.83	44.32 44.58	22.10 22.35	17.20 17.45	9.27 9.78	4.50 5.00

Scale	A	B	C	D	E	F	G	H
Inches	.937 .938	1.249 1.251	1.609 1.640	1.734 1.765	.240 .260	.177 .197	.182 .192	2-7/32
mm	23.80 23.83	31.72 31.78	40.87 41.66	44.04 44.83	6.10 6.60	4.50 5.00	4.62 4.88	56.36

Scale	G	H	I	J	K
Inches	1/64 3/64	2-1/8	1-1/2	3/16	3/4
mm	0.40 1.19	53.98	38.10	4.76	19.05

Scale	I	J	K	M	N	O	P	Q
Inches	1.234 1.265	.296 .328	.734 .765	.620 .630	.745 .755	.370 .380	.046 .078	1/8
mm	31.34 32.13	7.52 8.33	18.64 19.43	15.75 16.00	18.92 19.18	9.40 9.65	1.17 1.98	3.18



## Series M002 Multi-Vane Air Motors Specifications

Model	Max. Power		Speed at Max. Power	Free Speed ▲	Starting Torque		Stall Torque		Air Consumption at Max. Power		Weight	
	hp	kw	rpm	rpm	lb.-ft.	Nm	lb.-ft.	Nm	scfm	m <sup>3</sup> /m	lb.	kg
<b>Non-Reversible</b> Direction of rotation is counterclockwise when facing the shaft.												
M002RHR000AR3	0.25	0.19	12,250	26,000	0.15	0.20	0.20	0.27	12.0	0.34	1	0.46
M002RHR004AR3	0.22	0.16	3250	6920	0.45	0.61	0.61	0.83	11.9	0.34	1	0.46
M002RHR006AR3	0.22	0.16	2060	4385	0.72	0.98	0.96	1.30	11.9	0.34	1½	0.49
M002RHR008AR3	0.22	0.16	1520	3240	0.98	1.33	1.31	1.78	11.9	0.34	1	0.46
M002RHR013AR3	0.19	0.14	880	1840	1.36	2.50	1.82	2.47	11.8	0.33	1½	0.50
M002RHR021AR3	0.19	0.14	555	1165	2.16	2.93	2.88	3.90	11.8	0.33	1½	0.50
M002RHR028AR3	0.19	0.14	410	860	2.92	3.96	3.90	5.29	11.8	0.33	1½	0.50
M002RHR044AR3	0.19	0.14	262	545	4.61	6.25	6.15	8.34	11.8	0.33	1½	0.50
M002RHR101AR3	0.16	0.12	112	228	*8.32	*11.2	*11.1	*15.0	11.7	0.33	1¾	0.54
M002RHR159AR3	0.16	0.12	71	145	*13.1	*17.7	*17.5	*23.7	11.7	0.33	1¾	0.54
<b>Reversible</b>												
M002RVR000AR3	0.20	0.15	11,500	23,000	0.13	0.18	0.18	0.24	9.8	0.28	1	0.46
M002RVR004AR3	0.17	0.13	3045	6090	0.40	0.54	0.54	0.73	9.7	0.27	1	0.46
M002RVR006AR3	0.17	0.13	1930	3860	0.64	0.87	0.86	1.17	9.7	0.27	1½	0.49
M002RVR008AR3	0.17	0.13	1425	2850	0.87	1.18	1.16	1.57	9.7	0.27	1	0.46
M002RVR013AR3	0.14	0.10	820	1645	1.17	1.58	1.56	2.11	9.6	0.27	1½	0.50
M002RVR021AR3	0.14	0.10	520	1045	1.85	2.51	2.47	3.35	9.6	0.27	1½	0.50
M002RVR028AR3	0.14	0.10	385	770	2.50	3.39	3.34	4.53	9.6	0.27	1½	0.50
M002RVR044AR3	0.14	0.10	240	485	3.96	5.37	5.28	7.16	9.6	0.27	1½	0.50
M002RVR101AR3	0.11	0.08	104	209	*6.78	*9.19	*9.05	*12.2	9.5	0.27	1¾	0.54
M002RVR159AR3	0.11	0.08	66	132	*10.7	*14.5	*14.2	*19.3	9.5	0.27	1¾	0.54

▲ ALL models must be operated with sufficient load to prevent speed from exceeding maximum allowable speed shown on performance curve.

\* Applications with these models must be limited to 12 lb.-ft. (16.3 Nm) torque.  
Performance figures are at 90 psig (620 kPa) air pressure.

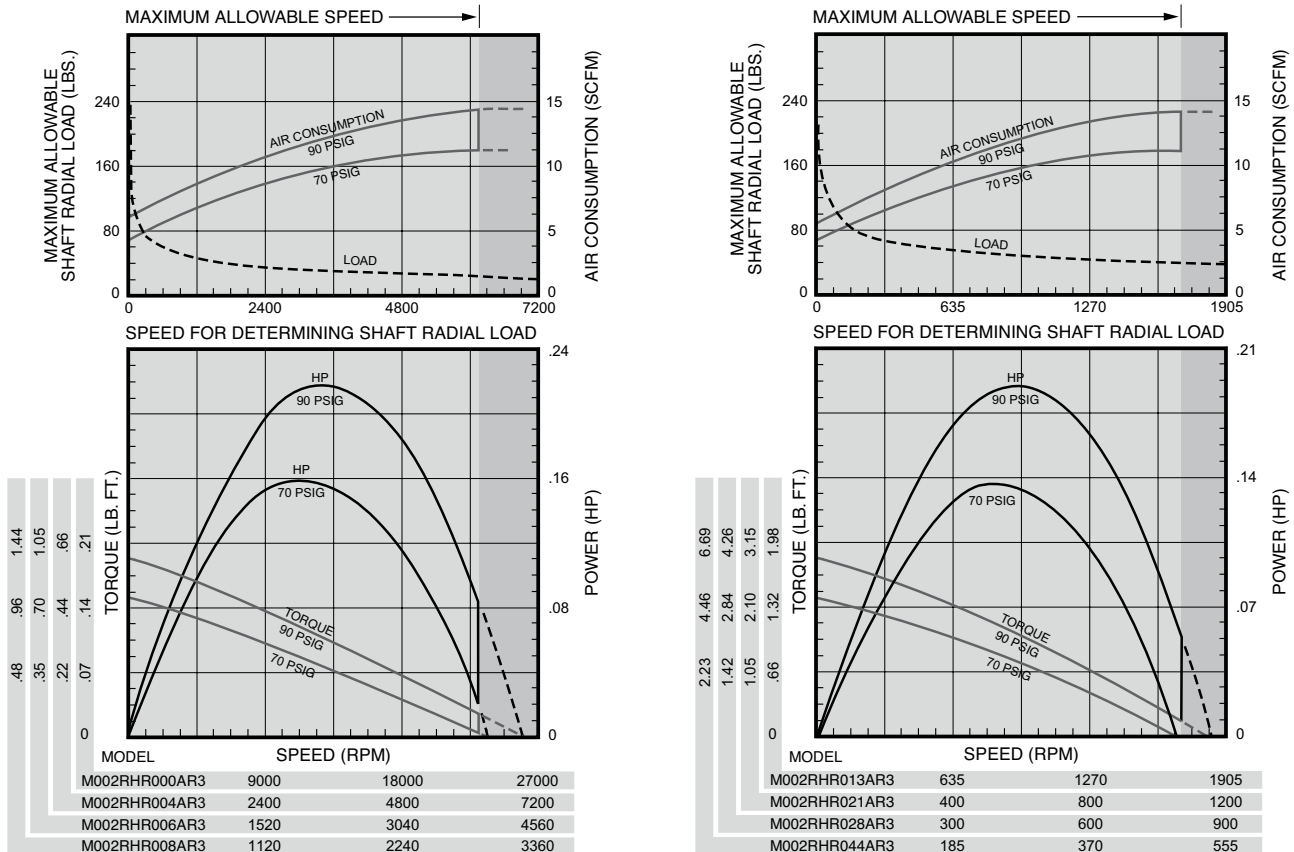

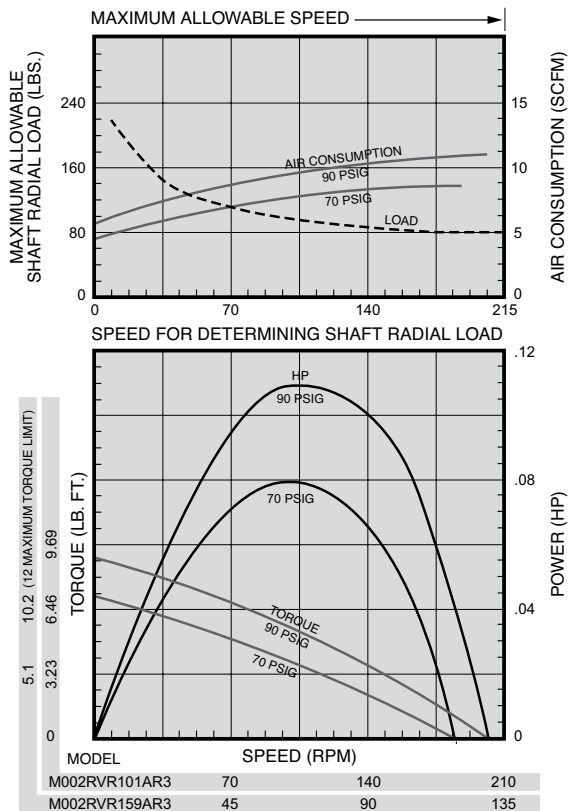
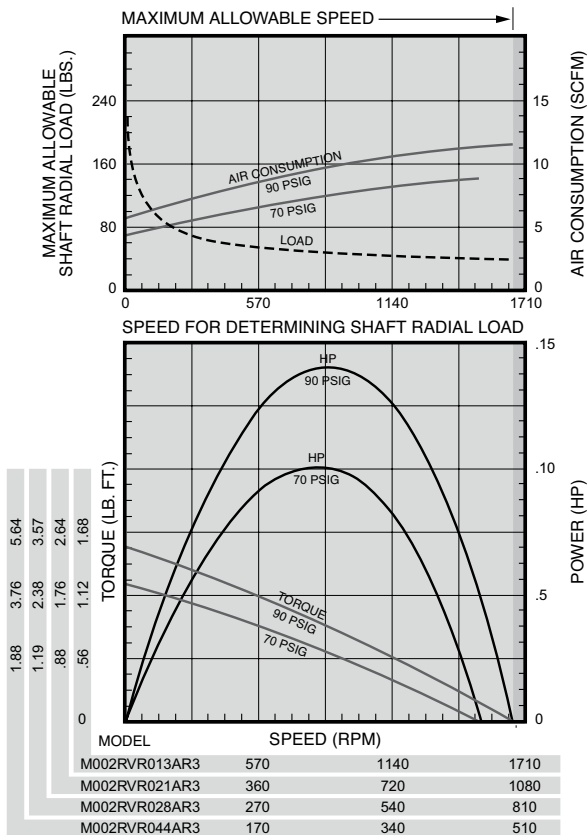
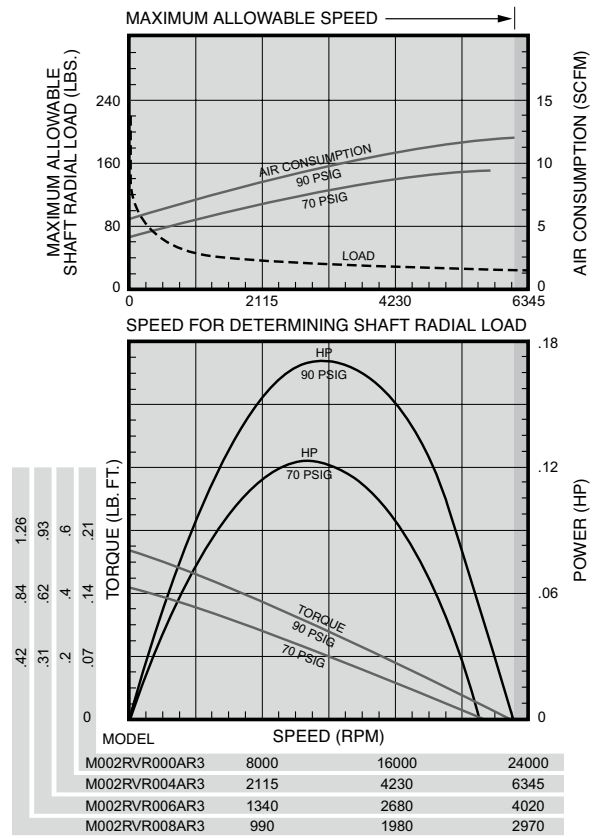
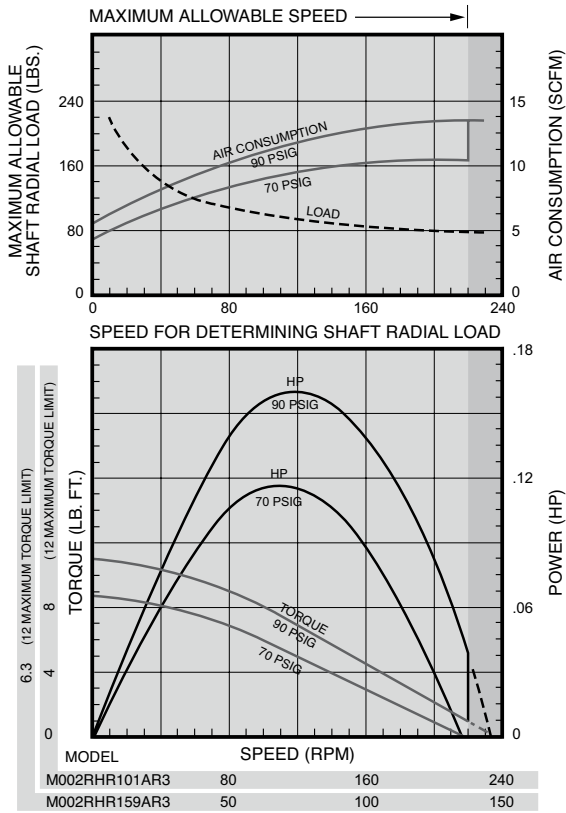

## Series M002 Multi-Vane Air Motors

### Dimensions

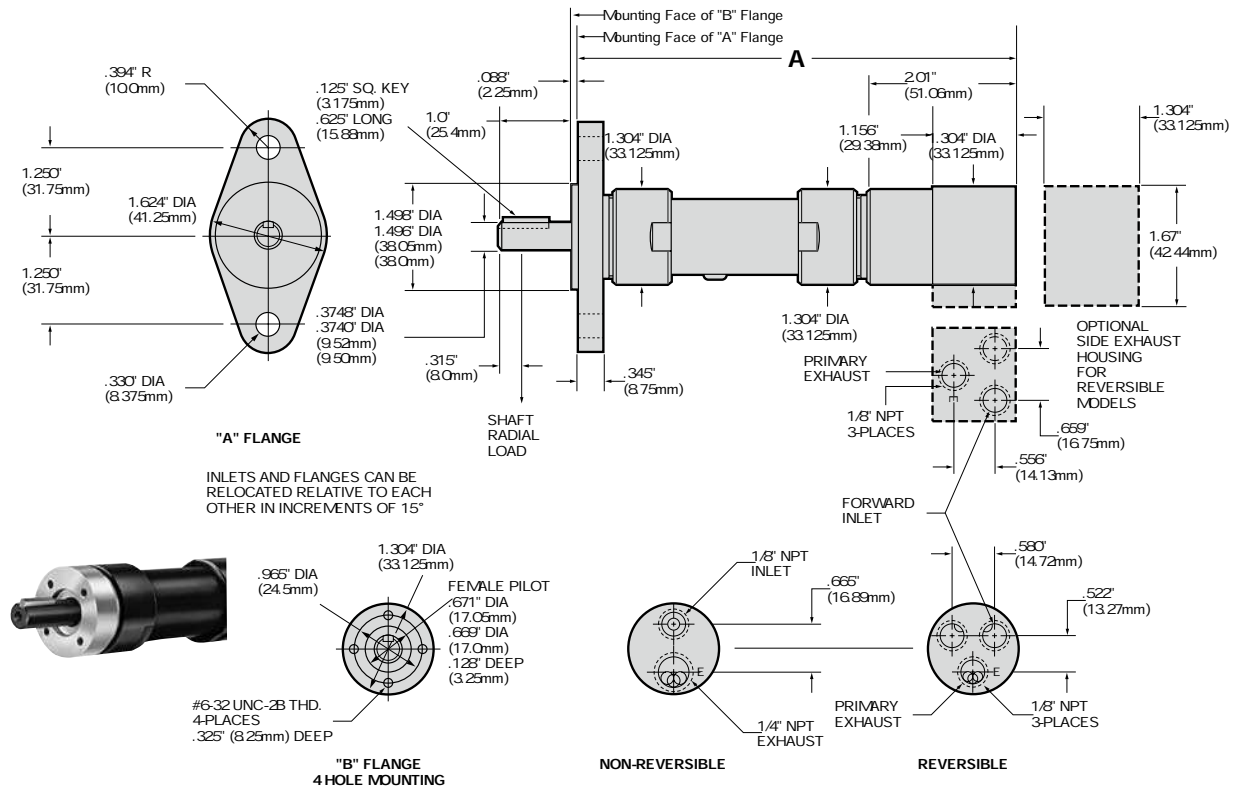

### Series M002 Model Number Symbolization

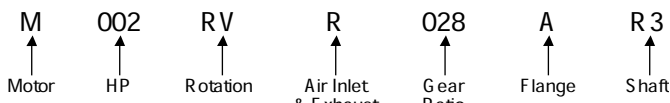

HP = Approximate horsepower range (.11 to .25)

Rotation = RV Reversible

RH Non-Reversible, Right Hand from Rear of Motor (CCW facing shaft)

LH Non-Reversible, Left Hand from Rear of Motor (CW facing shaft)

Air Inlet & Exhaust = R Rear, S Side (Side Inlet and Exhaust available on Reversible Models only)

Gear Ratio = 028 is 1 to 28, 044 is 1 to 44, etc.

Flange = A 2 Hole Flange, B 4 Hole Face Mounting

Shaft = R3 3/8" Round Keyed

T3 3/8"-24 UNF-2A Threaded  
Threaded Shaft Extension is 1" (25.4 mm) with Threaded Length from Shaft End of .87" (22 mm)  
Threaded Shaft Pilot at End is .315" (8 mm) Dia. Max. by .374" (9.5 mm) Long

S3 3/8" Square Drive  
Square Shaft Extension is 1.791" (45.5 mm)

### Dimensions

Gear Ratios (Refer to Model No.)	A	
	in.	mm
000, 004, 008	4.989	126.73
006, 013, 021, 028, 044	5.510	139.93
101, 159	6.020	152.91

### Equipment Options

Furnished with Cataloged Models	Standard Options	Extra Options
2 Hole Flange Mounting	4 Hole Face Mounting	R1440-212-1 3/8" Square Drive Adapter, 1" long with 3/8"-24 Female threads for use with Threaded Shaft.
3/8" Round Keyed Shaft	3/8"-24 Threaded Shaft	Required for 3/8" Adapter (2) 4UA9-561 set screws (1) 8U-722 Bail
	Side Inlet and Exhaust Housing (for Reversible Models only)	

Note: On all Series M002, M004, and M007 Air Motors, performance is the same for both directions of rotation. On Non-Reversible models, direction of rotation may be easily changed without the need of additional parts by inverting cylinder.

## 000-Series Power Motors Specifications

MODEL	SPINDLE	R.P.M.		TORQUE				AIR CONSUMPTION		SOUND LEVEL @FREE SPEED dB(A)	WEIGHT		GEAR REDUCTION
		FREE SPEED	LOAD @MAX. H.P.	STALL lb. ft. Nm	OUTPUT @MAX. H.P. lb. ft. Nm	SCFM	L/s	lbs.	kg.				
<b>NON-REVERSIBLE - .25 H.P.</b>													
7538-B	3/8" Keyed	550	325	8.2	11.1	4.0	5.4	18.1	8.5	75	1.82	.82	Double
7539-B	3/8" Keyed	900	550	5.0	6.7	2.4	3.2	18.1	8.5	75	1.82	.82	Double
7540-B	3/8" Keyed	2,700	1,600	1.75	2.3	.82	1.1	18.1	8.5	75	1.52	.68	Single
7541-B	3/8" Keyed	4,500	2,700	1.05	1.4	.49	.66	18.1	8.5	75	1.52	.68	Single
7542-C	3/8" Keyed	20,000	12,000	.22	.3	.11	.14	18.1	8.5	75	1.52	.68	Single
7533-B	3/8"-24 Th'd.	550	325	8.2	11.1	4.0	5.4	18.1	8.5	75	1.82	.82	Double
7534-B	3/8"-24 Th'd.	900	550	5.0	6.7	2.4	3.2	18.1	8.5	75	1.82	.82	Double
7535-C	3/8"-24 Th'd.	2,700	1,600	1.75	2.3	.82	1.1	18.1	8.5	75	1.52	.68	Single
7536-B	3/8"-24 Th'd.	4,500	2,700	1.05	1.4	.49	.66	18.1	8.5	75	1.52	.68	Single
7537-C	3/8"-24 Th'd.	20,000	12,000	.22	.3	.11	.14	18.1	8.5	75	1.52	.68	Single
<b>REVERSIBLE - .25 H.P.</b>													
7543-B	3/8" Keyed	550	300	7.80	10.6	4.37	5.9	20.0	9.4	75*	1.82	.82	Double
7544-B	3/8" Keyed	900	550	4.75	6.4	2.62	3.5	20.0	9.4	75*	1.82	.82	Double
7545-B	3/8" Keyed	2,700	1,500	1.60	2.2	.87	1.1	20.0	9.4	75*	1.52	.68	Single
7546-B	3/8" Keyed	4,500	2,400	.98	1.3	.55	.7	20.0	9.4	75*	1.52	.68	Single
7547-C	3/8" Keyed	20,000	11,000	.22	.3	.12	.16	20.0	9.4	75*	1.52	.68	Single

\*Requires installation for reversible motors - shown on page 85.

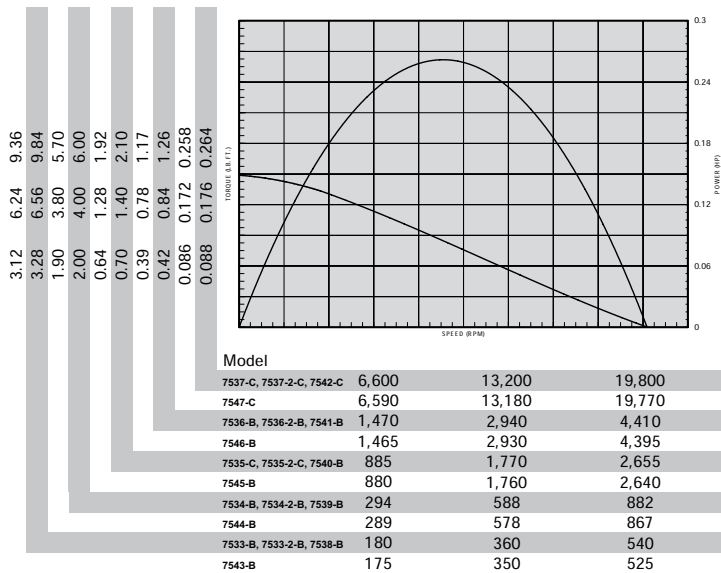

### Standard Equipment

Steel motor housing, flush-type grease fittings at rotation points for gear and bearing lubrication, exhaust manifold and muffler.



### Equipment Options

- 37898 Flange Bracket
- 37899 Foot Bracket



37898



37899

### Options for Motors with Thread Spindles

- 30384-5 3/8" (9.5 mm) Male Square-Drive Adapter
- 30384-9 1/2" (12.7 mm) Male Square-Drive Adapter
- 30712 1/4" (6.4 mm) Female Hex Ball-Lock Adapter for screwdriver bits
- 47340 1/4" (6.4 mm) Capacity Drill Chuck
- 42420 3/8" (9.5 mm) Arbor for rubber friction drive wheels up to 1" (25.4 mm) wide



## 000-Series Power Motors and Mounting Accessory Dimensions

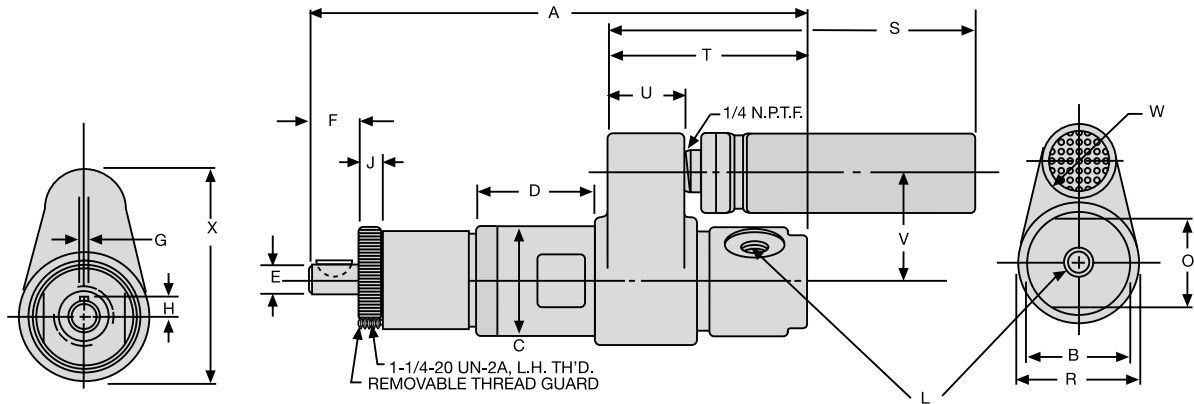

**FORWARD ROTATION, DOUBLE REDUCTION SHOWN**

Gear Reduction	DIMENSION A
Single	4-15/16 125 mm
Double	6 152 mm

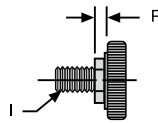

**THREADED SPINDLE**

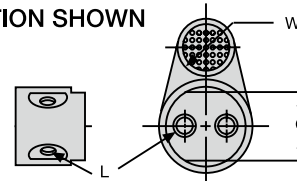

**AIR INLETS, REVERSIBLE MOTORS**

Scale	B	C	D	E	F	G	H	I	J	L
Inches	1-3/8	1.373	1-9/32	.3748	.592	.0938	.228	3/8"-24	.251	1/8" NPTF Air Inlet
mm	35	34.87	32	.3751	.643	.0948	.238	UNF-3A Thread	.276	
		34.93		9.52	15.04	2.38	5.79		6.38	
				9.53	16.33	2.41	6.05		7.01	

Scale	O	P	R	S	T	U	V	W	X
Inches	1-1/8	.086	1-5/8	4-9/16	2-15/32	31/32	1-3/8	1	2-11/16
mm	28	2.18	41	116	63	25	35	25	68
	Rev. 1-3/16	.139							
	Rev. 30	3.53							

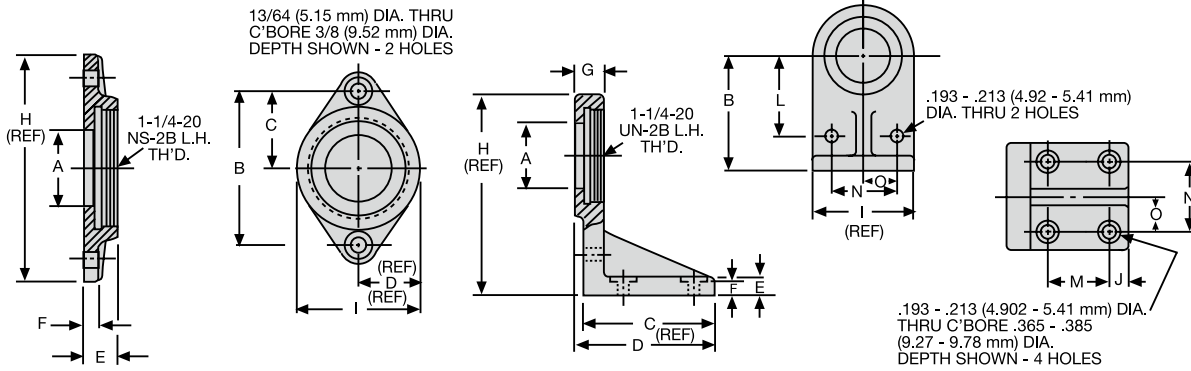

**37898 FLANGE MOUNTING BRACKET**

Scale	A	B	C	D
Inches	.865	2.042	1.021	13/16
mm	.885	2.082	1.041	
	21.97	51.89	25.93	
	22.48	52.89	26.44	20.64

Scale	E	F	H	I
Inches	.380	.177	2-9/16	1-5/8
mm	.400	.197		
	9.65	4.50	65.09	41.28
	10.16	5.00		

**37899 FOOT MOUNTING BRACKET**

Scale	A	B	C	D	E	F	G
Inches	.865	1.865	1.740	1-7/8	7/32	.177	.380
mm	.885	1.885	1.760		9/32	.197	.400
	21.97	47.37	44.20	47.63	5.56	4.50	9.65
	22.48	47.88	44.70		7.14	5.00	10.16

Scale	H	I	J	L	M	N	O
Inches	2-11/16	1-5/8	.271	1.302	.927	1.052	.521
mm			.291	1.322	.947	1.072	.541
	68.26	41.27	6.88	33.07	23.55	26.27	13.23
		41.28	7.39	33.56	24.05	27.23	13.74



## Series M004 Multi-Vane Air Motors Specifications

Model	Max. Power		Speed at Max. Power	Free Speed ▲	Starting Torque		Stall Torque		Air Consumption at Max. Power		Weight	
	hp	kw	rpm	rpm	lb.-ft.	Nm	lb.-ft.	Nm	scfm	m³/m	lb.	kg
<b>Non-Reversible</b> Direction of rotation is counterclockwise when facing the shaft.												
M004RHR000AR3	0.50	0.37	10,000	18,000	0.40	0.54	0.53	0.72	20.0	0.57	2 <sup>1</sup> / <sub>16</sub>	0.95
M004RHR004AR3	0.47	0.35	2470	4450	1.46	1.98	1.94	2.63	19.5	0.55	2 <sup>3</sup> / <sub>16</sub>	1.00
M004RHR006AR3	0.47	0.35	1490	2680	2.42	3.28	3.22	4.37	19.5	0.55	2 <sup>3</sup> / <sub>16</sub>	1.00
M004RHR011AR3	0.44	0.33	825	1490	3.92	5.32	5.22	7.08	19.0	0.54	2 <sup>3</sup> / <sub>16</sub>	1.09
M004RHR015AR3	0.44	0.33	610	1095	5.32	7.21	7.10	9.63	19.0	0.54	2 <sup>3</sup> / <sub>16</sub>	1.09
M004RHR023AR3	0.44	0.33	395	715	8.10	11.0	10.8	14.6	19.0	0.54	2 <sup>3</sup> / <sub>16</sub>	1.09
M004RHR033AR3	0.44	0.33	280	505	11.5	15.6	15.4	20.8	19.0	0.54	2 <sup>3</sup> / <sub>16</sub>	1.09
M004RHR050AR3	0.41	0.31	175	315	*16.5	*22.4	*22.1	*30.0	18.5	0.52	2 <sup>1</sup> / <sub>16</sub>	1.22
M004RHR083AR3	0.41	0.31	106	190	*27.5	*37.3	*36.7	*49.7	18.5	0.52	2 <sup>1</sup> / <sub>16</sub>	1.22
M004RHR167AR3	0.41	0.31	53	95	*55.0	*74.5	*73.3	*99.4	18.5	0.52	2 <sup>1</sup> / <sub>16</sub>	1.22
<b>Reversible</b>												
M004RVR000AR3	0.40	0.30	8000	16,000	0.32	0.43	0.42	0.57	19.0	0.54	2 <sup>1</sup> / <sub>16</sub>	0.95
M004RVR004AR3	0.37	0.28	1975	3955	1.13	1.53	1.51	2.05	18.5	0.52	2 <sup>3</sup> / <sub>16</sub>	1.00
M004RVR006AR3	0.37	0.28	1190	2380	1.88	2.55	2.51	3.40	18.5	0.52	2 <sup>3</sup> / <sub>16</sub>	1.00
M004RVR011AR3	0.34	0.25	660	1325	3.00	4.07	4.00	5.42	18.0	0.51	2 <sup>3</sup> / <sub>16</sub>	1.09
M004RVR015AR3	0.34	0.25	485	975	4.07	5.52	5.43	7.36	18.0	0.51	2 <sup>3</sup> / <sub>16</sub>	1.09
M004RVR023AR3	0.34	0.25	315	635	6.23	8.45	8.30	11.2	18.0	0.51	2 <sup>3</sup> / <sub>16</sub>	1.09
M004RVR033AR3	0.34	0.25	225	450	8.85	12.0	11.8	16.0	18.0	0.51	2 <sup>3</sup> / <sub>16</sub>	1.09
M004RVR050AR3	0.31	0.23	140	280	*12.3	*16.7	*16.5	*22.4	17.5	0.50	2 <sup>1</sup> / <sub>16</sub>	1.22
M004RVR083AR3	0.31	0.23	84	169	*20.6	*27.9	*27.5	*37.3	17.5	0.50	2 <sup>1</sup> / <sub>16</sub>	1.22
M004RVR167AR3	0.31	0.23	42	85	*41.3	*56.0	*55.0	*74.5	17.5	0.50	2 <sup>1</sup> / <sub>16</sub>	1.22

▲ ALL models must be operated with sufficient load to prevent speed from exceeding maximum allowable speed shown on performance curve.

\* Applications with these models must be limited to 33 lb.-ft. (44.7 Nm) torque. Performance figures are at 90 psig (620 kPa) air pressure.

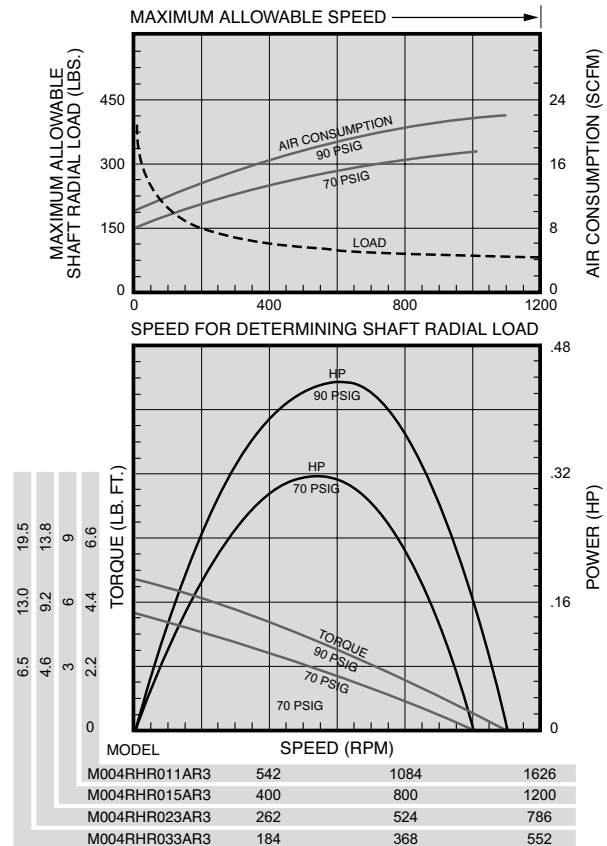
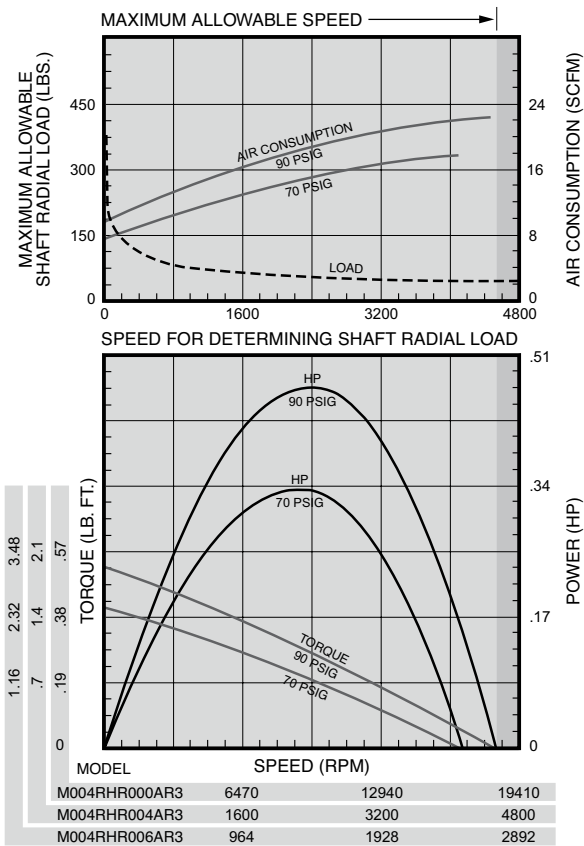

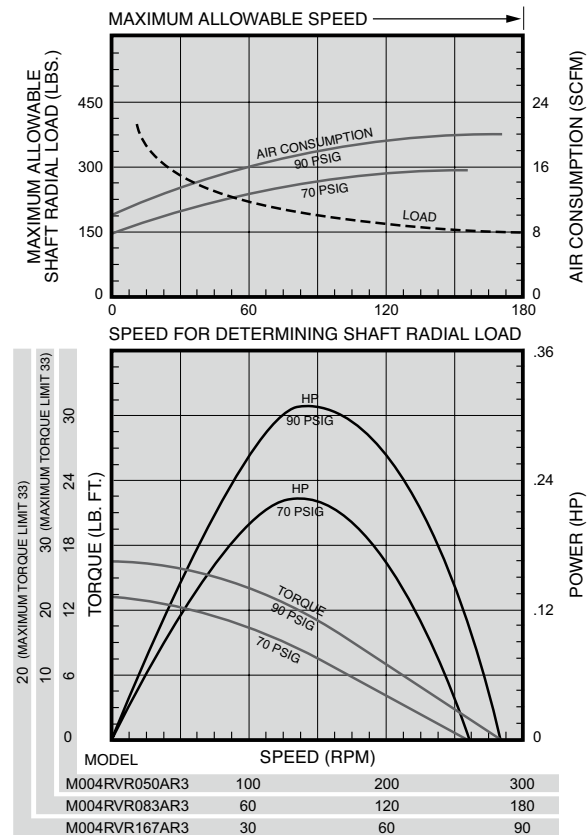
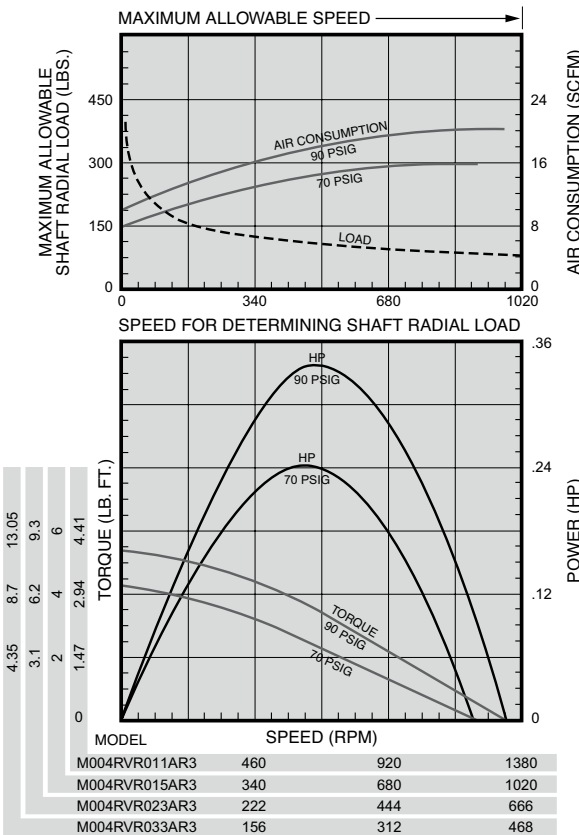
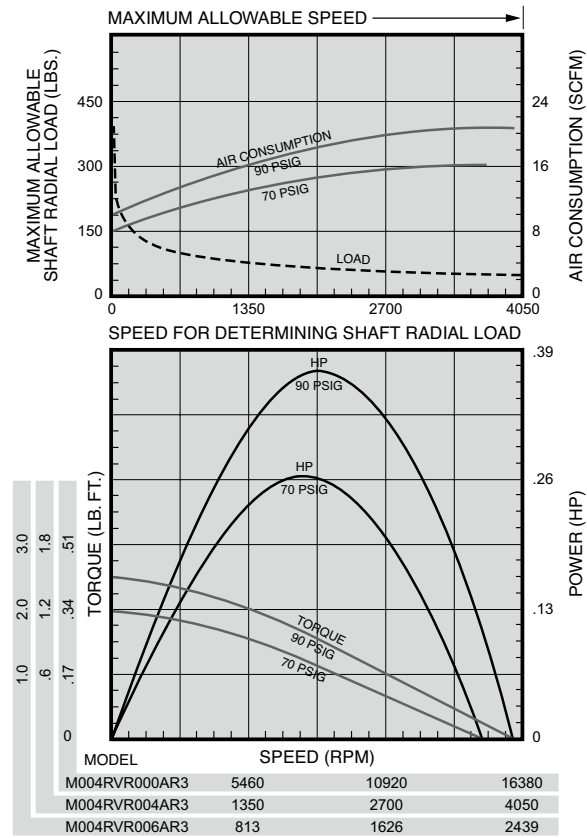
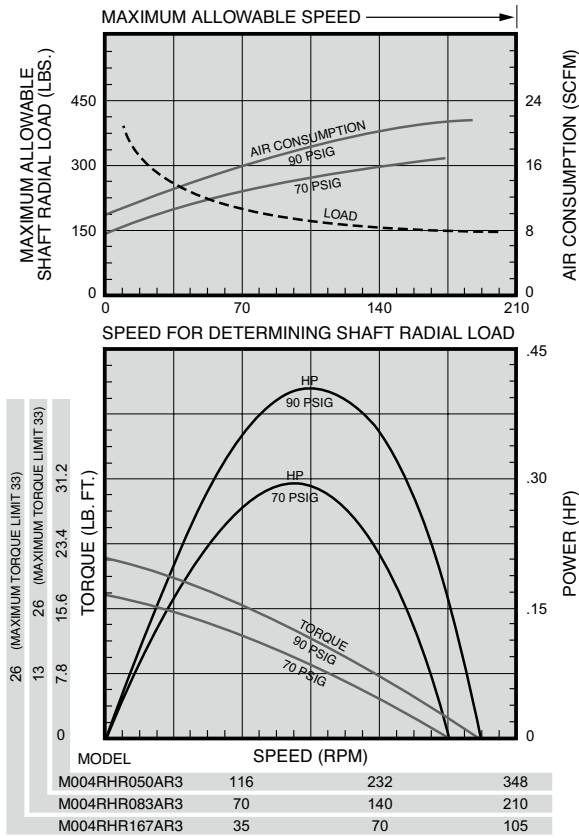

# Series M004 Multi-Vane Air Motors

## Dimensions

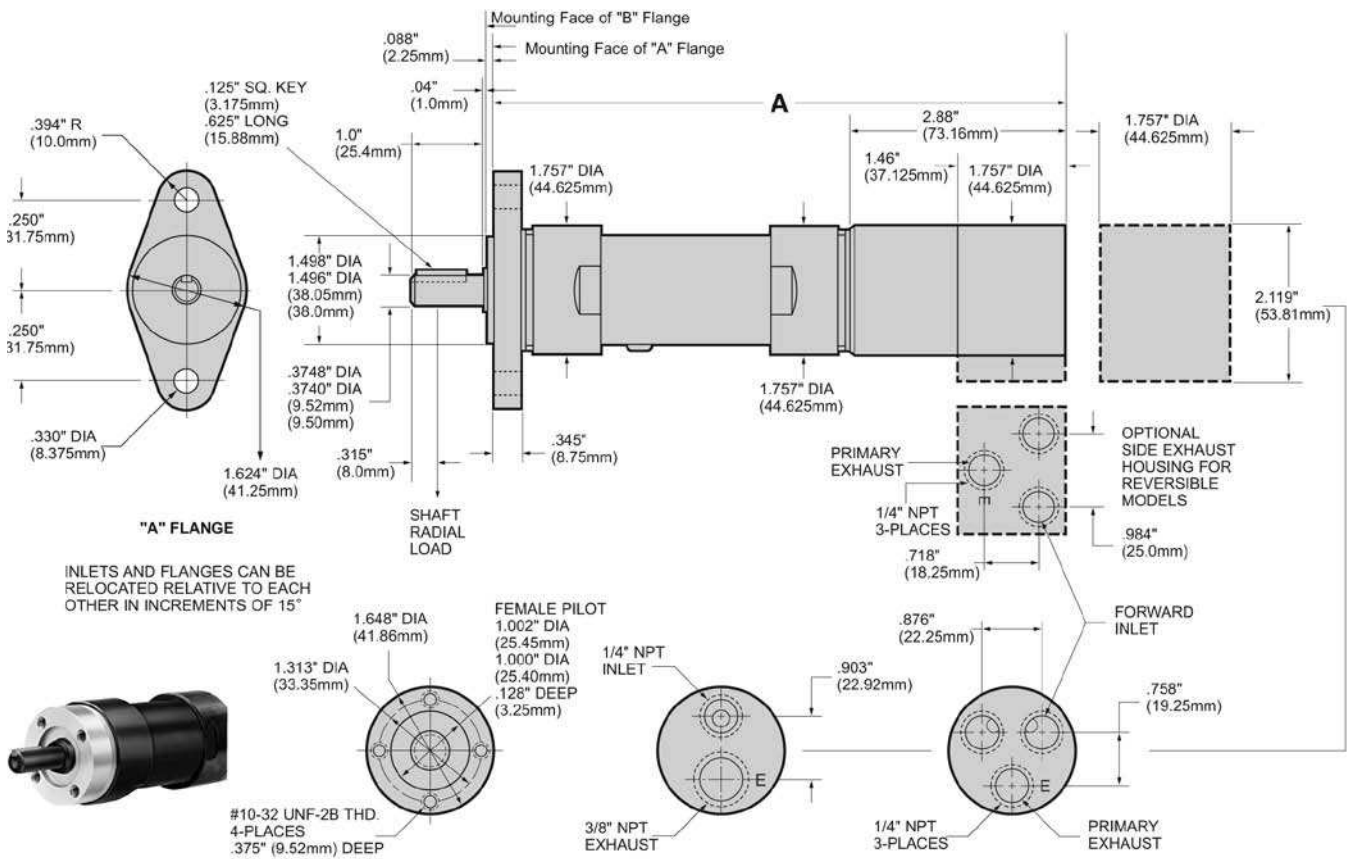

## Series M004 Model Number Symbolization

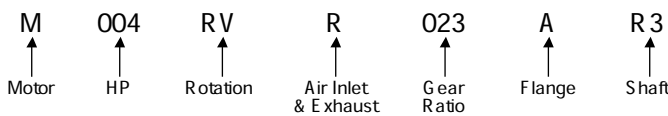

HP = Approximate horsepower range (.31 to .50)

- Rotation = RV Reversible
- RH Non-Reversible, Right Hand from Rear of Motor (CCW facing shaft)
- LH Non-Reversible, Left Hand from Rear of Motor (CW facing shaft)

Air Inlet & Exhaust = R Rear, S Side (Side Inlet and Exhaust available on Reversible Models only)

Gear Ratio = 023 is 1 to 23, 033 is 1 to 33, etc.

Flange = A 2 Hole Flange, B 4 Hole Face Mounting

- Shaft = R3 3/8" Round Keyed
- T3 3/8"-24 UNF-2A Threaded  
Threaded Shaft Extension is .512" (13 mm)  
Full Thread Length is .424" (10.75 mm)
- S3 3/8" Square Drive  
Square Shaft Extension is 1.791" (45.5 mm)

## Dimensions

Gear Ratios (Refer to Model No.)	A	
	in.	mm
000, 004, 006	6.248	158.69
011, 015, 023, 033	6.984	177.38
050, 083, 167	7.745	196.73

## Equipment Options

Furnished with Cataloged Models	Standard Options	Extra Options
2 Hole Flange Mounting	4 Hole Face Mounting	R1440-212-1 3/8" Square Drive Adapter, 1" long with 3/8"-24 Female threads for use with Threaded Shaft.
3/8" Round Keyed Shaft	3/8"-24 Threaded Shaft	
	Side Inlet and Exhaust Housing (for Reversible Models only)	Required for 3/8" Adapter (2) 4UA9-561 set screws

Note: On all Series M002, M004, and M007 Air Motors, performance is the same for both directions of rotation. On Non-Reversible models, direction of rotation may be easily changed without the need of additional parts by inverting cylinder. See Assembly Instruction form number listed in price sheet.





## O-Series Power Motors (with O-Series Gearing) Specifications

MODEL	SPINDLE	R.P.M.		TORQUE		AIR		SOUND LEVEL @FREE SPEED dB(A)	WEIGHT		GEAR REDUCTION
		FREE SPEED	LOAD SPEED @MAX. H.P.	STALL lb. ft. Nm	OUTPUT @MAX. H.P. lb. ft. Nm	CONSUMPTION @FREE SPEED SCFM L/s	lbs.		kg.		
<b>NON-REVERSIBLE - .60 H.P.</b>											
8230-1A	3/8" Keyed	19,000	9,800	.70 .9	.32 .4	41	19.3	80	2.45	1.10	Single
8230-2A	3/8" Keyed	5,700	2,900	2.5 2.9	1.10 1.5	41	19.3	80	2.45	1.10	Single
8230-3A	3/8" Keyed	3,500	1,750	3.50 4.7	1.80 2.4	41	19.3	80	2.45	1.10	Single
8230-4A	3/8" Keyed	2,800	1,400	4.50 6.1	2.20 3.0	41	19.3	80	2.45	1.10	Single
8230-5A	3/8" Keyed	1,650	840	7.50 10.2	3.80 5.1	41	19.3	80	2.98	1.34	Double
8230-6A	3/8" Keyed	1,000	500	12.00 16.3	6.20 8.4	41	19.3	80	2.98	1.34	Double
8230-7A	3/8" Keyed	800	390	14.80 20.0	8.00 10.8	41	19.3	80	2.98	1.34	Double
8230-8A	3/8" Keyed	600	315	19.60 26.5	10.00 13.5	41	19.3	80	2.98	1.34	Double
8230-9A	3/8" Keyed	500	250	24.00 32.5	12.50 16.9	41	19.3	80	2.98	1.34	Double
8229-1A	3/8"-24 Th'd.	19,000	9,800	.70 .9	.32 .4	41	19.3	80	2.45	1.10	Single
8229-2A	3/8"-24 Th'd.	5,700	2,900	2.15 2.9	1.10 1.5	41	19.3	80	2.45	1.10	Single
8229-3A	3/8"-24 Th'd.	3,500	1,750	3.50 4.7	1.80 2.4	41	19.3	80	2.45	1.10	Single
8229-4A	3/8"-24 Th'd.	2,800	1,400	4.50 6.1	2.20 3.0	41	19.3	80	2.45	1.10	Single
8229-5A	3/8"-24 Th'd.	1,650	840	7.50 10.2	3.80 5.1	41	19.3	80	2.98	1.34	Double
8229-6A	3/8"-24 Th'd.	1,000	500	12.00 16.3	6.20 8.4	41	19.3	80	2.98	1.34	Double
8229-7A	3/8"-24 Th'd.	800	390	14.80 20.0	8.00 10.8	41	19.3	80	2.98	1.34	Double
8229-8A	3/8"-24 Th'd.	600	315	19.60 26.5	10.00 13.5	41	19.3	80	2.98	1.34	Double
8229-9A	3/8"-24 Th'd.	500	250	24.00 32.5	12.50 16.9	41	19.3	80	2.98	1.34	Double
<b>REVERSIBLE - .50 H.P.</b>											
8231-1B	3/8" Keyed	18,000	9,200	.52 .7	.28 .4	32	15.1	80*	2.45	1.10	Single
8231-2B	3/8" Keyed	5,300	2,600	1.70 2.3	1.00 1.3	32	15.1	80*	2.45	1.10	Single
8231-3B	3/8" Keyed	3,200	1,550	2.90 3.9	1.70 2.3	32	15.1	80*	2.45	1.10	Single
8231-4B	3/8" Keyed	2,600	1,300	3.50 4.7	2.00 2.7	32	15.1	80*	2.45	1.10	Single
8231-5B	3/8" Keyed	1,500	780	5.90 8.0	3.50 4.7	32	15.1	80*	2.98	1.34	Double
8231-6B	3/8" Keyed	950	480	9.50 12.9	5.50 7.4	32	15.1	80*	2.98	1.34	Double
8231-7B	3/8" Keyed	750	380	11.80 16.0	7.00 9.5	32	15.1	80*	2.98	1.34	Double
8231-8B	3/8" Keyed	575	290	15.50 21.0	9.00 12.2	32	15.1	80*	2.98	1.34	Double
8231-9B	3/8" Keyed	475	240	19.40 26.2	11.00 14.9	32	15.1	80*	2.98	1.34	Double

\*R requires installation for reversible motors - shown on page 88.

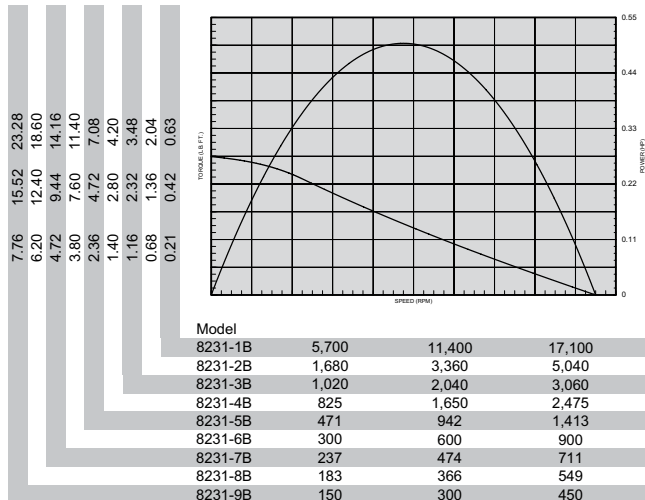
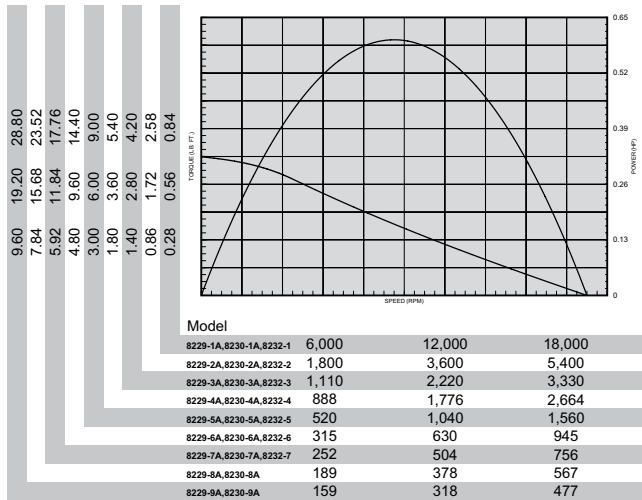

### Equipment Options

- 37896 Flange Bracket
- 37897 Foot Bracket

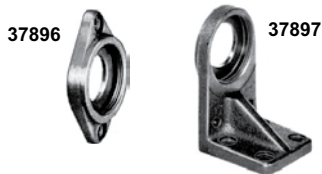

### Standard Equipment

Steel motor housing, flush-type grease fittings at rotation points for gear and bearing lubrication, exhaust manifold rotatable within 360°, and muffler.

### Options for Motors with Thread Spindles

- 30384-5 3/8" (9.5 mm) Male Square-Drive Adapter
- 30384-9 1/2" (12.7 mm) Male Square-Drive Adapter
- 30712 1/4" (6.4 mm) Female Hex Ball-Lock Adapter for screwdriver bits
- 47341 5/16" (7.9 mm) Capacity Drill Chuck
- 47420 3/8" (9.5 mm) Arbor for rubber friction drive wheels up to 1" (25.4 mm) wide

## O-Series Power Motors and Mounting Accessory Dimensions

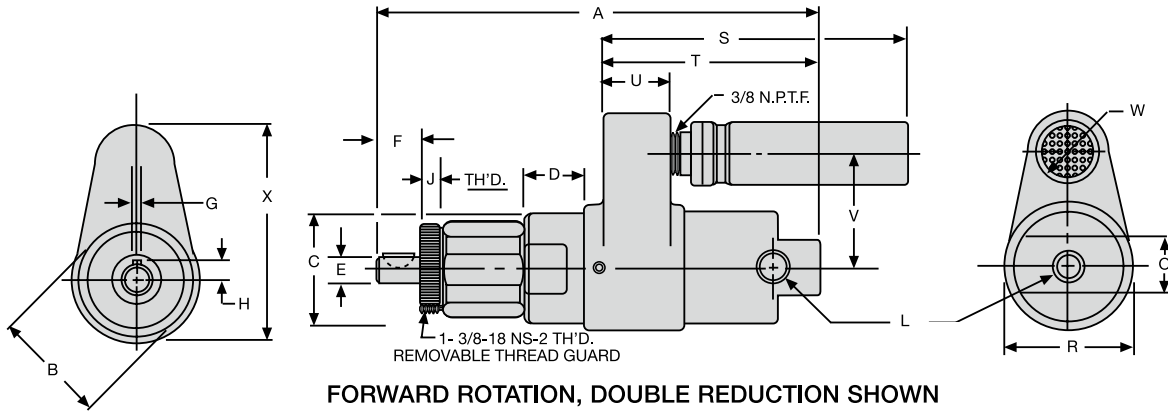

DIMENSION A		
Gear Reduction	Series 8231	Series 8229-8230
Single	5-5/8 143 mm	5-3/4 146 mm
Double	6-15/16 176 mm	7-1/16 179 mm

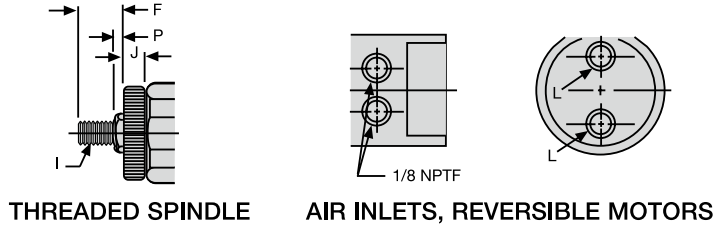

Scale	B	C	D	E	F	G	H	I	J	L
Inches	1-3/4	1.730 1.740	.960 .980	.3748 .3751	.688 .740	.0938 .0948	.228 .238	3/8"-24 UNF-3A Thread	.270 .292	1/4" Female NPTF Air Inlet
mm	44	43.94 44.20	24.38 24.89	9.52 9.53	17.48 18.80	2.38 2.41	5.79 6.05		6.86 7.42	

Scale	O	P	R	S	T - Forw.	T	U	V	W	X
Inches	7/8	.163-.203	2	4-7/8	3-13/32	3-9/32	1-1/16	1-13/16	1	3-7/16
mm	22	4.14 5.16	51	124	86	83	27	46	25	87

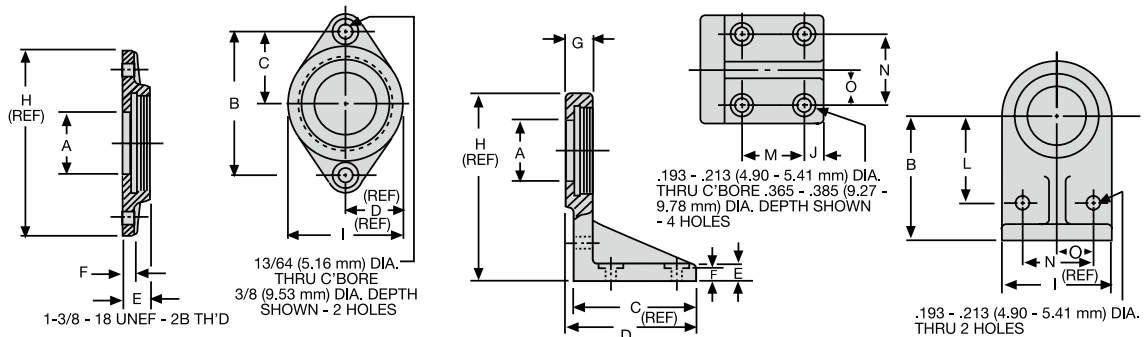

### 37896 FLANGE MOUNTING BRACKET

Scale	A	B	C	D
Inches	.865 .885	2.042 2.082	1.021 1.041	13/16
mm	21.97 22.48	51.89 52.88	25.93 26.44	20.64

Scale	E	F	H	I
Inches	.380 .400	.177 .197	2-9/16	1-5/8
mm	9.65 10.16	4.50 5.00	65.09	41.28

### 37897 FOOT MOUNTING BRACKET

Scale	A	B	C	D	E	F	G
Inches	.865 .885	1.865 1.885	1.740 1.760	1-7/8	7/32 9/32	.177 .197	.380 .400
mm	21.97 22.48	47.37 47.88	44.20 44.70	47.63	5.56 7.14	4.50 5.00	9.65 10.16

Scale	H	I	J	L	M	N	O
Inches	2-11/16	1-5/8	.271 .291	1.302 1.322	.927 .947	1.052 1.072	.521 .541
mm	68.26	41.27	6.88 7.39	33.07 33.58	23.55 24.05	26.27 27.23	13.23 13.74

## O-Series Power Motors (with 2200 Series Gearing) Specifications

MODEL	SPINDLE	R.P.M.		TORQUE			AIR CONSUMPTION			SOUND LEVEL @FREE SPEED dB(A)	WEIGHT		GEAR REDUCTION
		FREE SPEED	LOAD SPEED @MAX H P	STALL lb ft	Nm	OUTPUT @MAX. H.P. lb. ft. Nm	@FREE SPEED SCFM	L/s	lbs		kg		
<b>NON-REVERSIBLE - .60 H.P.</b>													
8226-6A	1/2" Keyed	700	350	17.20	23.3	9.00	12.2	40.5	19.1	80	4.25	1.91	Double
8226-7A	1/2" Keyed	450	225	26.00	35.2	13.70	18.6	40.5	19.1	80	4.25	1.91	Double
8226-8A	1/2" Keyed	375	185	32.00	43.4	17.00	23.0	40.5	19.1	80	4.25	1.91	Double
8226-10A	1/2" Keyed	170	87	**60.00	88.1	36.00	48.8	40.5	19.1	80	5.56	2.50	Triple
8226-11A**	1/2" Keyed	110	57	**60.00	134.1	55.00	74.5	40.5	19.1	80	5.56	2.50	Triple
8226-12A**	1/2" Keyed	90	45	**60.00	165.3	**60.00	94.8	40.5	19.1	80	5.56	2.50	Triple
8226-13A**	1/2" Keyed	60	30	**60.00	249.3	**60.00	139.6	40.5	19.1	80	5.56	2.50	Triple
8226-14A**	1/2" Keyed	50	25	**60.00	306.2	**60.00	169.4	40.5	19.1	80	5.56	2.50	Triple
<b>REVERSIBLE - .50 H.P.</b>													
8228-2B	1/2" Keyed	3,200	1,550	2.90	3.9	1.70	2.3	30	14	80*	4.25	1.91	Double
8228-3B	1/2" Keyed	2,600	1,300	3.50	4.7	2.00	2.7	30	14	80*	4.25	1.91	Double
8228-5B	1/2" Keyed	800	420	11.20	15.2	6.30	8.5	30	14	80*	4.25	1.91	Double
8228-6B	1/2" Keyed	650	330	13.80	18.7	8.00	10.8	30	14	80*	4.25	1.91	Double
8228-7B	1/2" Keyed	425	220	20.00	27.1	12.00	16.3	30	14	80*	4.25	1.91	Double
8228-8B	1/2" Keyed	350	185	25.00	33.9	14.00	19.0	30	14	80*	4.25	1.91	Double
8228-9B	1/2" Keyed	200	105	45.00	61.0	25.00	33.9	30	14	80*	5.56	2.50	Triple
8228-10B	1/2" Keyed	160	80	55.00	74.5	33.00	44.7	30	14	80*	5.56	2.50	Triple
8228-11B**	1/2" Keyed	100	54	**60.00	81.3	48.00	65.0	30	14	80*	5.56	2.50	Triple
8228-12B**	1/2" Keyed	85	43	**60.00	81.3	**60.00	81.3	30	14	80*	5.56	2.50	Triple
8228-13B**	1/2" Keyed	50	28	**60.00	81.3	**60.00	81.3	30	14	80*	5.56	2.50	Triple
8228-14B**	1/2" Keyed	40	22	**60.00	81.3	**60.00	81.3	30	14	80*	5.56	2.50	Triple

\*R requires installation for reversible motors - shown on page 88.

\*\*NOTE: Maximum torque recommended for planetary gear system on these models requires shear key with 60 ft./lbs. shear strength.

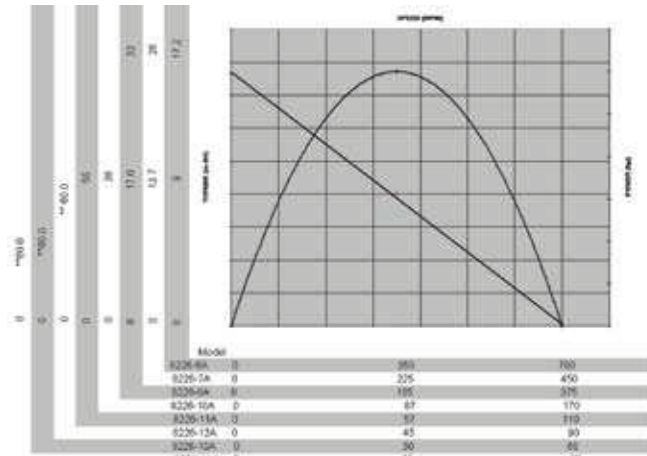

\*\*Note: Maximum torque recommended for planetary gear system on these models is 60 ft./lbs.

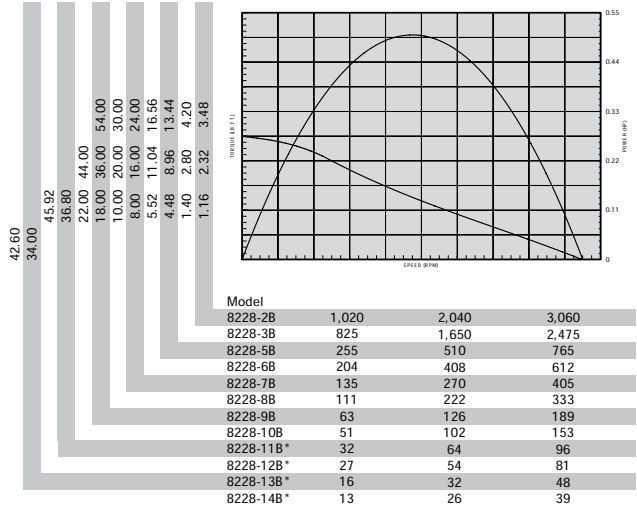

\*\*NOTE: Maximum torque recommended for planetary gear system on these models requires shear key with 60 ft./lbs. shear strength.

### Standard Equipment

Steel motor housing, flush-type grease fittings at rotation points for gear and bearing lubrication, exhaust manifold rotatable within 360°, and muffler.



### Equipment Options

37895-1 Flange Bracket  
Provision for flange mounting is standard on all models.



37895-1

### No-Cost Options Furnished When Specified on Original Order

1/2"-20 Male Threaded Spindle on forward-rotation models

## 0/2200-Series Power Motors and Mounting Accessory Dimensions

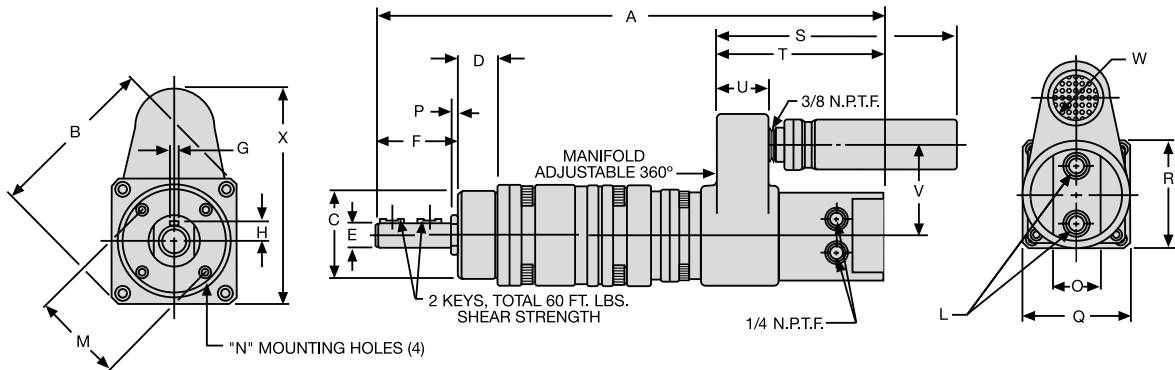

REVERSIBLE ROTATION, TRIPLE REDUCTION SHOWN

DIMENSION A		
Gear Reduction	Series 8226	Series 8228
Double	8-11/16 221 mm	8-9/16 217 mm
Triple	10-1/2 267 mm	10-3/8 264 mm

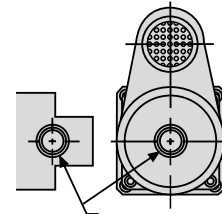

AIR INLETS, SINGLE-DIRECTION MOTORS

Scale	B	C	D	E	F	G	H	L	M	N
Inches	2-11/16	1.7490 1.7495	.774 .818	.4990 .4995	1.604 1.655	.125 .126	.299 .309	1/4 NPTF	1.432 1.442	10-24 UNC-2B
mm	68	44.42 44.44	19.66 20.78	12.67 12.69	40.74 42.04	3.18 3.20	7.72 7.98	Air Inlet	36.37 36.63	Thread

Scale	O	P	Q	R	S	T - Forward Rotation	T Reversible	U	V	W	X
Inches	7/8	.098 .164	2	2	4-7/8	3-13/32	3-9/32	1-1/16	1-13/16	1	3-7/16
mm	22	2.49 4.17	51	51	124	86	83	27	46	25	87

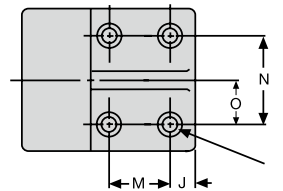
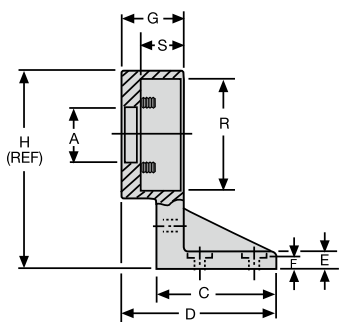

.193 - .213 (4.90 - 5.41 mm) DIA. THRU C'BORE .365 - .385 (9.27 - 9.78 mm) DIA. DEPTH SHOWN - 4 HOLES

.193 - .213 (4.90 - 5.41 mm) DIA. THRU C'BORE .365 - .385 (9.27 - 9.78 mm) DIA. X .193 - .213 DEEP (FOR Y154-51 SCREWS)

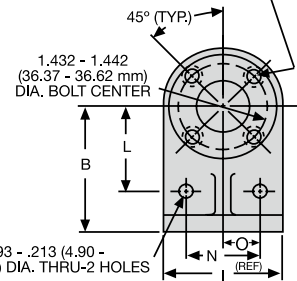

.193 - .213 (4.90 - 5.41 mm) DIA. THRU-2 HOLES

### 37895-1 FOOT MOUNTING BRACKET

Scale	A	B	C	D	E	F	G	H
Inches	.865 .886	2.115 2.135	1.843 1.875	2.421 2.453	.281 .343	.177 .197	.958 .978	3-1/8
mm	21.97 22.48	53.72 54.23	46.81 47.63	61.49 62.31	7.14 8.71	4.50 5.00	24.33 24.84	79.38

Scale	I	J	L	M	N	O	R	S
Inches	2	.333 .353	1.427 1.447	.833 .853	1.240 1.260	.615 .635	1.750 1.751	.640 .687
mm	50.80	8.46 8.97	36.25 36.75	21.16 21.67	31.50 32.00	15.62 16.13	44.45 44.48	16.26 17.45



## Series M007 Multi-Vane Air Motors

### Specifications



Model	Max. Power		Speed at Max. Power	Free Speed▲	Starting Torque		Stall Torque		Air Consumption at Max. Power		Weight	
	hp	kw	rpm	rpm	lb.-ft.	Nm	lb.-ft.	Nm	scfm	m <sup>3</sup> /m	lb.	kg
<b>Non-Reversible</b> Direction of rotation is counterclockwise when facing the shaft.												
M007RHR000AR4	0.85	0.63	11,000	22,000	0.58	0.79	0.77	1.04	36	1.02	3 <sup>1</sup> / <sub>16</sub>	1.4
M007RHR004AR4	0.82	0.61	2445	4890	2.39	3.24	3.19	4.33	36	1.02	3 <sup>1</sup> / <sub>16</sub>	1.4
M007RHR006AR4	0.82	0.61	1675	3350	3.50	4.75	4.66	6.32	36	1.02	3 <sup>1</sup> / <sub>16</sub>	1.4
M007RHR009AR4	0.82	0.61	1230	2460	4.76	6.45	6.34	8.60	36	1.02	3 <sup>1</sup> / <sub>16</sub>	1.4
M007RHR012AR4	0.79	0.59	870	1740	6.19	8.39	8.25	11.2	36	1.02	3 <sup>1</sup> / <sub>2</sub>	1.6
M007RHR015AR4	0.79	0.59	685	1370	7.80	10.6	10.4	14.1	36	1.02	3 <sup>1</sup> / <sub>2</sub>	1.6
M007RHR021AR4	0.79	0.59	470	940	11.5	15.6	15.3	20.7	36	1.02	3 <sup>1</sup> / <sub>2</sub>	1.6
M007RHR027AR4	0.79	0.59	370	740	14.5	19.7	19.3	26.2	36	1.02	3 <sup>1</sup> / <sub>2</sub>	1.6
M007RHR037AR4	0.79	0.59	270	540	19.7	26.7	26.3	35.7	36	1.02	3 <sup>1</sup> / <sub>2</sub>	1.6
M007RHR044AR4	0.79	0.59	232	465	23.2	31.5	30.9	41.9	36	1.02	3 <sup>1</sup> / <sub>2</sub>	1.6
M007RHR063BR6	0.79	0.59	161	321	33.5	45.4	44.7	60.6	36	1.02	7 <sup>1</sup> / <sub>8</sub>	3.2
M007RHR086BR6	0.79	0.59	118	236	45.7	62.0	60.9	82.6	36	1.02	7 <sup>1</sup> / <sub>8</sub>	3.2
M007RHR119BR6	0.76	0.57	82	163	60.5	82.0	80.7	109.0	36	1.02	7 <sup>1</sup> / <sub>8</sub>	3.4
M007RHR151BR6	0.76	0.57	65	129	76.5	104.0	102.0	138.0	36	1.02	7 <sup>1</sup> / <sub>8</sub>	3.4
M007RHR188BR6	0.76	0.57	52	103	96.0	130.0	128.0	174.0	36	1.02	7 <sup>1</sup> / <sub>8</sub>	3.4
M007RHR275BR6	0.76	0.57	35	70	*140.0	*190.0	*187.0	*254.0	36	1.02	7 <sup>1</sup> / <sub>8</sub>	3.4
M007RHR374BR6	0.76	0.57	26	52	*191.0	*259.0	*254.0	*344.0	36	1.02	7 <sup>1</sup> / <sub>8</sub>	3.4
<b>Reversible</b>												
M007RVR000AR4	0.70	0.52	10,000	20,000	0.47	0.64	0.63	0.85	33	0.93	3 <sup>1</sup> / <sub>16</sub>	1.4
M007RVR004AR4	0.67	0.50	2225	4450	1.94	2.63	2.59	3.51	33	0.93	3 <sup>1</sup> / <sub>16</sub>	1.4
M007RVR006AR4	0.67	0.50	1520	3045	2.84	3.85	3.78	5.13	33	0.93	3 <sup>1</sup> / <sub>16</sub>	1.4
M007RVR009AR4	0.67	0.50	1120	2240	3.86	5.23	5.14	6.97	33	0.93	3 <sup>1</sup> / <sub>16</sub>	1.4
M007RVR012AR4	0.64	0.48	790	1580	4.97	6.74	6.63	8.99	33	0.93	3 <sup>1</sup> / <sub>2</sub>	1.6
M007RVR015AR4	0.64	0.48	625	1250	6.29	8.53	8.38	11.4	33	0.93	3 <sup>1</sup> / <sub>2</sub>	1.6
M007RVR021AR4	0.64	0.48	425	855	9.2	12.5	12.2	16.5	33	0.93	3 <sup>1</sup> / <sub>2</sub>	1.6
M007RVR027AR4	0.64	0.48	335	675	11.6	15.7	15.5	20.1	33	0.93	3 <sup>1</sup> / <sub>2</sub>	1.6
M007RVR037AR4	0.64	0.48	245	495	15.8	21.4	21.1	28.6	33	0.93	3 <sup>1</sup> / <sub>2</sub>	1.6
M007RVR044AR4	0.64	0.48	210	420	18.6	25.2	24.8	33.6	33	0.93	3 <sup>1</sup> / <sub>2</sub>	1.6
M007RVR063BR6	0.64	0.48	146	292	26.9	36.5	35.9	48.7	33	0.93	7 <sup>1</sup> / <sub>8</sub>	3.2
M007RVR086BR6	0.64	0.48	107	215	36.7	49.8	48.9	66.3	33	0.93	7 <sup>1</sup> / <sub>8</sub>	3.2
M007RVR119BR6	0.61	0.46	74	148	48.1	65.3	64.1	87.0	33	0.93	7 <sup>1</sup> / <sub>8</sub>	3.4
M007RVR151BR6	0.61	0.46	58	117	61.0	82.7	81.3	110.0	33	0.93	7 <sup>1</sup> / <sub>8</sub>	3.4
M007RVR188BR6	0.61	0.46	47	94	76.5	104.0	102.0	138.0	33	0.93	7 <sup>1</sup> / <sub>8</sub>	3.4
M007RVR275BR6	0.61	0.46	32	64	*111.0	*151.0	*148.0	*201.0	33	0.93	7 <sup>1</sup> / <sub>8</sub>	3.4
M007RVR374BR6	0.61	0.46	23	47	*152.0	*206.0	*202.0	*274.0	33	0.93	7 <sup>1</sup> / <sub>8</sub>	3.4

▲ ALL models must be operated with sufficient load to prevent speed from exceeding maximum allowable speed shown on performance curve.

\* Applications with these models must be limited to 224 lb.-ft. (304 Nm) torque.

Performance figures are at 90 psig (620 kPa) air pressure.

Note: On all Series M002, M004, and M007 Air Motors, performance is the same for both directions of rotation. On Non-Reversible models, direction of rotation may be easily changed without the need of additional parts by inverting cylinder. See Assembly Instruction form number listed in price sheet.

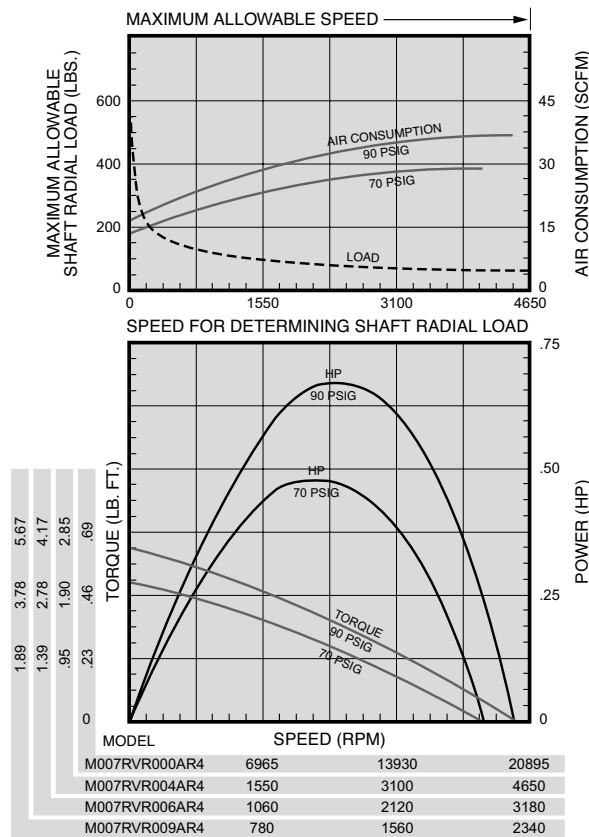
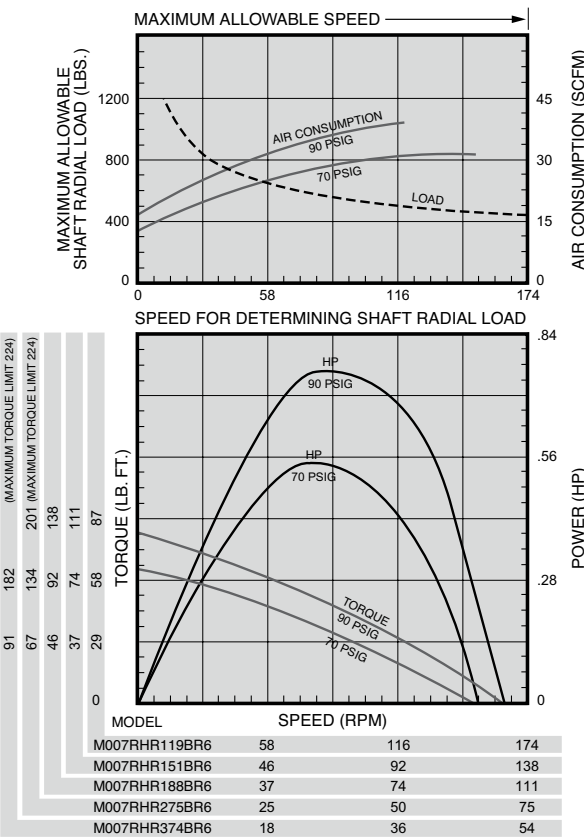
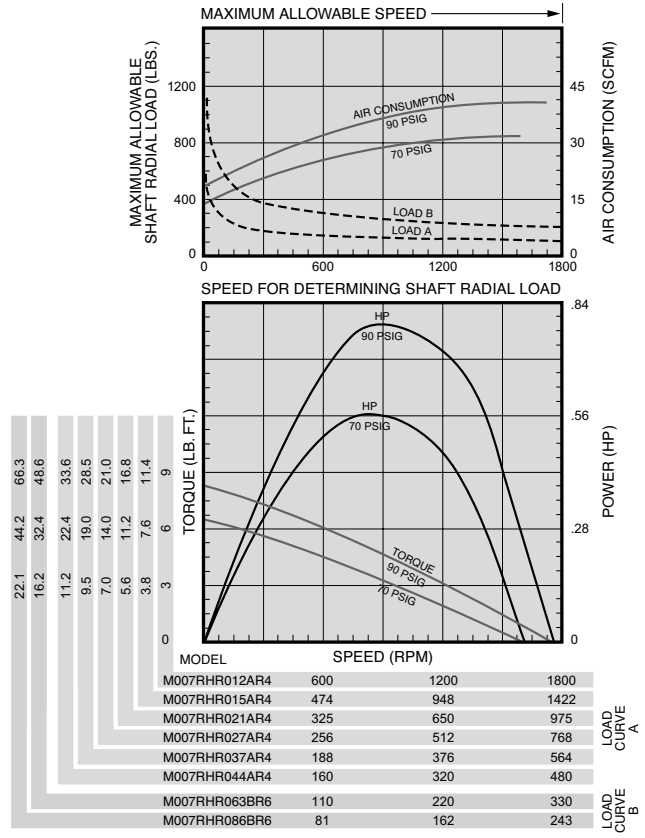
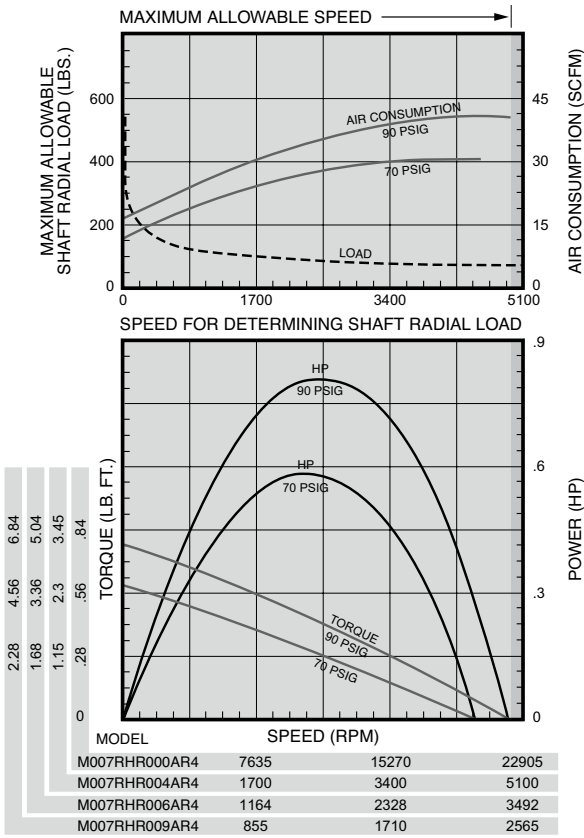

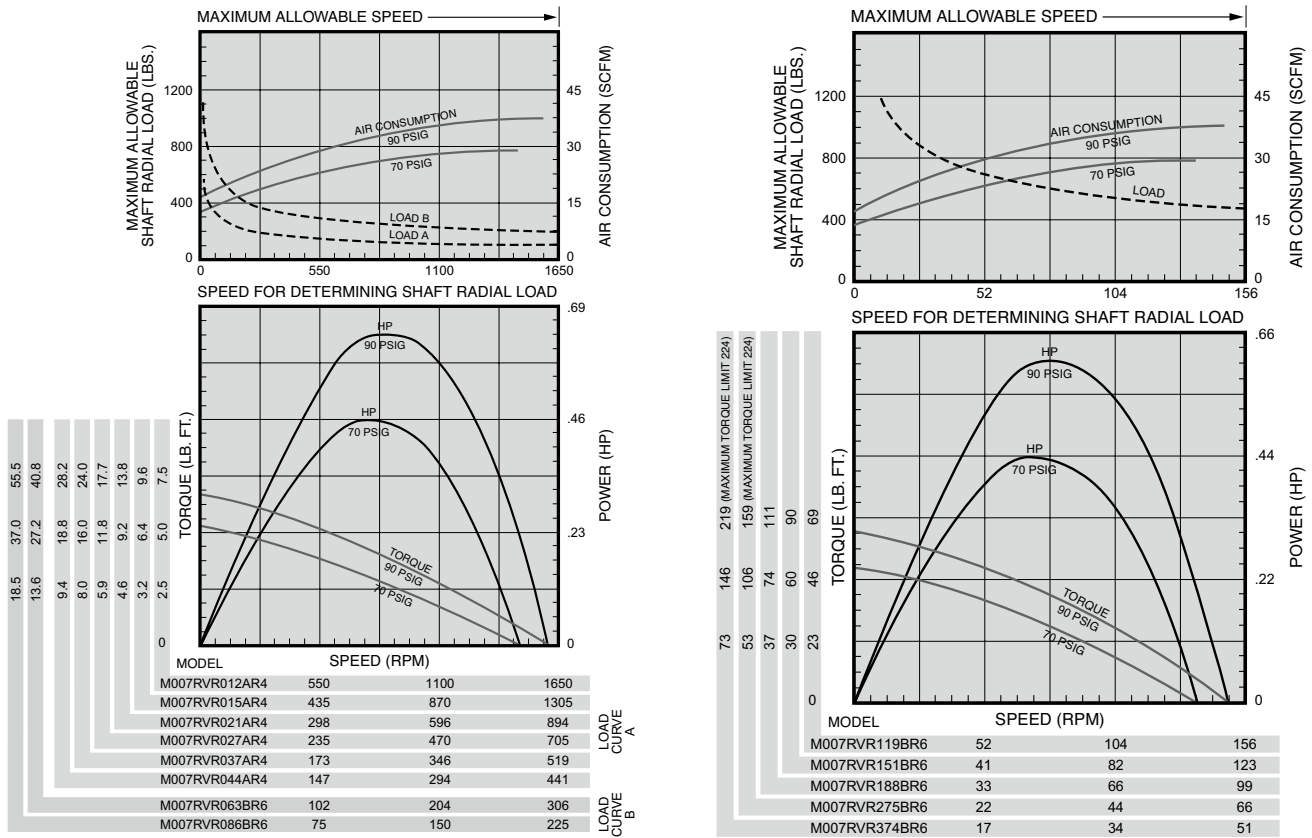

### Equipment Options

Furnished with Cataloged Models	Standard Options	Extra Options
2 Hole Flange Mounting on Gear Ratios: 000, 004, 006, 009, 012, 015, 021, 027, 037, 044	4 Hole Flange Mounting on Gear Ratios: 000, 004, 006, 009, 012, 015, 021, 027, 037, 044	½" Square Drive Shaft on Gear Ratios: 000, 004, 006, 009, 012, 015, 021, 027, 037, 044
6 Hole Face Mounting on Gear Ratios: 063, 086, 119, 151, 188, 275, 374	Side Inlet and Exhaust Housing (for Reversible Models only)	⅝" Square Drive Shaft on Gear Ratios: 063, 086, 119, 151, 188, 275, 374
½" Round Keyed Shaft on Gear Ratios: 000, 004, 006, 009, 012, 015, 021, 027, 037, 044	¾"—24 or ½"—20 Threaded Shaft on Gear Ratios: 000, 004, 006, 009, 012, 015, 021, 027, 037, 044	
¾" Round Keyed Shaft on Gear Ratios: 063, 086, 119, 151, 188, 275, 374		

## Series M007 Multi-Vane Air Motors

### Dimensions

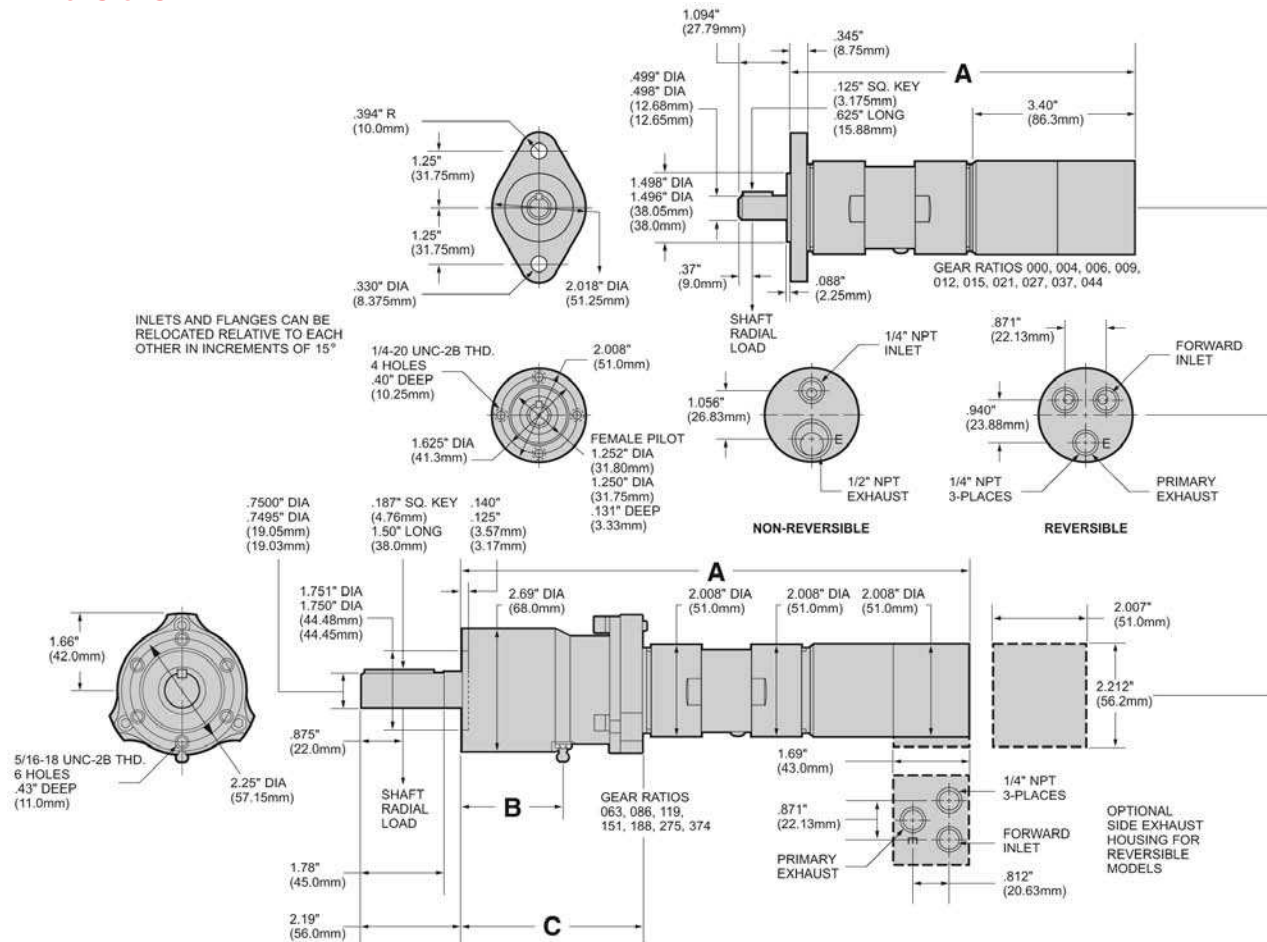

### Series M007 Model Number Symbolization

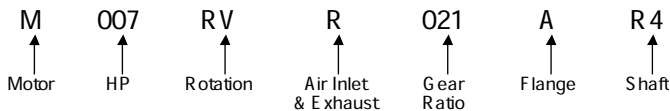

HP = Approximate horsepower range (.61 to .85)

Rotation = RV Reversible

RH Non-Reversible, Right Hand from Rear of Motor (CCW facing shaft)

LH Non-Reversible, Left Hand from Rear of Motor (CW facing shaft)

Air Inlet & Exhaust = R Rear, S Side (Side Inlet and Exhaust available on Reversible Models only)

Gear Ratio = 021 is 1 to 21, 027 is 1 to 27, etc.

Flange = A 2 Hole Flange, B 4 Hole Face Mounting (on 000, 004, 006, 009, 012, 015, 021, 027, 037, 044 gear ratios),

B 6 Hole Face Mounting (on 063, 086, 119, 151, 188, 275, 374 gear ratios)

Shaft = R4 1/2" Round Keyed (on 000, 004, 006, 009, 012, 015, 021, 027, 037, 044 gear ratios)

R6 3/4" Round Keyed (on 063, 086, 119, 151, 188, 275, 374 gear ratios)

S4 1/2" Square Drive (on 000, 004, 006, 009, 012, 015, 021, 027, 037, 044 gear ratios) Shaft Extension 1.31" (33.27 mm)

S5 5/8" Square Drive (on 063, 086, 119, 151, 188, 275, 374 gear ratios) Shaft Extension 1.25" (31.75 mm)

T3 3/8"-24 UNF-2A Threaded (on 000, 004, 006, 009, 012, 015, 021, 027, 037, 044 gear ratios) Shaft Extension .512" (13 mm)

T4 1/2"-20 UNF-2A Threaded (on 000, 004, 006, 009, 012, 015, 021, 027, 037, 044 gear ratios) Shaft Extension .512" (13 mm)

### Dimensions

Gear Ratios (Refer to Model No.)	A		B		C	
	in.	mm	in.	mm	in.	mm
000, 004, 006, 009	7.362	187.0				
012, 015, 021, 027, 037, 044	8.133	206.56				
063, 086	9.343	237.3	.41	10	2.3	58.4
119, 188, 275, 374, 151	10.937	277.8	2.19	56	3.9	99.0





## 2200-Series Power Motors (with Thread-On Gearing)

### Specifications

MODEL	SPINDLE	TORQUE				AIR CONSUMPTION				SOUND LEVEL @FREE SPEED dB(A)	WEIGHT		GEAR REDUCTION
		R.P.M. FREE LOAD SPEED	STALL	OUTPUT @MAX. H.P.	CONSUMPTION @FREE SPEED	lb. ft.	Nm	lb. ft.	Nm		SCFM	L/s	
<b>NON-REVERSIBLE - .85 H.P.</b>													
<b>7800-B</b>	1/2" Keyed	18,000	9,000	1.00	1.4	.50	.68	41.7	19.7	78	4.24	1.91	Single
<b>7801-B</b>	1/2" Keyed	4,600	2,400	4.00	5.5	1.86	2.5	41.7	19.7	78	4.24	1.91	Single
<b>7802-B</b>	1/2" Keyed	2,500	1,300	7.50	10.3	3.43	4.7	41.7	19.7	78	4.24	1.91	Single
<b>7803-B</b>	1/2" Keyed	1,200	600	16.00	21.9	7.44	10.2	41.7	19.7	78	5.17	2.33	Double
<b>7804-B</b>	1/2" Keyed	650	320	30.00	41.2	13.95	19.1	41.7	19.7	78	5.17	2.33	Double
<b>7805-B</b>	1/2" Keyed	350	170	55.00	75.5	26.25	36.0	41.7	19.7	78	5.17	2.33	Double
<b>7812-B</b>	1/2"-20 Th'd.	350	170	55.00	75.5	26.25	36.0	41.7	19.7	78	5.17	2.33	Double
<b>7813-B</b>	1/2"-20 Th'd.	650	320	30.00	41.2	13.95	19.1	41.7	19.7	78	5.17	2.33	Double
<b>7814-B</b>	1/2"-20 Th'd.	18,000	9,000	1.00	1.4	.50	.68	41.7	19.7	78	4.24	1.91	Single
<b>7815-B</b>	1/2"-20 Th'd.	1,200	600	16.00	21.9	7.44	10.2	41.7	19.7	78	5.17	2.33	Double
<b>7816-B</b>	1/2"-20 Th'd.	4,600	2,400	4.00	5.5	1.86	2.5	41.7	19.7	78	4.24	1.91	Single
<b>7817-B</b>	1/2"-20 Th'd.	2,500	1,300	7.50	10.3	3.43	4.7	41.7	19.7	78	4.24	1.91	Single
<b>REVERSIBLE - .70 H.P.</b>													
<b>7806-B</b>	1/2" Keyed	13,500	7,000	1.00	1.4	.52	.71	37.3	17.6	85*	4.24	1.91	Single
<b>7807-B</b>	1/2" Keyed	3,400	1,800	4.00	5.5	2.04	2.8	37.3	17.6	85*	4.24	1.91	Single
<b>7808-B</b>	1/2" Keyed	1,800	1,000	7.40	10.2	3.67	5.0	37.3	17.6	85*	4.24	1.91	Single
<b>7809-B</b>	1/2" Keyed	850	450	15.50	21.3	8.16	11.2	37.3	17.6	85*	5.17	2.33	Double
<b>7810-B</b>	1/2" Keyed	450	240	29.00	39.8	15.30	21.0	37.3	17.6	85*	5.17	2.33	Double
<b>7811-B</b>	1/2" Keyed	250	130	54.00	74.0	28.20	38.7	37.3	17.6	85*	5.17	2.33	Double

\*R requires installation for reversible motors - shown on page 88.

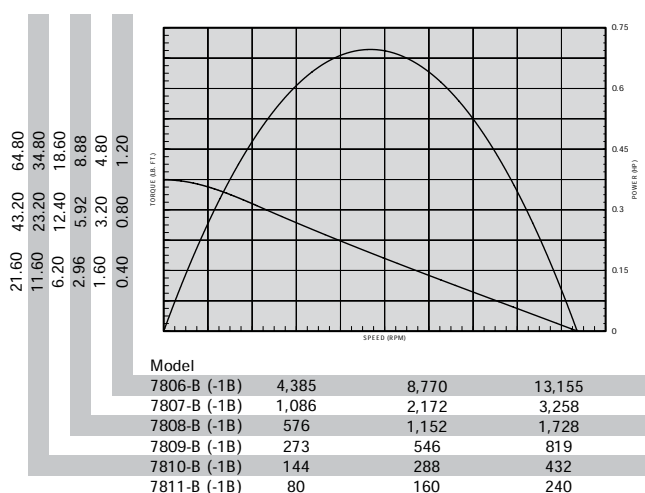
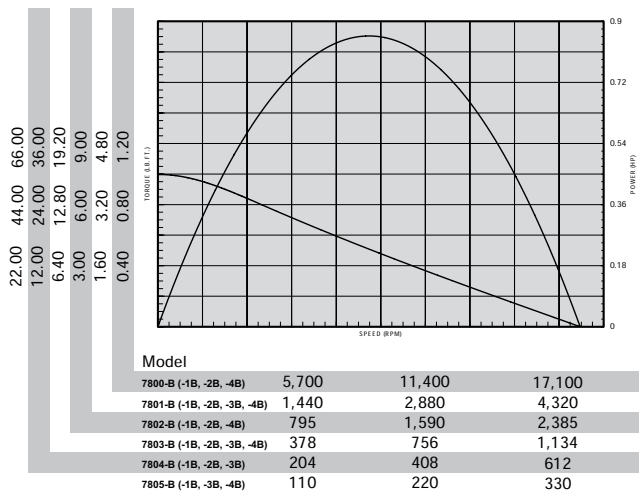

### Standard Equipment

Steel motor housing, flush-type grease fittings at rotation points for gear and bearing lubrication, exhaust manifold rotatable within 360°, and muffler.



### Equipment Options

- 37893 Flange Bracket
- 37894 Foot Bracket



### Options for Forward-Rotation Models with Threaded Spindles

- 40768 1/2" (12.7 mm) Male Square-Drive Adapter
- 31651 1/2" (12.7 mm) I.D. Female Stirring Rod Adapter, 3/8"-24 Thd.
- 33907 3/8" (9.5 mm) Cap. Drill Chuck
- 30018 1/2" (12.7 mm) Cap. Drill Chuck

## 2200-Series Power Motors and Mounting Accessory Dimensions

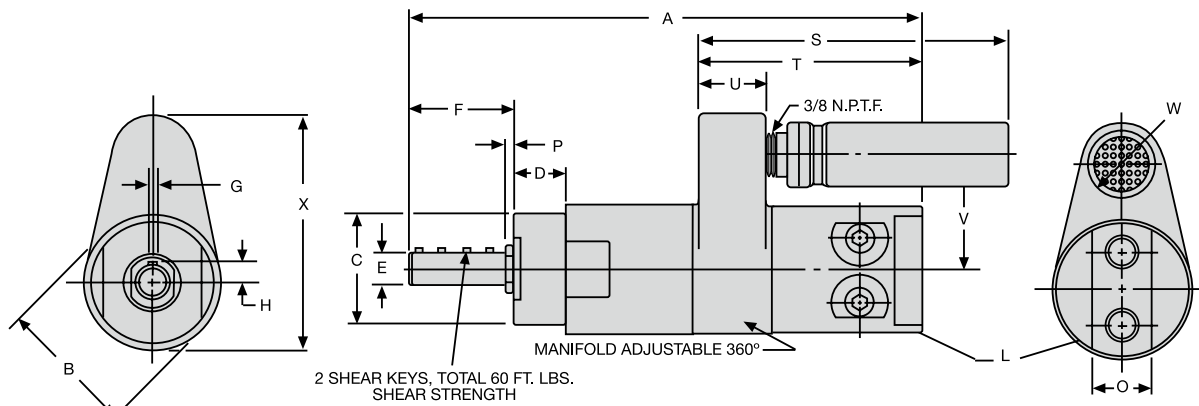

REVERSIBLE ROTATION, SINGLE REDUCTION SHOWN

DIMENSION A		
Gear Reduction	Threaded Spindle	Keyed Spindle
Single	7 178 mm	8 203 mm
Double	8-7/8 225 mm	9-3/4 248 mm

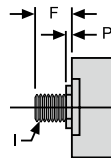

THREADED SPINDLE

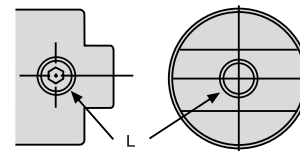

AIR INLETS,  
FORWARD-ROTATION MOTORS

Scale	B	C	D	E	F-Keyed Spindle	F-Th'd. Spindle	G	H	I	L
Inches	2	1.740 1.760	.818 .838	.4990 .4995	1.588 1.646	.619 .677	.125 .126	.299 .309	1/2-20 UNF-2A	1/4 NPTF
mm	51	44.20 44.70	20.78 21.29	12.67 12.69	40.34 41.81	15.72 17.20	3.18 3.20	7.59 7.85	Thread	Air Inlet

Scale	O	P	S	T	U	V	W-Fwd. Rotation	W Reversible	X-Fwd. Rotation	X Reversible
Inches	7/8	.046 .158	4-7/8	3-1/2	1-1/16	1-13/16	1-3/8	1	3-1/2	3-7/16
mm	22	1.17 4.01	124	89	27	46	35	25	89	87

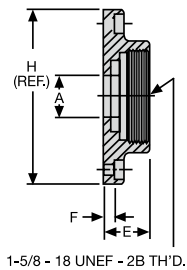

1-5/8 - 18 UNEF - 2B TH'D.

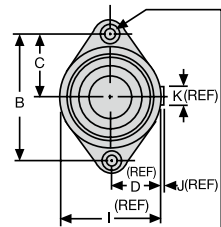

.193 - .213 (4.90 - 5.41 mm) DIA. THRU C'BORE .365 - .385 (9.27 - 9.78 mm) DIA. DEPTH SHOWN - 2 HOLES

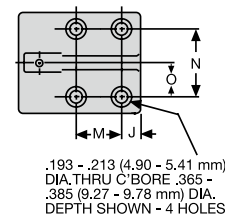
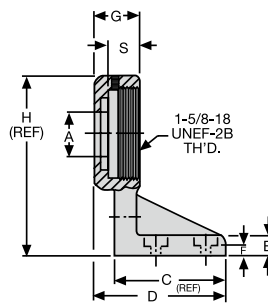

.193 - .213 (4.90 - 5.41 mm) DIA. THRU C'BORE .365 - .385 (9.27 - 9.78 mm) DIA. DEPTH SHOWN - 4 HOLES

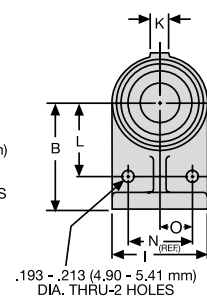

.193 - .213 (4.90 - 5.41 mm) DIA. THRU-2 HOLES

37893 FLANGE MOUNTING BRACKET

Scale	A	B	C	D	E
Inches	.771 .791	2.480 2.520	1.240 1.260	31/32	.771 .791
mm	19.58 20.09	62.99 64.00	31.50 32.00	24.61	19.58 20.09

37894 FOOT MOUNTING BRACKET

Scale	A	B	C	D	E	F	G	H
Inches	.771 .791	2.115 2.135	1.843 1.906	2-7/32	.365 .385	.177 .197	.828 .859	3-1/6
mm	19.58 20.09	53.72 54.23	46.81 48.41	56.36	9.27 9.80	4.50 5.00	21.03 21.82	77.79

Scale	F	H	I	J	K
Inches	.177 .197	3	1-15/16	1/16	3/8
mm	4.50 5.00	76.20	49.21	1.59	9.53

Scale	I	J	K	L	M	N	O	S
Inches	1-7/8	.334 .354	.312 .437	1.427 1.447	.834 .854	1.240 1.260	.615 .635	.511 .531
mm	47.63	8.84 8.99	8.92 11.10	36.25 36.75	21.18 21.69	31.50 32.00	15.62 16.13	12.98 13.49

## 2200-Series Power Motors (with Bolt-On Gearing)

### Specifications

MODEL	SPINDLE	R.P.M.		TORQUE				AIR CONSUMPTION		SOUND LEVEL @FREE SPEED dB(A)	WEIGHT		GEAR REDUCTION
		FREE LOAD SPEED	STALL	OUTPUT @MAX. H.P.	STALL	OUTPUT @MAX. H.P.	STALL	OUTPUT @MAX. H.P.	@FREE SPEED		L/s	lbs.	
<b>NON-REVERSIBLE - .85 H.P.</b>													
<b>7800-1B</b>	1/2" Keyed	18,000	9,000	1.00	1.4	.50	.68	41.7	19.7	78	4.24	1.91	Single
<b>7801-1B</b>	1/2" Keyed	4,600	2,400	4.00	5.5	1.86	2.5	41.7	19.7	78	4.24	1.91	Single
<b>7802-1B</b>	1/2" Keyed	2,500	1,300	7.50	10.3	3.43	4.7	41.7	19.7	78	4.24	1.91	Single
<b>7803-1B</b>	1/2" Keyed	1,200	600	16.00	21.9	7.44	10.2	41.7	19.7	78	5.17	2.33	Double
<b>7804-1B</b>	1/2" Keyed	650	320	30.00	41.2	13.95	19.1	41.7	19.7	78	5.17	2.33	Double
<b>7805-1B</b>	1/2" Keyed	350	170	55.00	75.5	26.25	36.0	41.7	19.7	78	5.17	2.33	Double
<b>7812-1B</b>	1/2"-20 Th'd.	350	170	55.00	75.5	26.25	36.0	41.7	19.7	78	5.17	2.33	Double
<b>7813-1B</b>	1/2"-20 Th'd.	650	320	30.00	41.2	13.95	19.1	41.7	19.7	78	5.17	2.33	Double
<b>7814-1B</b>	1/2"-20 Th'd.	18,000	9,000	1.00	1.4	.50	.68	41.7	19.7	78	4.24	1.91	Single
<b>7815-1B</b>	1/2"-20 Th'd.	1,200	600	16.00	21.9	7.44	10.2	41.7	19.7	78	5.17	2.33	Double
<b>7816-1B</b>	1/2"-20 Th'd.	4,600	2,400	4.00	5.5	1.86	2.5	41.7	19.7	78	4.24	1.91	Single
<b>7817-1B</b>	1/2"-20 Th'd.	2,500	1,300	7.50	10.3	3.43	4.7	41.7	19.7	78	4.24	1.91	Single
<b>REVERSIBLE - .70 H.P.</b>													
<b>7806-1B</b>	1/2" Keyed	13,500	7,000	1.00	1.4	.52	.71	37.3	17.6	85*	4.36	1.96	Single
<b>7807-1B</b>	1/2" Keyed	3,400	1,800	4.00	5.5	2.04	2.8	37.3	17.6	85*	4.36	1.96	Single
<b>7808-1B</b>	1/2" Keyed	1,800	1,000	7.40	10.2	3.67	5.0	37.3	17.6	85*	4.36	1.96	Single
<b>7809-1B</b>	1/2" Keyed	850	450	15.50	21.3	8.16	11.2	37.3	17.6	85*	5.67	2.55	Double
<b>7810-1B</b>	1/2" Keyed	450	240	29.00	39.8	15.30	21.0	37.3	17.6	85*	5.67	2.55	Double
<b>7811-1B</b>	1/2" Keyed	250	130	54.00	74.0	28.20	38.7	37.3	17.6	85*	5.67	2.55	Double

\*R requires installation for reversible motors - shown on page 88.

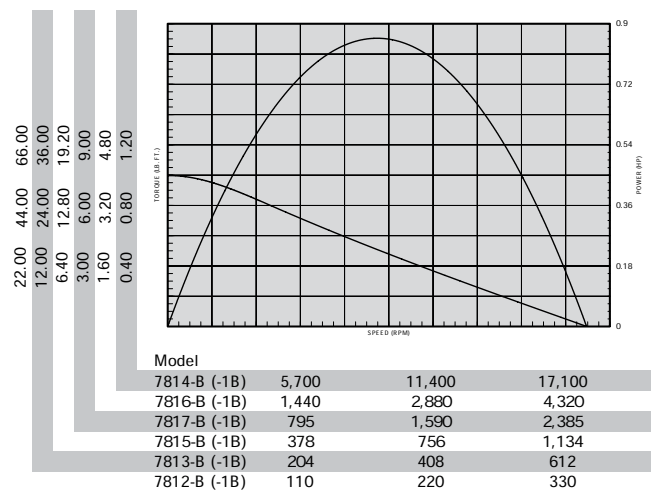
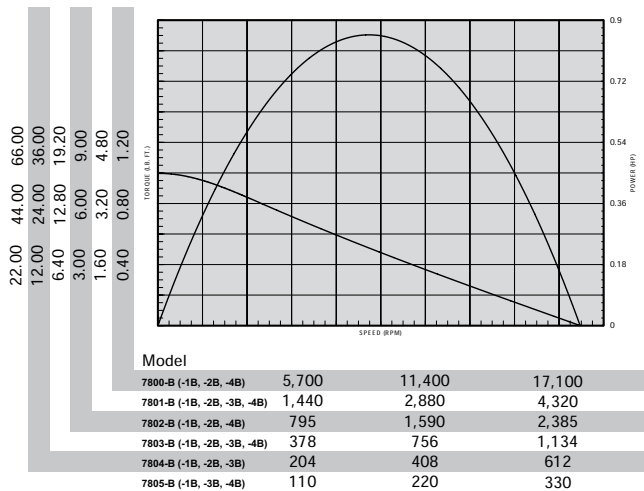

### Standard Equipment

Steel motor housing, flush-type grease fittings at rotation points for gear and bearing lubrication, exhaust manifold rotatable within 360°, and muffler.



### Equipment Options

37895-1 Foot Bracket  
Provisions for flange mounting is standard on all models.



### Options for Forward-Rotation Models with Threaded Spindles

- 40768 1/2" (12.7 mm) Male Square-Drive Adapter
- 31651 1/2" (12.7 mm) I.D. Female Stirring Rod Adapter
- 33907 3/8" (9.5 mm) Cap. Drill Chuck
- 30018 1/2" (12.7 mm) Cap. Drill Chuck

## 2200-Series Power Motors and Mounting Accessory Dimensions

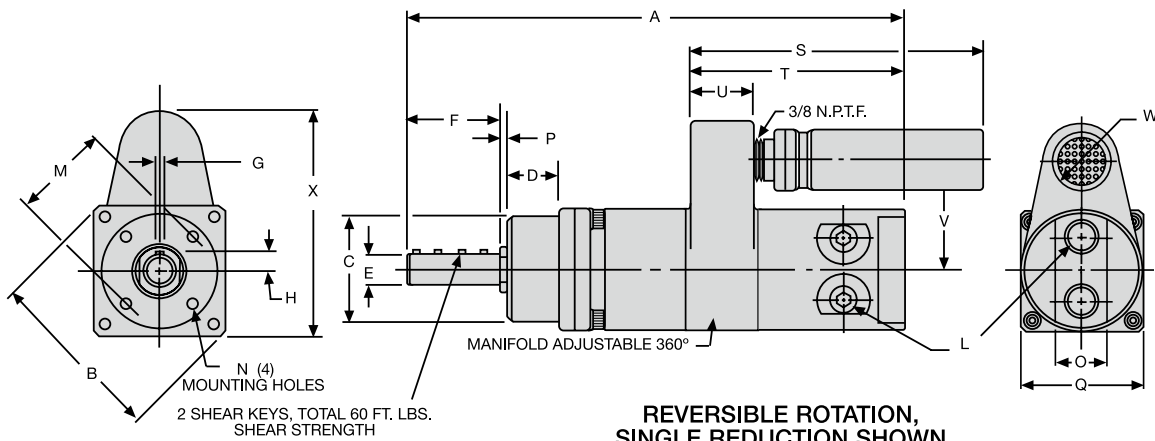

REVERSIBLE ROTATION,  
SINGLE REDUCTION SHOWN

Models	Gear Reduction	DIMENSION A
7800-1B 7801-1B 7802-1B	Single	8-1/8
7806-1B 7807-1B 7808-1B		206 mm
7803-1B 7804-1B 7805-1B	Double	9-29/32
7809-1B 7810-1B 7811-1B		252 mm
7814-1B 7816-1B 7817-1B	Single	7-5/32
		182 mm
7812-1B 7813-1B 7815-1B	Double	8-15/16
		227 mm

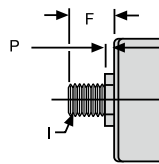

THREADED  
SPINDLE

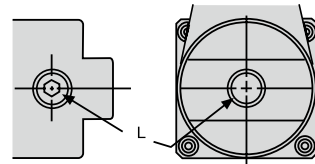

AIR INLETS,  
SINGLE DIRECTION MOTORS

Scale	B	C	D	E	F-Keyed Spindle	F-Th'd Spindle	G	H	I	L	M	N
Inches	2-11/16	1.7490 1.7495	.781 .812	.4990 .4995	1.615 1.653	.646 .684	.125 .126	.299 .309	1/2"-20 UNF-2A	1/4 NPTF	1.432 1.442	10-24 UNC-2B
mm	68	44.42 44.44	19.84 20.62	12.67 12.69	41.02 41.99	16.41 17.37	3.18 3.20	7.59 7.85	Thread	Air Inlet	36.37 36.63	Thread

Scale	O	P	Q	S	T	U	V	W-Fwd. Rotation R	W ibl	X-Fwd. Rotation R	X ibl
Inches	7/8	.113 .165	2	4-7/8	3-1/2	1-1/16	1-13/16	1-3/8	1	3-1/2	3-7/16
mm	22	2.87 4.19	51	124	89	27	46	35	25	89	87

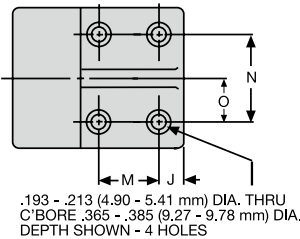
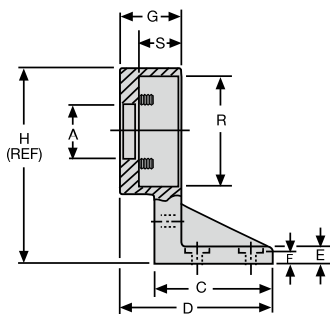

.193 - .213 (4.90 - 5.41 mm) DIA. THRU  
C'BORE .365 - .385 (9.27 - 9.78 mm) DIA. X  
.193 - .213 DEEP (FOR Y154-51 SCREWS)

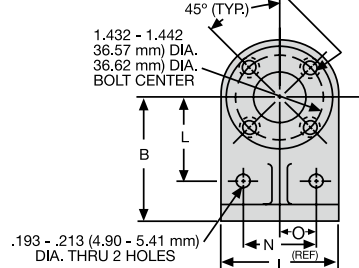

37895-1 FOOT MOUNTING BRACKET

Scale	A	B	C	D	E	F	G	H
Inches	.865 .886	2.115 2.135	1.843 1.875	2.421 2.453	.281 .343	.177 .197	.958 .978	3-1/8
mm	21.97 22.48	53.72 54.23	46.81 47.63	61.49 62.31	7.14 8.71	4.50 5.00	24.33 24.84	79.38

Scale	I	J	L	M	N	O	R	S
Inches	2	.333 .353	1.427 1.447	.833 .853	1.240 1.260	.615 .635	1.750 1.751	.640 .687
mm	50.80	8.46 8.97	36.25 36.75	21.16 21.67	31.50 32.00	15.62 16.13	44.45 44.48	16.26 17.45

## 2200-Series Power Motors (with 44-Series Gearing) Specifications

MODEL	SPINDLE	R.P.M.		TORQUE		OUTPUT		AIR		SOUND LEVEL @FREE SPEED dB(A)	WEIGHT		GEAR REDUCTION
		FREE SPEED	LOAD SPEED @MAX. H.P.	STALL lb. ft.	Nm	@MAX. H.P. lb. ft.	Nm	CONSUMPTION @FREE SPEED SCFM	L/s		lbs.	kg.	
<b>NON-REVERSIBLE - .90 H.P.</b>													
8276-1A	7/8" Keyed	700	350	27.0	37.0	13.5	18.5	41.6	19.6	78	10.10	4.55	2
8276-2A	7/8" Keyed	350	180	50.0	68.0	26.0	36.0	41.6	19.6	78	10.10	4.55	2
8276-3A	7/8" Keyed	300	150	60.0	82.0	32.0	43.0	41.6	19.6	78	14.50	6.52	3
8276-4A	7/8" Keyed	160	90	105.0	143.0	53.0	72.0	41.6	19.6	78	14.50	6.52	3
8276-5A**	7/8" Keyed	100	50	**150.0	206.0	95.0	130.0	41.6	19.6	78	14.50	6.52	3
8276-6A**	7/8" Keyed	50	25	**150.0	206.0	**150.0	206.0	41.6	19.6	78	14.50	6.52	3
<b>REVERSIBLE - .65 H.P.</b>													
8274-A	7/8" Keyed	800	450	13.0	18.0	7.6	10.5	35.0	16.5	83*	10.10	4.55	2
8274-1A	7/8" Keyed	475	250	23.0	32.0	14.0	19.0	35.0	16.5	83*	10.10	4.55	2
8274-2A	7/8" Keyed	250	130	43.0	59.0	26.0	36.0	35.0	16.5	83*	10.10	4.55	2
8274-3A	7/8" Keyed	200	110	52.0	71.0	31.0	42.0	35.0	16.5	83*	14.50	6.52	3
8274-4A	7/8" Keyed	120	60	91.0	125.0	57.0	78.0	35.0	16.5	83*	14.50	6.52	3
8274-5A**	7/8" Keyed	65	35	**150.0	206.0	98.0	134.0	35.0	16.5	83*	14.50	6.52	3
8274-6A**	7/8" Keyed	35	18	**150.0	206.0	**150.0	206.0	35.0	16.5	83*	14.50	6.52	3

\*R requires installation for reversible motors - shown on page 88.

\*\*NOTE: Maximum torque recommended for planetary gear system requires shear key with 150 ft./lbs. shear strength.

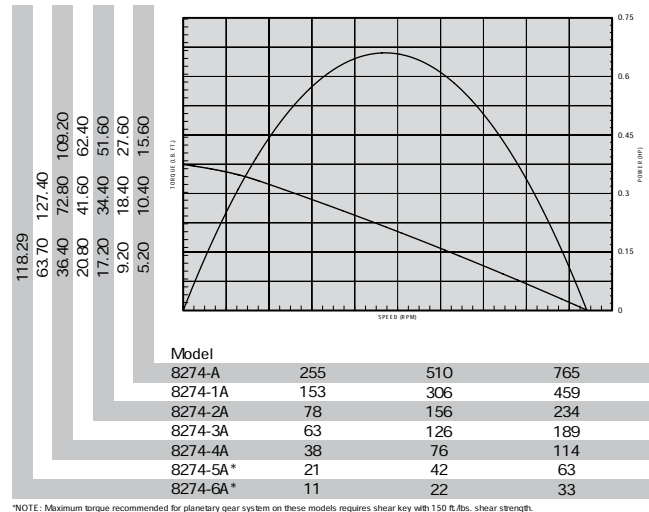
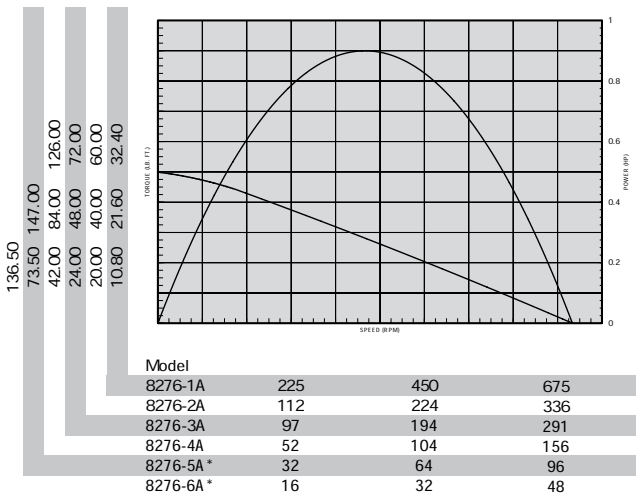

### Standard Equipment

Steel motor housing, flush-type grease fittings at rotation points for gear and bearing lubrication, exhaust manifold rotatable within 360°, and muffler.



### Equipment Options

37892-1 Foot Bracket

NOTE: Gear housing has precision pilot diameter and four mounting holes (5/16"-24) for flange mounting.

37892-1

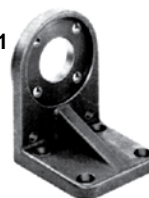

### Options for Specified Models

- 41784 3/4" (19.2 mm) Male Square-Drive Adapter for 7/8" (22.23 mm) keyed spindle
- 41512 Throttle & Bracket Assembly for forward-rotation nutsetters.
- 41512-1 Throttle & Bracket Assembly for reversible nutsetters. Includes two 41511 throttles and two 43982-1 Quick-Dump Exhaust Valves.



## 2200/44-Series Power Motors and Mounting Accessory Dimensions

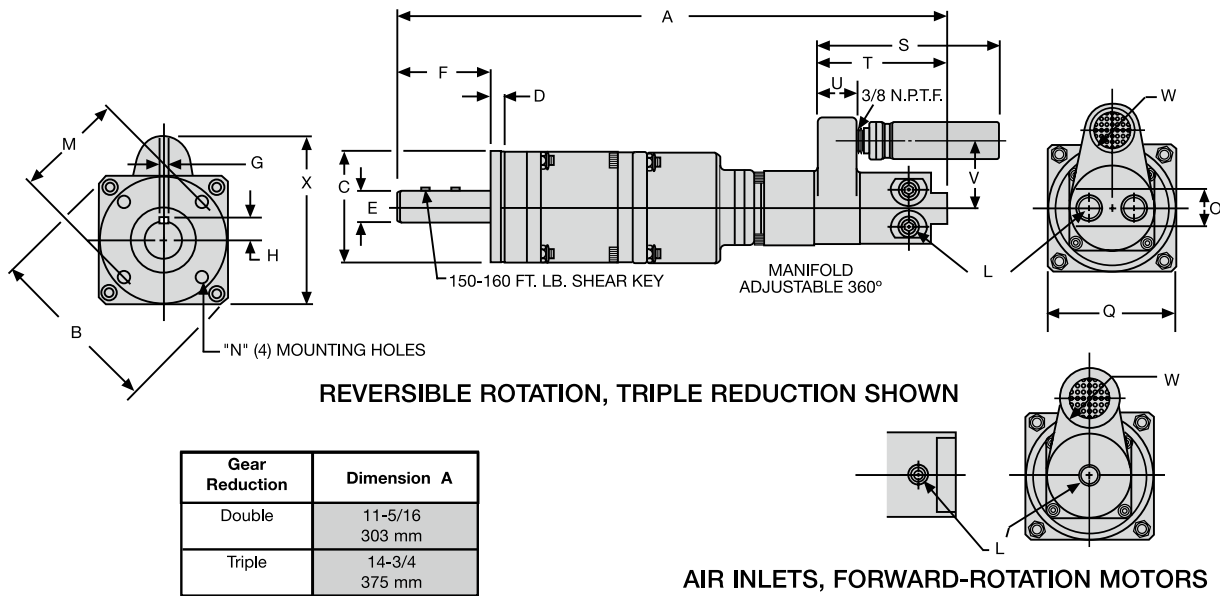

Gear Reduction	Dimension A
Double	11-5/16 303 mm
Triple	14-3/4 375 mm

**AIR INLETS, FORWARD-ROTATION MOTORS**

Scale	B	C	D	E	F	G	H	L	M	N
Inches	4.090	2.996	.369	.8743	2.483	.1872	.528	1/4	2.495	5/16-24
	4.110	2.998	.374	.8748	2.559	.1875	.531	NPTF	2.505	UNF-2B
mm	103.89	76.10	9.37	22.21	63.07	4.75	13.41	Air	63.37	Thread
	104.39	76.15	9.50	22.22	65.00	4.76	13.49	Inlet	63.63	

Scale	O	Q	S	T	U	V	W-Fwd. Rotation	W Reversible	X Reversible	X Single
Inches	7/8	3	4-7/8	3-1/2	1-1/6	1-13/16	1-3/8	1	3-15/16	4
mm	22	76	124	89	27	46	35	25	100	102

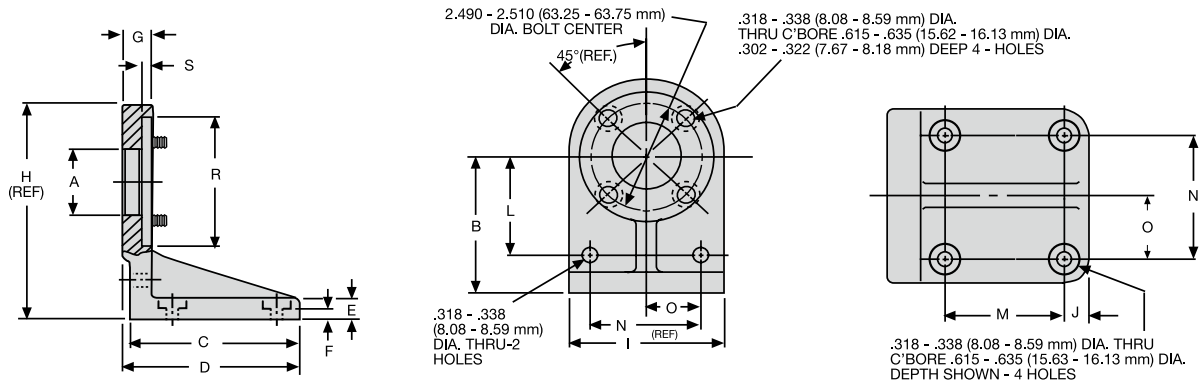

Scale	A	B	C	D	E	F	G	H
Inches	1.490	3.115	3.781	3.968	.437	.240	.671	4.812
	1.510	3.135	3.843	4.062	.562	.260	.718	4.937
mm	37.85	79.12	96.04	100.79	11.10	6.10	17.04	122.22
	38.35	79.63	97.61	103.17	14.27	6.60	18.24	125.40

Scale	I	J	L	M	N	O	R	S
Inches	3-1/2	.490	2.240	2.365	2.490	1.240	2.999	.240
		.510	2.260	2.385	2.510	1.260	3.000	.260
mm	88.90	12.45	56.90	60.07	63.25	31.50	76.17	6.10
		12.95	57.40	60.58	63.75	32.00	76.20	6.60

## Series 1801 and 1841 Multi-Vane Air Motors Specifications



Model	Max. Power		Speed at Max. Power	Free Speed▲	Starting Torque		Stall Torque		Air Consumption at Max. Power		Weight	
	hp	kw	rpm	rpm	lb.-ft.	Nm	lb.-ft.	Nm	scfm	m <sup>3</sup> /m	lb.	kg
<b>Non-Reversible</b> Direction of rotation is counterclockwise when facing the shaft.												
1801N	1.40	1.04	918	1990	10.5	14.2	14	19.0	46	1.3	5½	2.44
1801P	1.35	1.01	500	1050	17.2	23.3	23	31.2	46	1.3	5½	2.61
1801Q	1.35	1.01	300	650	30.0	40.7	40	54.2	46	1.3	5½	2.61
1801U	1.35	1.01	205	435	41.0	55.6	55	74.6	46	1.3	5½	2.61
1801W	1.35	1.01	175	370	52.0	70.5	70	94.9	46	1.3	5½	2.61
<b>Reversible</b>												
1841N	1.2	.89	800	1700	9.3	12.6	12.5	17.0	43	1.22	5½	2.50
1841P	1.1	.82	430	900	15.0	20.3	20.0	27.1	43	1.22	5½	2.67
1841Q	1.1	.82	260	550	27.0	36.6	36.0	48.8	43	1.22	5½	2.67
1841U	1.1	.82	175	380	37.0	50.2	50.0	67.8	43	1.22	5½	2.67
1841W	1.1	.82	150	320	45.0	61.0	60.0	81.4	43	1.22	5½	2.67

▲ ALL models must be operated with sufficient load to prevent speed from exceeding maximum allowable speed shown on performance curve. Performance figures are at 90 psig (620 kPa) air pressure.

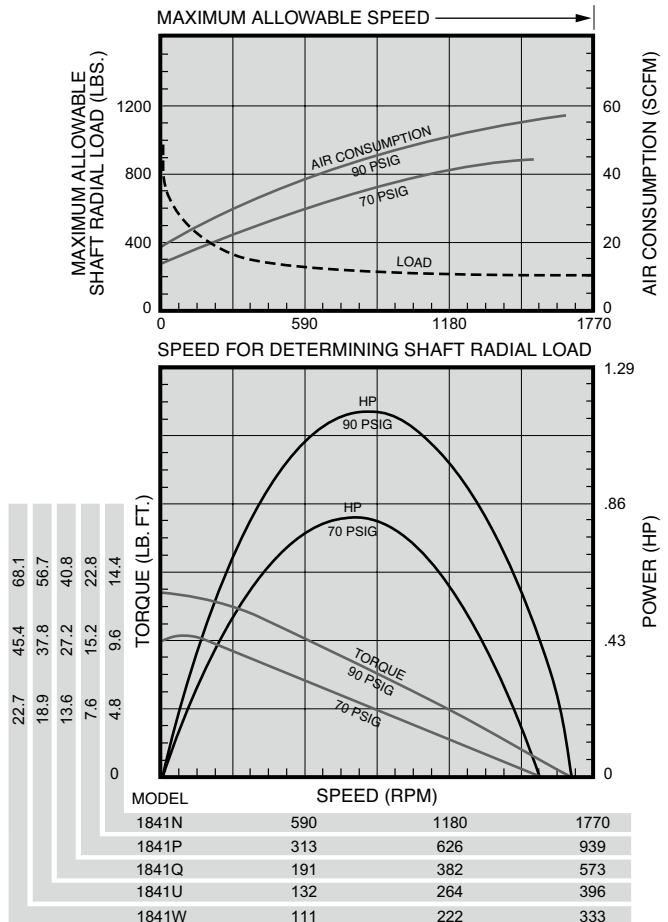
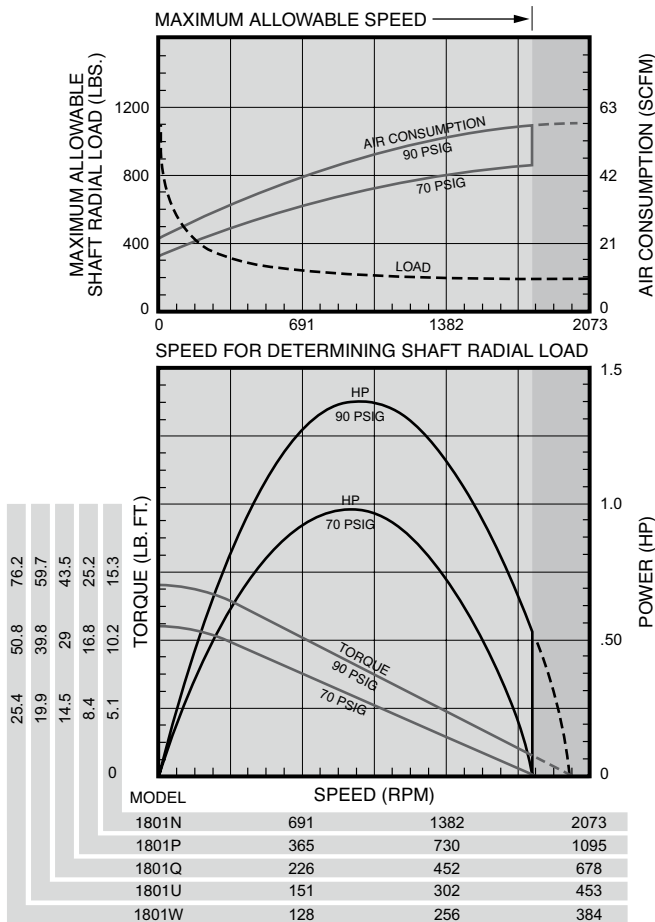

## Series 1801 and 1841 Multi-Vane Air Motors

### Dimensions

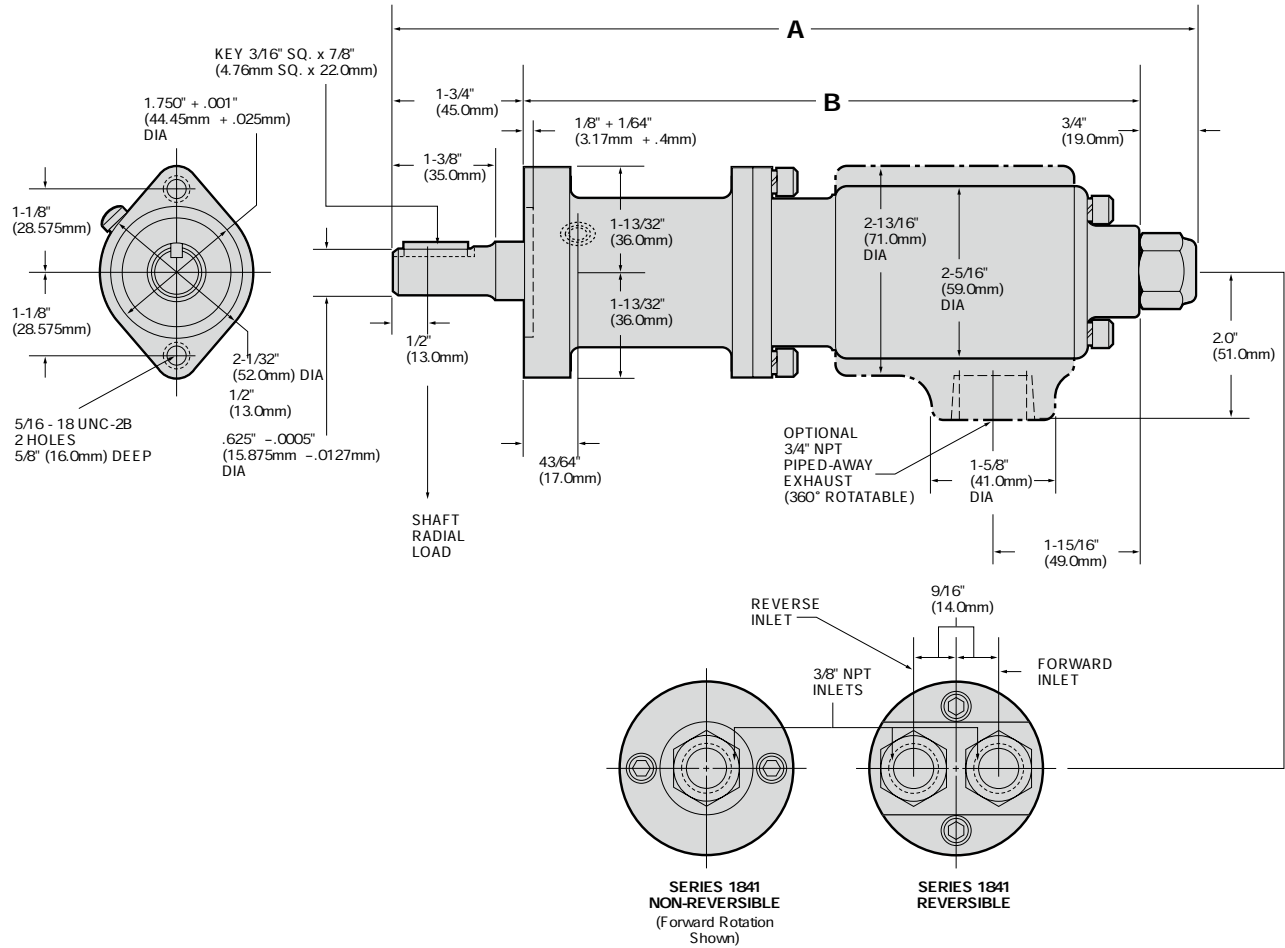

### Dimensions

Models	A		B	
	in.	mm	in.	mm
1801N, 1841N	9 <sup>5</sup> / <sub>16</sub>	240	6 <sup>15</sup> / <sub>16</sub>	176
1801P, 1801Q, 1801U, 1801W, 1841P, 1841Q, 1841U, 1841W	10 <sup>3</sup> / <sub>16</sub>	275	8 <sup>5</sup> / <sub>16</sub>	211

### Equipment Options

Furnished with Cataloged Models	Extra Options
2 Hole Face Mounting	R1801-A123 Exhaust Deflector Assembly with 3/8" Pipe Tap
	*1/2" Square Drive Shaft on Gear Ratios: P, Q, U Shaft Extension 1.19" (30.23mm)

\*To order Motor with Square Drive Shaft, add the suffix "2" to the Model Number. Example: 1841Q2.

## Series 3800 and 3840 Multi-Vane Air Motors Specifications



Model	Max. Power		Speed at Max. Power	Free Speed▲	Starting Torque		Stall Torque		Air Consumption at Max. Power		Weight	
	hp	kw	rpm	rpm	lb.-ft.	Nm	lb.-ft.	Nm	scfm	m <sup>3</sup> /m	lb.	kg
<b>Non-Reversible</b> Direction of rotation is counterclockwise when facing the shaft.												
3800M	1.55	1.16	520	1100	24	32.5	33	44.8	48	1.36	7½	3.23
3800P	1.45	1.08	285	600	42	57	56.5	76.6	48	1.36	8½	3.86
3800Q	1.45	1.08	180	375	62	84	83.5	113	48	1.36	8½	3.86
3800R	1.45	1.08	150	320	72	98	96	130	48	1.36	8½	3.86
3800S	1.45	1.08	120	255	88	119	118	160	48	1.36	8½	3.86
3800U	1.45	1.08	105	220	105	142	140	189	48	1.36	8½	3.86
<b>Reversible</b>												
3840M	1.40	1.04	390	825	23	31.2	31.5	42.7	44	1.25	7%	3.35
3840P	1.35	1.01	215	440	40	54.2	53.5	72.6	44	1.25	8%	3.97
3840Q	1.35	1.01	130	280	60	81.4	80	106	44	1.25	8%	3.97
3840R	1.35	1.01	122	238	69	93	92	125	44	1.25	8%	3.97
3840S	1.35	1.01	100	190	86	116	115	156	44	1.25	8%	3.97
3840U	1.35	1.01	83	162	100	135	134	181	44	1.25	8%	3.97

▲ ALL models must be operated with sufficient load to prevent speed from exceeding maximum allowable speed shown on performance curve. Performance figures are at 90 psig (620 kPa) air pressure.

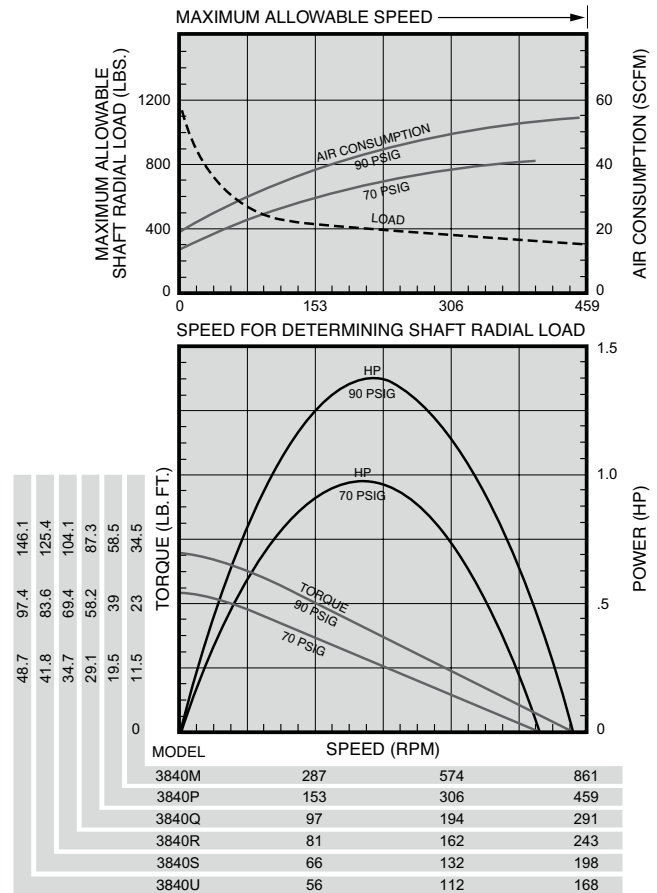
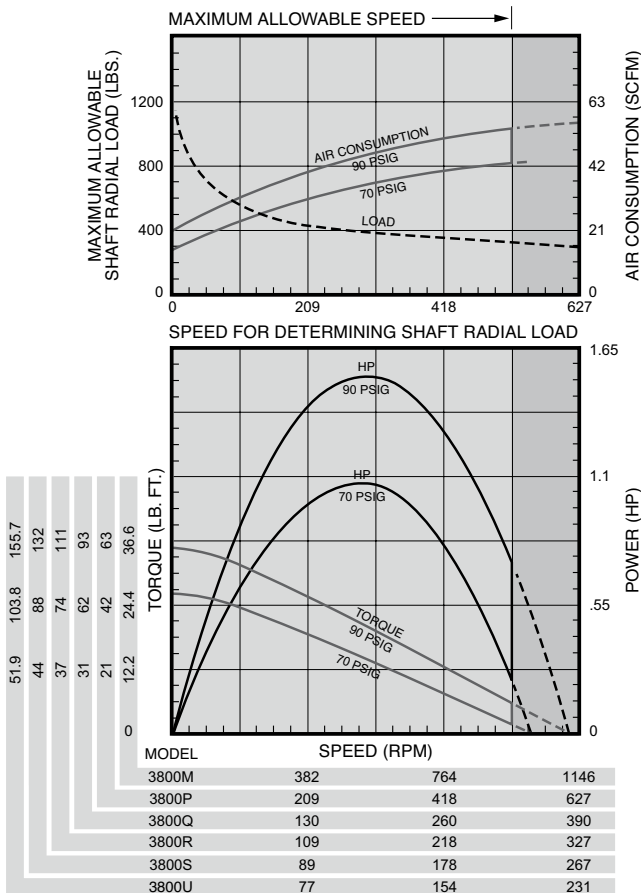

## Series 3800 and 3840 Multi-Vane Air Motors

## Dimensions

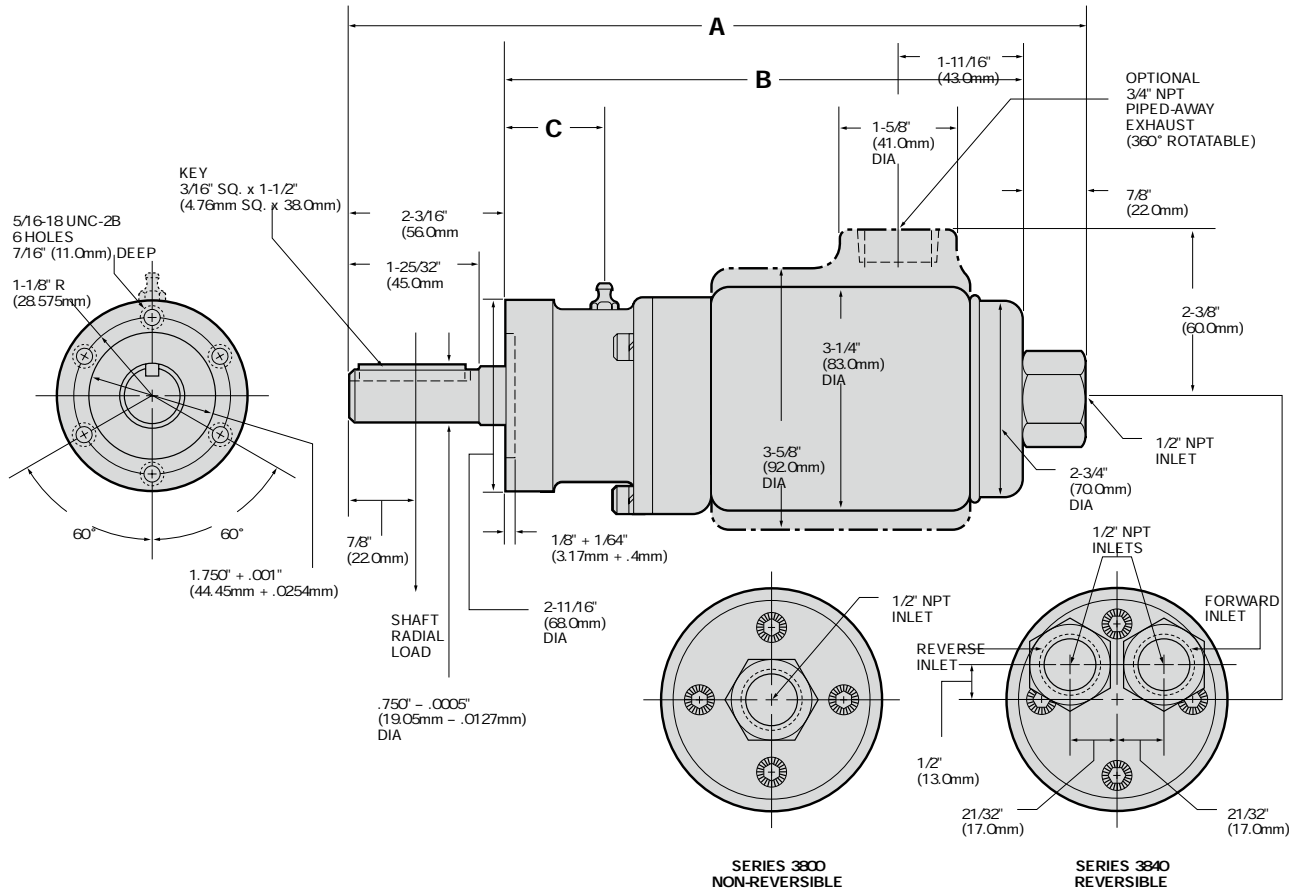

## Dimensions

MODELS	A		B		C	
	in.	mm	in.	mm	in.	mm
3800M, 3840M	10 <sup>1</sup> / <sub>16</sub>	256	7	178	1 <sup>1</sup> / <sub>16</sub>	27
3800P, 3800Q, 3800R, 3800S, 3800U	11 <sup>3</sup> / <sub>16</sub>	299	8 <sup>1</sup> / <sub>16</sub>	221	2 <sup>3</sup> / <sub>16</sub>	56
3840P, 3840Q, 3840R, 3840S, 3840U						

## Equipment Options

Furnished with Cataloged Models	Extra Options
6 Hole Face Mounting	R3800-A123 Exhaust Deflector Assembly with 3/4" Pipe Tap
	*5/8" Square Drive Shaft Shaft Extension 1.25" (31.75mm)

\*To order Motor with Square Drive Shaft, add the suffix "2" to the Model Number. Example: 3840Q2.



## 44-Series Power Motors

### Specifications

MODEL	SPINDLE	R.P.M.		TORQUE				AIR		SOUND LEVEL @FREE SPEED dB(A)	WEIGHT		GEAR REDUCTION
		FREE SPEED	LOAD SPEED @MAX. H.P.	STALL lb. ft. Nm	OUTPUT @MAX. H.P. lb. ft. Nm	CONSUMPTION @FREE SPEED SCFM L/s	SCFM L/s	lbs. kg.					
<b>NON-REVERSIBLE - 2.0 H.P.</b>													
8200-A	7/8" Keyed	275	140	124.00	168.0	75.00	101.6	95.0	44.8	80	18.24	8.20	Double
8201-A	7/8" Keyed	500	255	70.50	95.5	41.00	55.5	95.0	44.8	80	18.24	8.20	Double
8202-A	7/8" Keyed	900	445	40.50	54.9	24.00	32.5	95.0	44.8	80	18.24	8.20	Double
8204-A	7/8" Keyed	3,500	1,740	10.20	13.8	6.00	8.1	95.0	44.8	80	13.82	5.21	Single
8205-A	7/8" Keyed	14,000	7,000	2.85	3.9	1.50	2.0	95.0	44.8	80	13.82	5.21	Single
<b>REVERSIBLE - 1.9 H.P.</b>													
8206-A	7/8" Keyed	275	150	105.00	142.3	66.5	90.1	93.5	44.1	95*	18.24	8.20	Double
8207-A	7/8" Keyed	500	250	60.00	81.3	39.9	54.1	93.5	44.1	95*	18.24	8.20	Double
8208-A	7/8" Keyed	900	450	35.00	47.4	22.2	30.1	93.5	44.1	95*	18.24	8.20	Double
8209-A	7/8" Keyed	2,000	1,000	15.0	20.3	9.97	13.5	93.5	44.1	95*	13.82	5.21	Single
8210-A	7/8" Keyed	3,500	1,800	8.5	11.5	5.54	7.5	93.5	44.1	95*	13.82	5.21	Single
8211-A	7/8" Keyed	14,000	7,000	2.2	3.0	1.43	1.9	93.5	44.1	95*	13.82	5.21	Single

\*R requires installation for reversible motors - shown on page 88.

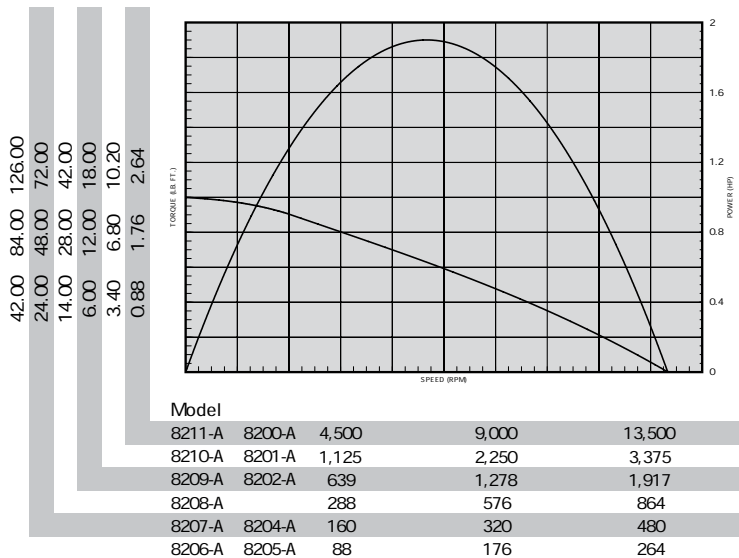

### Standard Equipment

Steel motor housing, flush-type grease fittings at rotation points for gear and bearing lubrication, exhaust manifold rotatable within 360°, and muffler.



### Equipment Options

37892-1 Foot Bracket

NOTE: Gear housing has precision pilot diameter and four mounting holes (5/16"-24) for flange mounting.



### Options for Specified Models

- 41784 3/4" (19.1 mm) Male Square-Drive Adapter for 7/8" (22.23 mm) keyed spindle
- 41512 Throttle & Bracket Assembly for forward-rotation nutsetters.
- 41512-1 Throttle & Bracket Assembly for reversible nutsetters. Includes two 41511 throttles and two 43982-1 Quick-Dump Exhaust Valves.

## 44-Series Power Motors and Mounting Accessory Dimensions

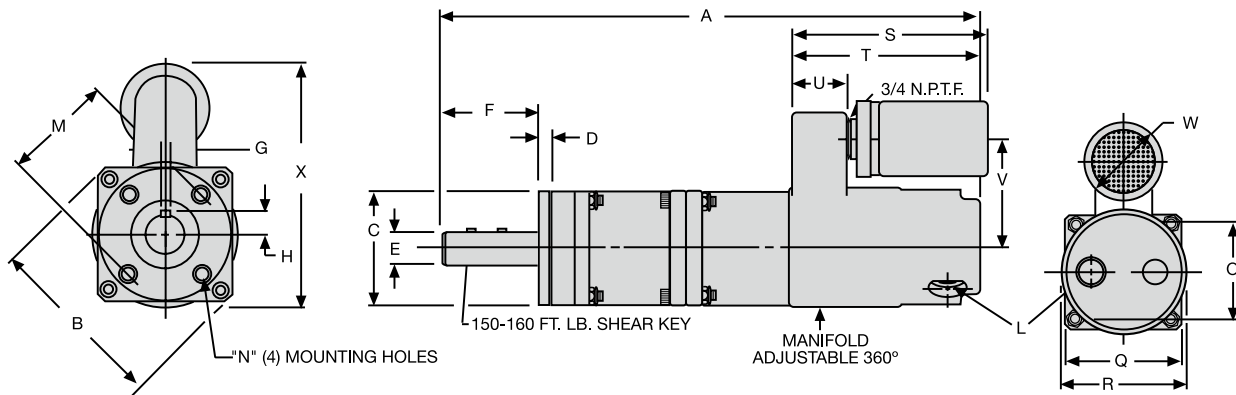

REVERSIBLE ROTATION, DOUBLE REDUCTION SHOWN

Models			Gear Reduction	Dimension A
8203-A	8204-A	8205-A	Single	11-17/64
8209-A	8210-A	8211-A		286 mm
8206-A	8207-A	8208-A	Double	14-1/16
8200-A	8201-A	8202-A		373 mm

Scale	B	C	D	E	F	G	H	L	M	N
Inches	4.090 4.110	2.996 2.998	.369 .374	.8743 .8748	2.483 2.559	.1872 .1875	.528 .531	3/8 NPTF Air Inlet	2.498 2.502	5/16-24 UNF-2B Thread
mm	103.89 104.39	76.10 76.15	9.37 9.50	22.21 22.22	63.07 65.00	4.75 4.76	13.41 13.49		63.45 63.55	

Scale	O	Q	R	S	T	U	V	W	X
Inches	2-1/2	3	3-3/16	5-3/16	5	1-7/16	2-27/32	2	5-7/16
mm	63	76	81	132	127	36	72	51	138

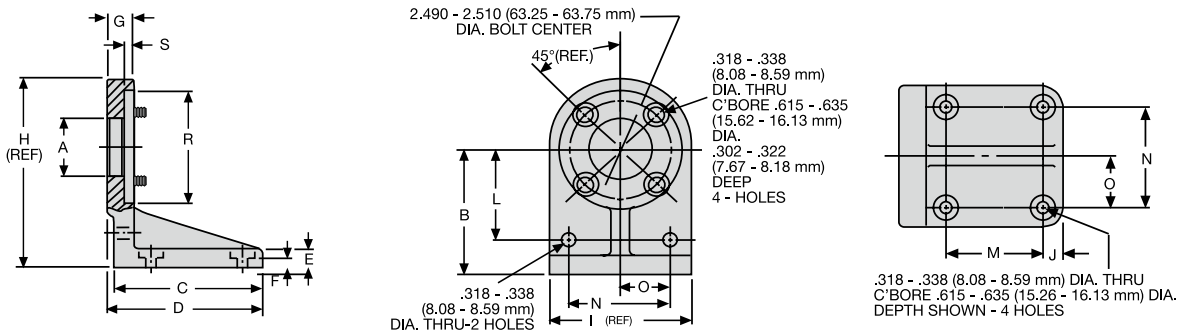

37892-1 FOOT MOUNTING BRACKET

Scale	A	B	C	D	E	F	G	H
Inches	1.490 1.510	3.115 3.135	3.781 3.843	3.968 4.062	.437 .562	.240 .260	.671 .718	4.812 4.937
mm	37.85 38.35	79.12 79.63	96.04 97.61	100.79 103.17	11.10 14.27	6.10 6.60	17.04 18.24	122.22 125.40

Scale	I	J	L	M	N	O	R	S
Inches	3-1/2	.490 .510	2.240 2.260	2.365 2.385	2.490 2.510	1.240 1.260	2.999 3.000	.240 .260
mm	88.90	12.45 12.95	56.90 57.40	60.07 60.58	63.25 63.75	31.50 32.00	76.17 76.20	6.10 6.60

## Series 4800 and 4840 Multi-Vane Air Motors Specifications



Model	Max. Power		Speed at Max. Power	Free Speed▲	Starting Torque		Stall Torque		Air Consumption at Max. Power		Weight	
	hp	kw	rpm	rpm	lb.-ft.	Nm	lb.-ft.	Nm	scfm	m <sup>3</sup> /m	lb.	kg
<b>Non-Reversible</b> Direction of rotation is counterclockwise when facing the shaft.												
4800D	3.8	2.83	5250	9850	5.8	7.8	7.7	10.4	98	2.77	15%	6.92
4800K	3.7	2.76	821	1538	35.3	47.8	47	63.7	95	2.69	15%	6.92
4800M	3.7	2.76	560	1050	51	69.2	69	93.6	95	2.69	15%	6.92
4800N	3.7	2.76	387	726	75	102	100	136	95	2.69	15%	6.92
4800P	3.5	2.61	260	510	98	133	131	178	95	2.69	19%	8.96
4800Q	3.5	2.61	194	375	129	175	173	235	95	2.69	19%	8.96
4800S	3.5	2.61	146	275	178	241	238	323	95	2.69	19%	8.96
4800U	3.5	2.61	97	185	265	359	354	480	95	2.69	19%	8.96
<b>Reversible</b>												
4840D	3.3	2.46	4550	9100	5.2	7.0	6.9	9.4	95	2.69	15%	6.92
4840K	3.2	2.39	711	1429	32	43.4	42.7	57.9	95	2.69	15%	6.92
4840M	3.2	2.39	485	975	47.3	64.0	63.0	85.4	95	2.69	15%	6.92
4840N	3.2	2.39	336	675	67.7	91.7	90.2	122	95	2.69	15%	6.92
4840P	3	2.24	228	475	93	126	125	170	95	2.69	20%	9.13
4840Q	3	2.24	167	350	123	167	165	224	95	2.69	20%	9.13
4840S	3	2.24	125	255	161	218	215	292	95	2.69	20%	9.13
4840U	3	2.24	83	170	225	305	300	407	95	2.69	20%	9.13

▲ ALL models must be operated with sufficient load to prevent speed from exceeding maximum allowable speed shown on performance curve. Performance figures are at 90 psig (620 kPa) air pressure.

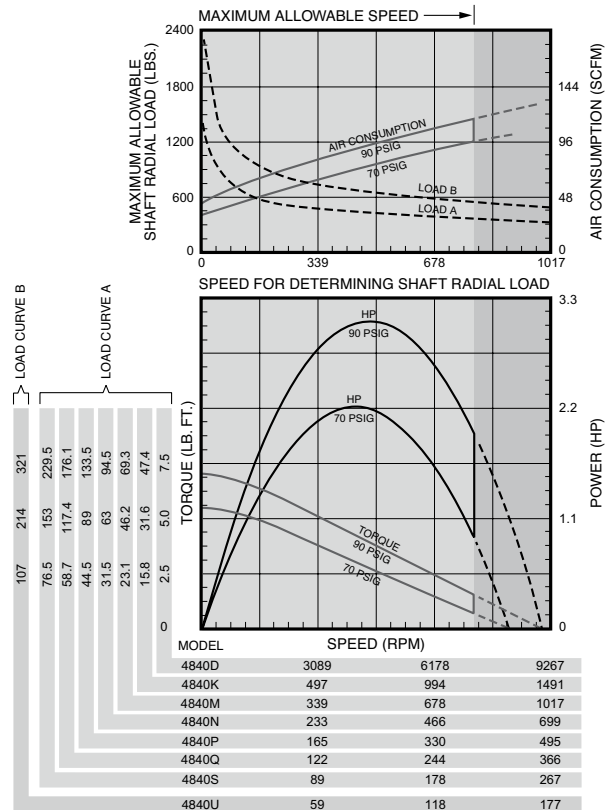
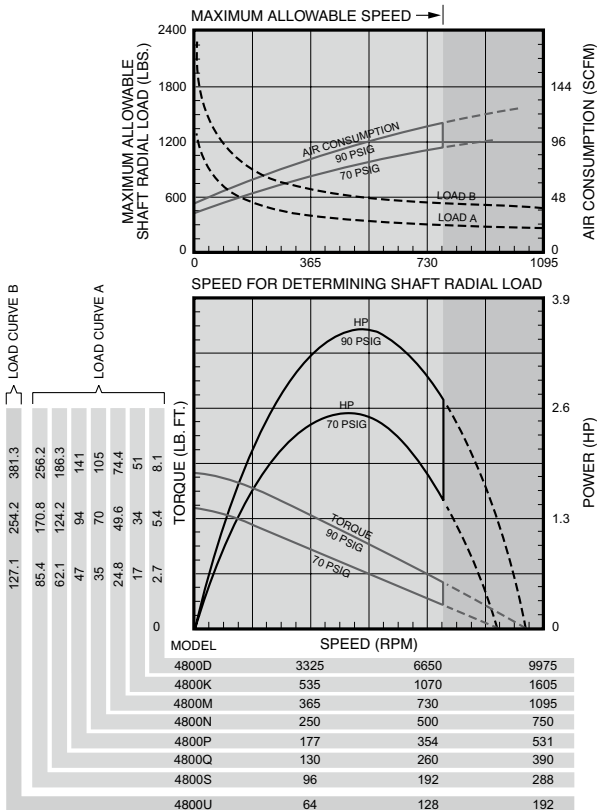

## Series 4800 and 4840 Multi-Vane Air Motors

### Dimensions

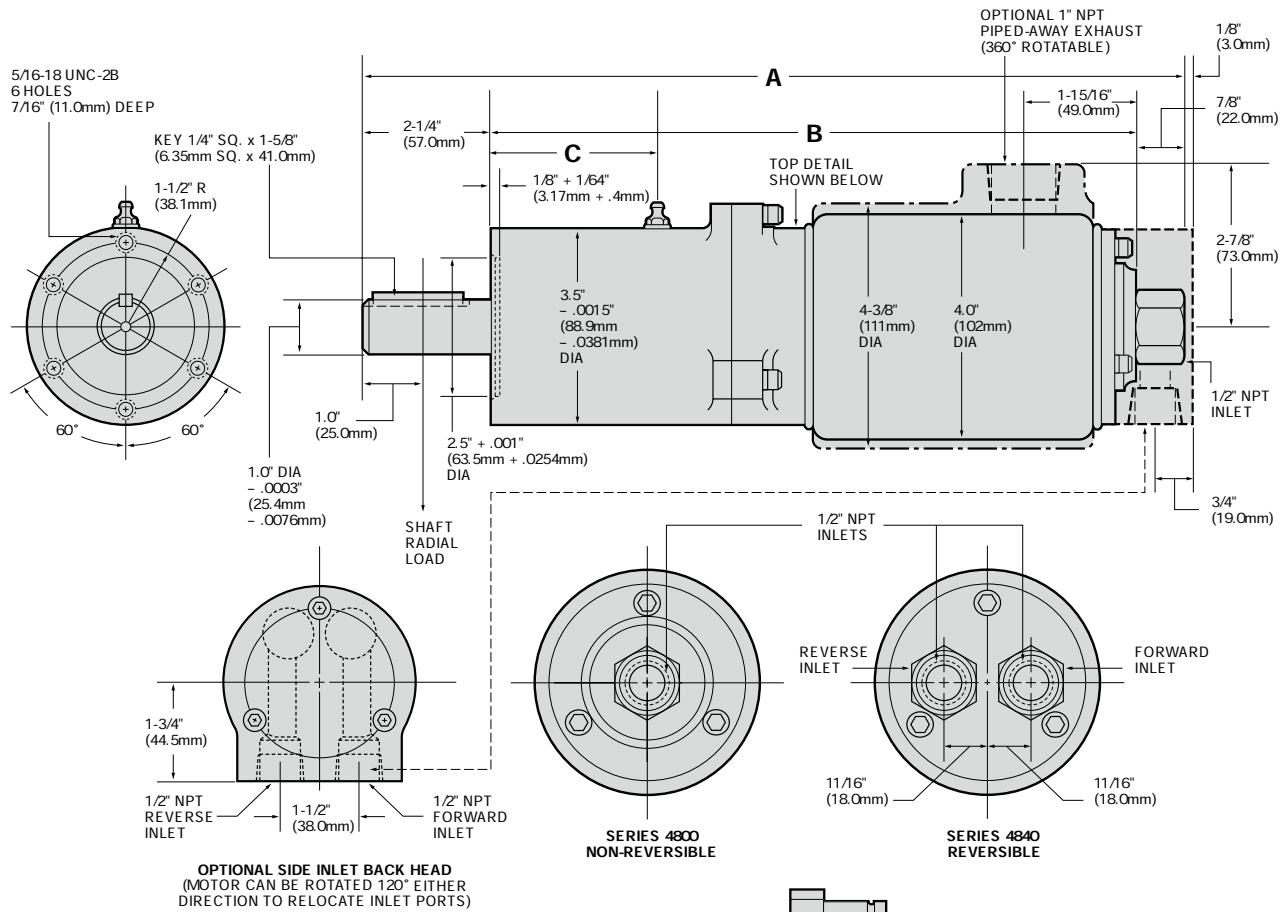

### Dimensions

MODELS	A		B		C	
	in.	mm	in.	mm	in.	mm
4800D, 4800K, 4800M, 4800N 4840D, 4840K, 4840M, 4840N	12 1/2	308	9	229	2 9/32	23
4800P, 4800Q, 4800S, 4800U 4840P, 4840Q, 4840S, 4840U	14 1/2	368	11	289	2	73

### Equipment Options

Furnished with Cataloged Models	Extra Options
6 Hole Face Mounting	R4800-A123 Exhaust Deflector Assembly with 1" Pipe Tap ** R4901-102 Side Inlet Backhead Requires (3) 518-104 Screws
	* 5/8" Square Drive Shaft on Gear Ratio: M Shaft Extension 1.38" (35.5mm) * 3/4" Square Drive Shaft on Gear Ratios: P, Q, S, U Shaft Extension 1.47" (37.44mm)

\*To order Motor with Square Drive Shaft, add the suffix "2" to the Model Number. Example: 4840Q2.

\*\*Contact Ingersoll Rand for Model Number with these options.

# Spur Gear, Multi-Vane Motors

## Series 17RA, 17RB, 34RA and 34RB

### Specifications



Model	Max. Power		Speed at Max. Power	Free Speed▲	Starting Torque		Stall Torque		Air Consumption at Max. Power		Weight	
	hp	kw	rpm		rpm	lb.-ft.	Nm	lb.-ft.	Nm	scfm	m³/m	lb.
<b>Reversible</b>												
17RA005	2.3	1.72	562	1110	24	32.5	37	50.2	103	2.92	40	18.1
17RA008	2.3	1.72	383	760	35	47.5	54.5	73.9	103	2.92	40	18.1
17RA011	2.3	1.72	254	505	53	71.9	82	111	103	2.92	40	18.1
17RA014	2.3	1.72	201	400	67	91	104	141	103	2.92	40	18.1
17RA017	2.3	1.72	169	335	80	109	124	168	103	2.92	40	18.1
17RA022	2.3	1.72	129	255	105	142	163	221	103	2.92	40	18.1
17RB029	2.2	1.64	97	187	120	163	201	273	100	2.83	72	32.7
17RB036	2.2	1.64	79	152	148	201	248	336	100	2.83	72	32.7
17RB045	2.2	1.64	62	121	187	254	312	423	100	2.83	72	32.7
17RB078	2.2	1.64	36	69	327	443	545	739	100	2.83	72	32.7
34RA005	4.1	3.06	560	1080	41	60	69	93.6	183	5.18	43	19.5
34RA008	4.1	3.06	385	740	65	88	101	137	183	5.18	43	19.5
34RA011	4.1	3.06	255	490	98	133	152	206	183	5.18	43	19.5
34RA014	4.1	3.06	201	390	124	168	192	260	183	5.18	43	19.5
34RA017	4.1	3.06	168	325	148	201	229	311	183	5.18	43	19.5
34RA022	4.1	3.06	128	245	195	264	301	408	183	5.18	43	19.5
34RB029	4	2.98	99	187	224	304	374	507	180	5.1	75	34
34RB036	4	2.98	80	152	277	376	462	627	180	5.1	75	34
34RB045	4	2.98	63	121	348	472	581	788	180	5.1	75	34
34RB078	4	2.98	36	69	606	822	1010	1370	180	5.1	75	34

▲ ALL models must be operated with sufficient load to prevent speed from exceeding maximum allowable speed shown on performance curve. Performance figures are at 90 psig (620 kPa) air pressure.

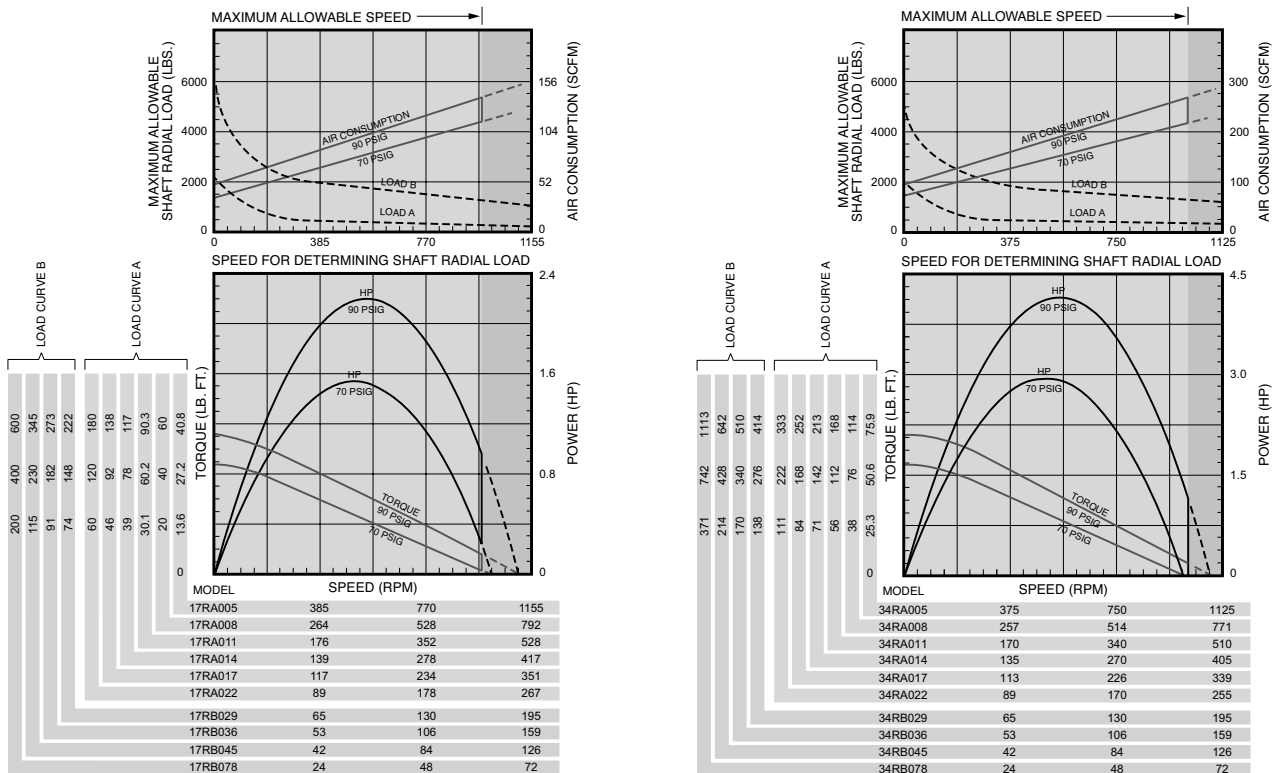



## Series 17RA, 17RB, 34RA, and 34RB Multi-Vane Air Motors

### Dimensions

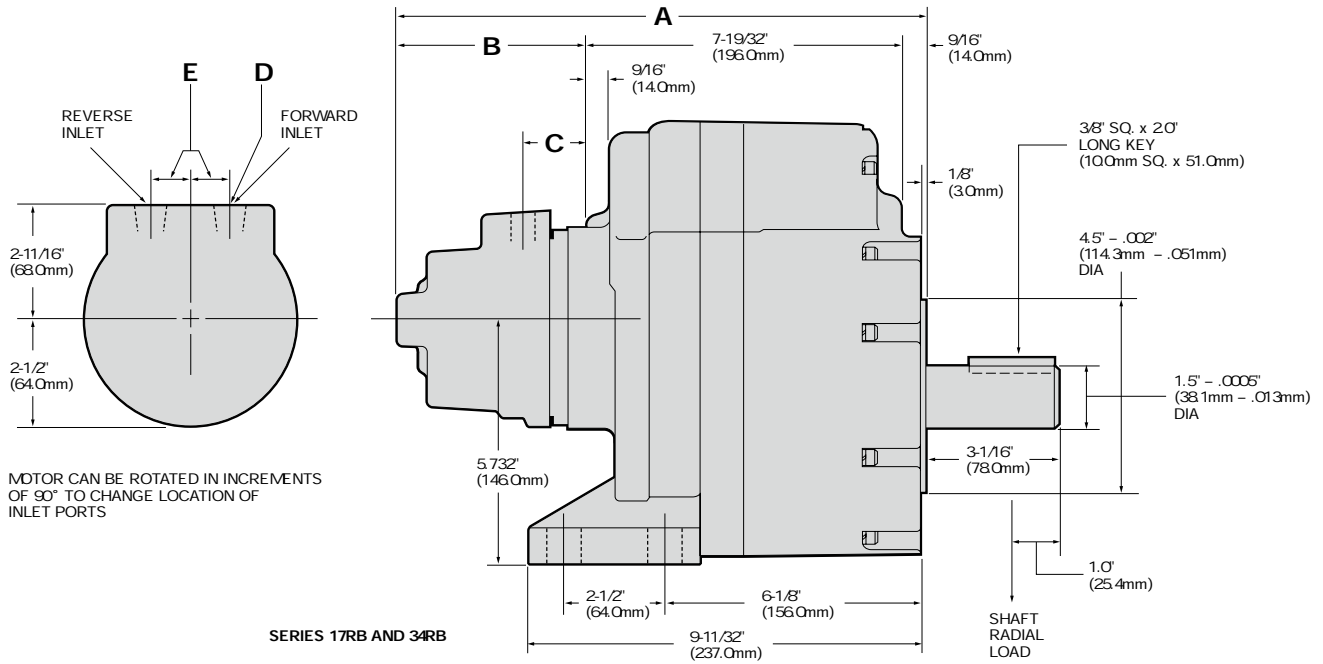

### Dimensions

SERIES	A		B		C		D	E	
	in.	mm	in.	mm	in.	mm	NPT	in.	mm
17RB	13 1/8	332	4 29/32	125	2 1/8	56	3/8"	7/8	22
34RB	14 13/16	376	6 29/32	169	2 1/2	58	1/2"	1 1/8	30

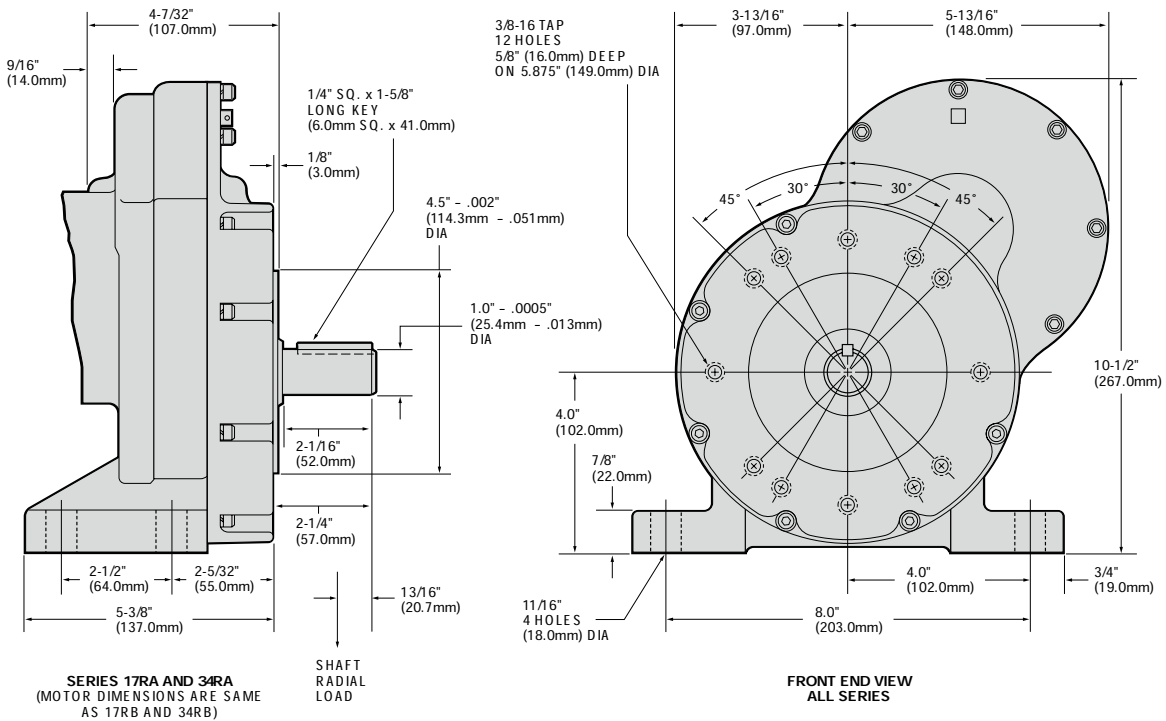

## Series 48RA and 48RB Multi-Vane Air Motors

### Specifications

Model	Max. Power		Speed at Max. Power	Free Speed▲	Starting Torque		Stall Torque		Air Consumption at Max. Power		Weight	
	hp	kw	rpm	rpm	lb.-ft.	Nm	lb.-ft.	Nm	scfm	m <sup>3</sup> /m	lb.	kg
<b>Reversible</b>												
48RA005	3.1	2.31	930	1690	26	35.3	35	47.5	95	2.69	44	20
48RA008	3.1	2.31	638	1160	38	51.5	51.5	69.8	95	2.69	44	20
48RA011	3.1	2.31	423	772	57	77.3	77.5	105	95	2.69	44	20
48RA014	3.1	2.31	332	612	72	97.6	98	133	95	2.69	44	20
48RA017	3.1	2.31	278	511	86	117	117	159	95	2.69	44	20
48RA022	3.1	2.31	213	390	113	153	154	209	95	2.69	44	20
48RB029	3	2.24	162	292	135	183	189	256	90	2.55	75	34
48RB036	3	2.24	131	236	167	227	234	317	90	2.55	75	34
48RB045	3	2.24	105	188	209	283	295	400	90	2.55	75	34
48RB078	3	2.24	60	108	364	494	513	696	90	2.55	75	34

▲ ALL models must be operated with sufficient load to prevent speed from exceeding maximum allowable speed shown on performance curve. Performance figures are at 90 psig (620 kPa) air pressure.

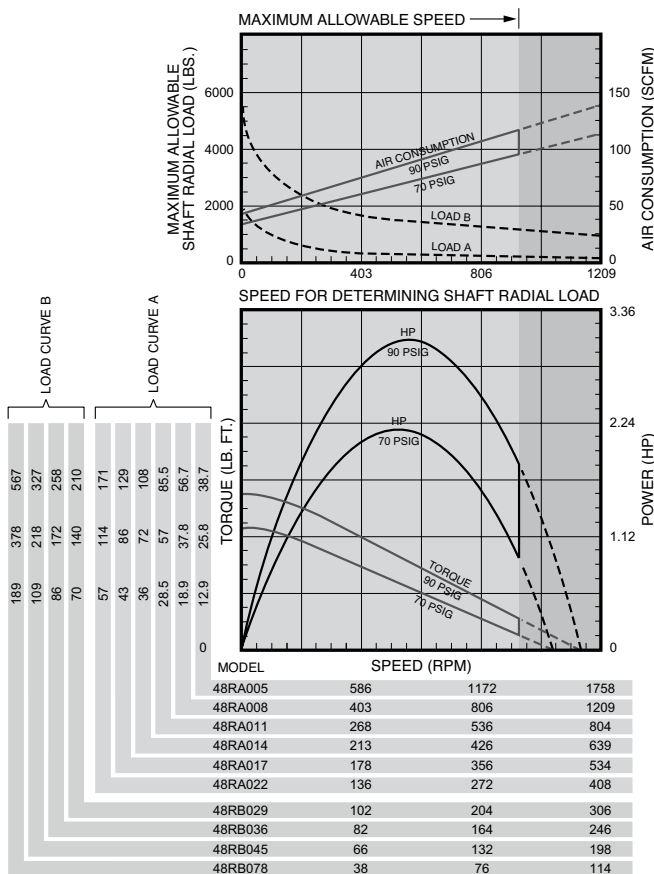

### Equipment Options

Furnished with Cataloged Models	Standard Options
Side Inlet Backhead	R4840-102 Rear Inlet Backhead

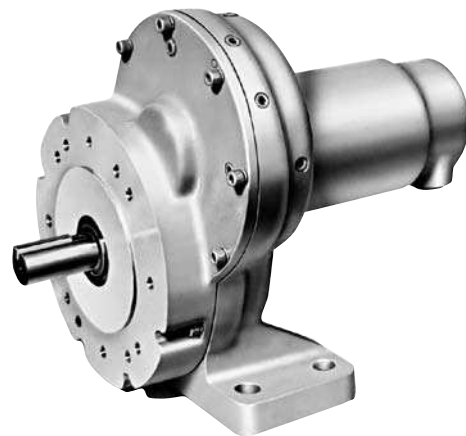

## Series 48RA and 48RB Multi-Vane Air Motors

### Dimensions

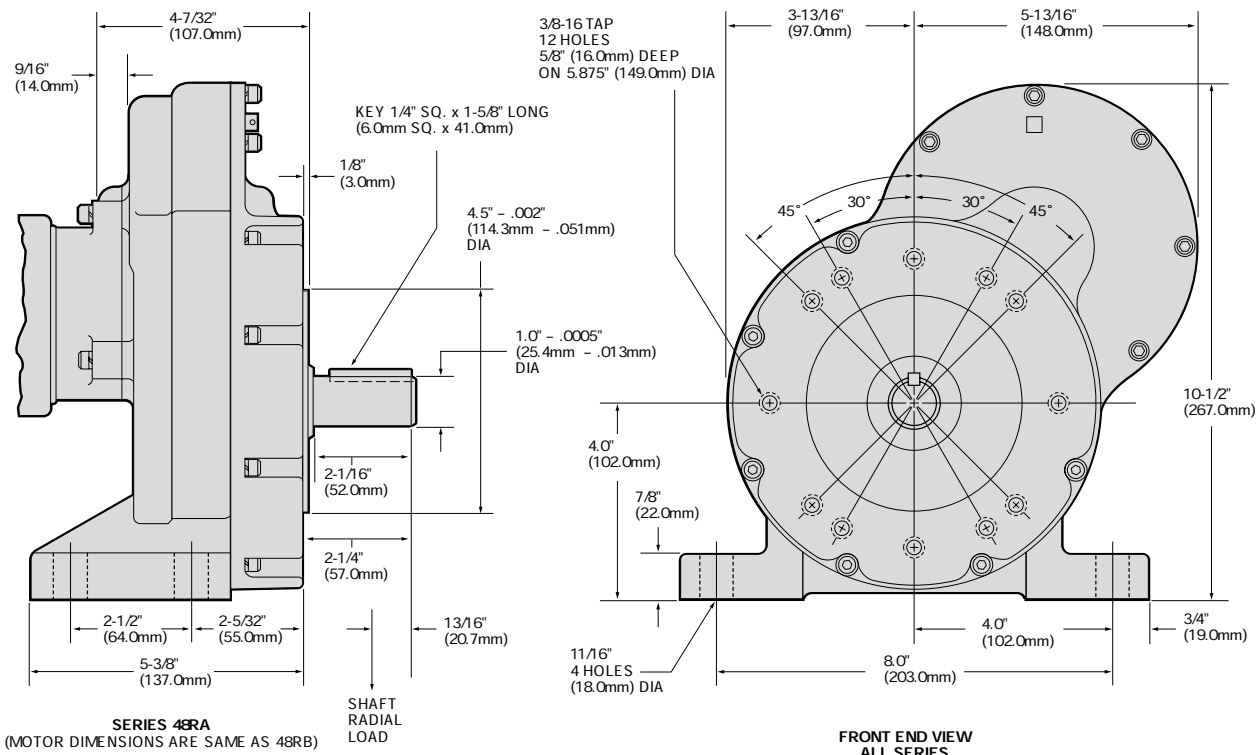
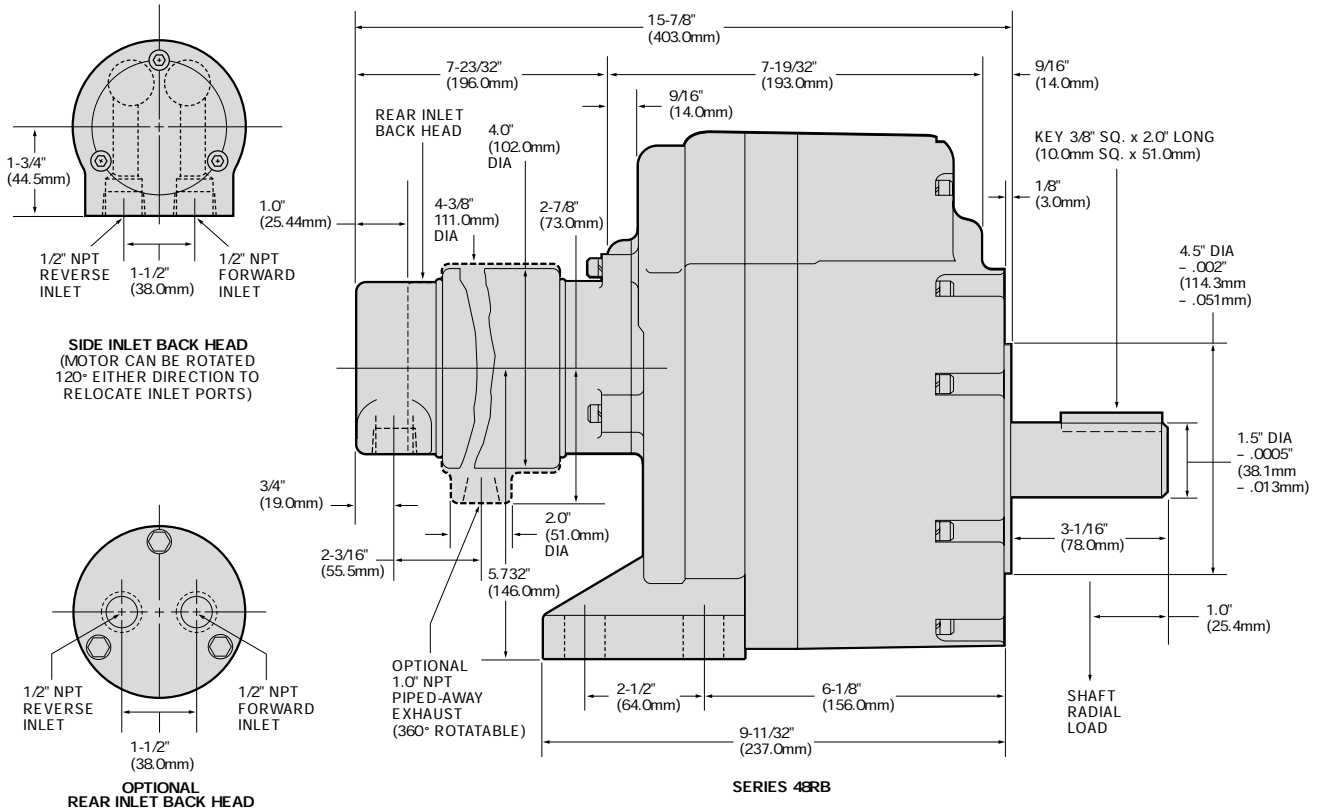

## Series 92RA and 92RB Multi-Vane Air Motors

### Specifications

Model	Max. Power		Speed at Max. Power	Free Speed ▲	Starting Torque		Stall Torque		Air Consumption at Max. Power		Weight	
	hp	kw	rpm	rpm	lb.-ft.	Nm	lb.-ft.	Nm	scfm	m <sup>3</sup> /m	lb.	kg
<b>Reversible</b>												
92RA005	8.15	6.08	910	1390	56	75.9	75	102	230	6.51	46	20.9
92RA008	8.15	6.08	620	1296	80	109	109	148	230	6.51	46	20.9
92RA011	8.15	6.08	415	852	120	163	164.5	223	230	6.51	46	20.9
92RA014	8.15	6.08	327	682	152	206	208	282	230	6.51	46	20.9
92RA017	8.15	6.08	274	571	180	244	248	336	230	6.51	46	20.9
92RA022	8.15	6.08	209	435	235	319	326	442	230	6.51	46	20.9
92RB029	7.9	5.89	160	327	280	380	402	545	225	6.37	78	35.4
92RB036	7.9	5.89	130	264	345	468	497	674	225	6.37	78	35.4
92RB045	7.9	5.89	103	210	440	597	626	849	225	6.37	78	35.4
92RB078	7.9	5.89	59	120	770	1044	1090	1478	225	6.37	78	35.4

▲ ALL models must be operated with sufficient load to prevent speed from exceeding maximum allowable speed shown on performance curve. Performance figures are at 90 psig (620 kPa) air pressure.

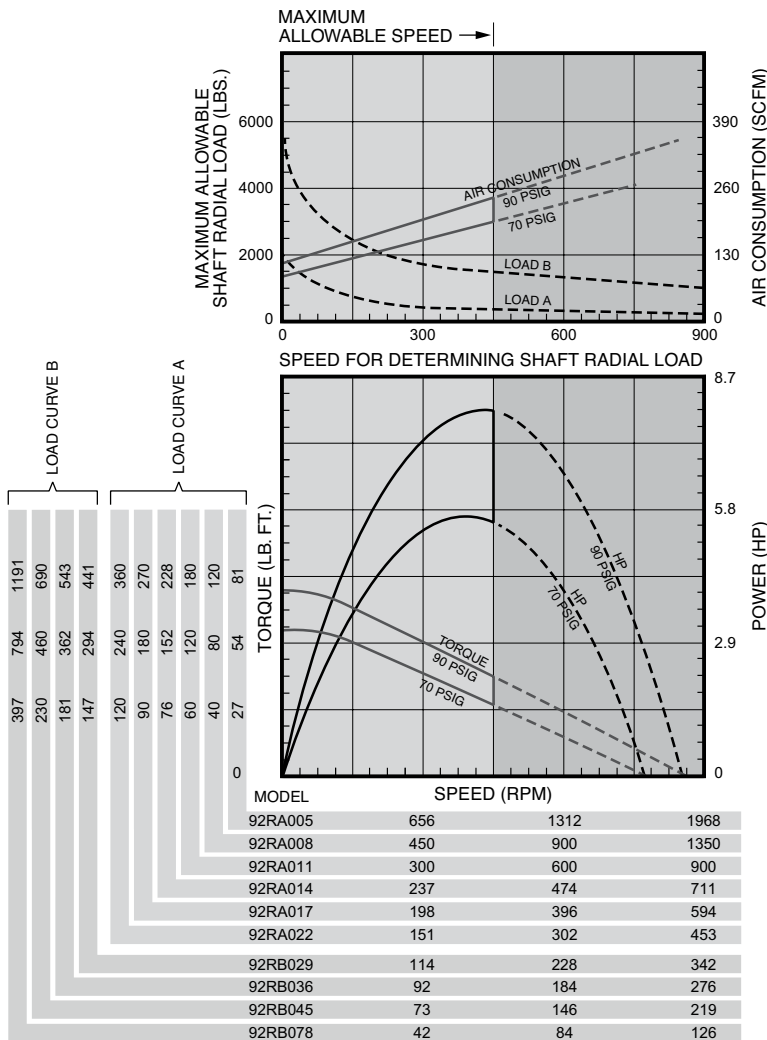

## Series 92RA and 92RB Multi-Vane Air Motors

### Dimensions

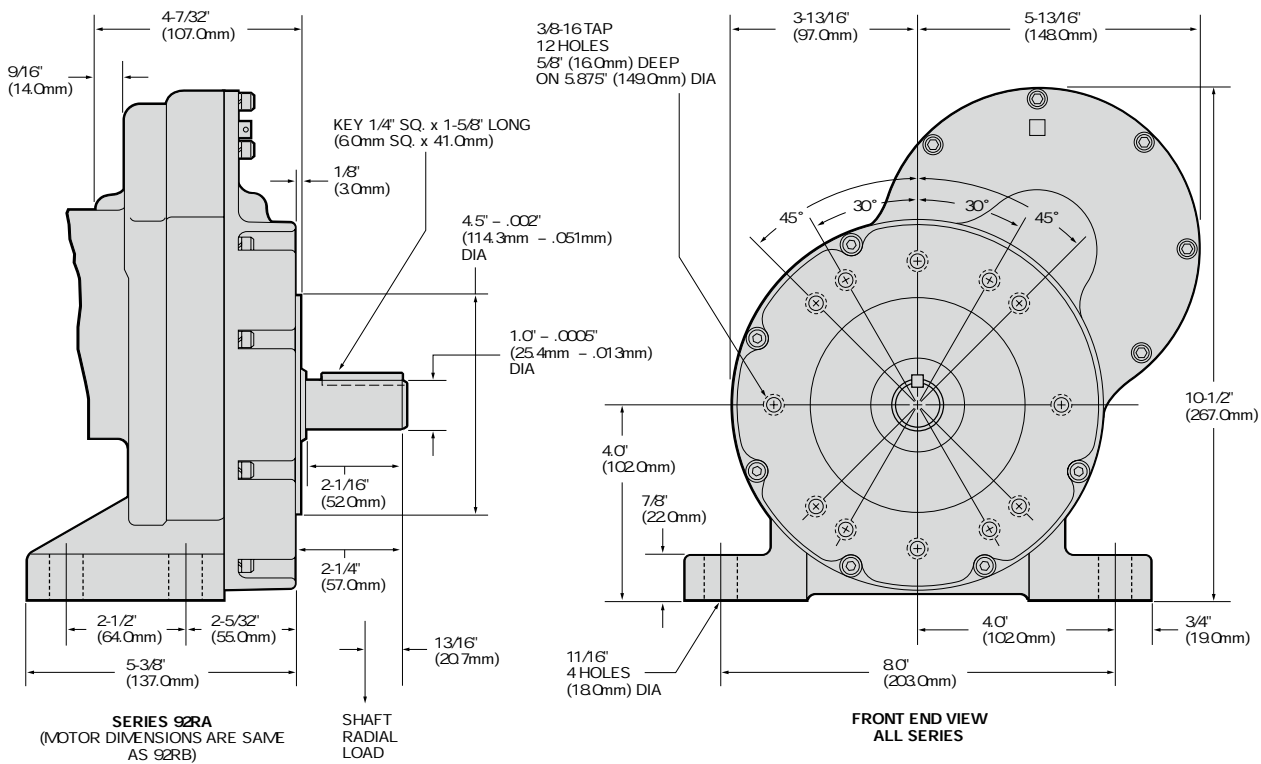
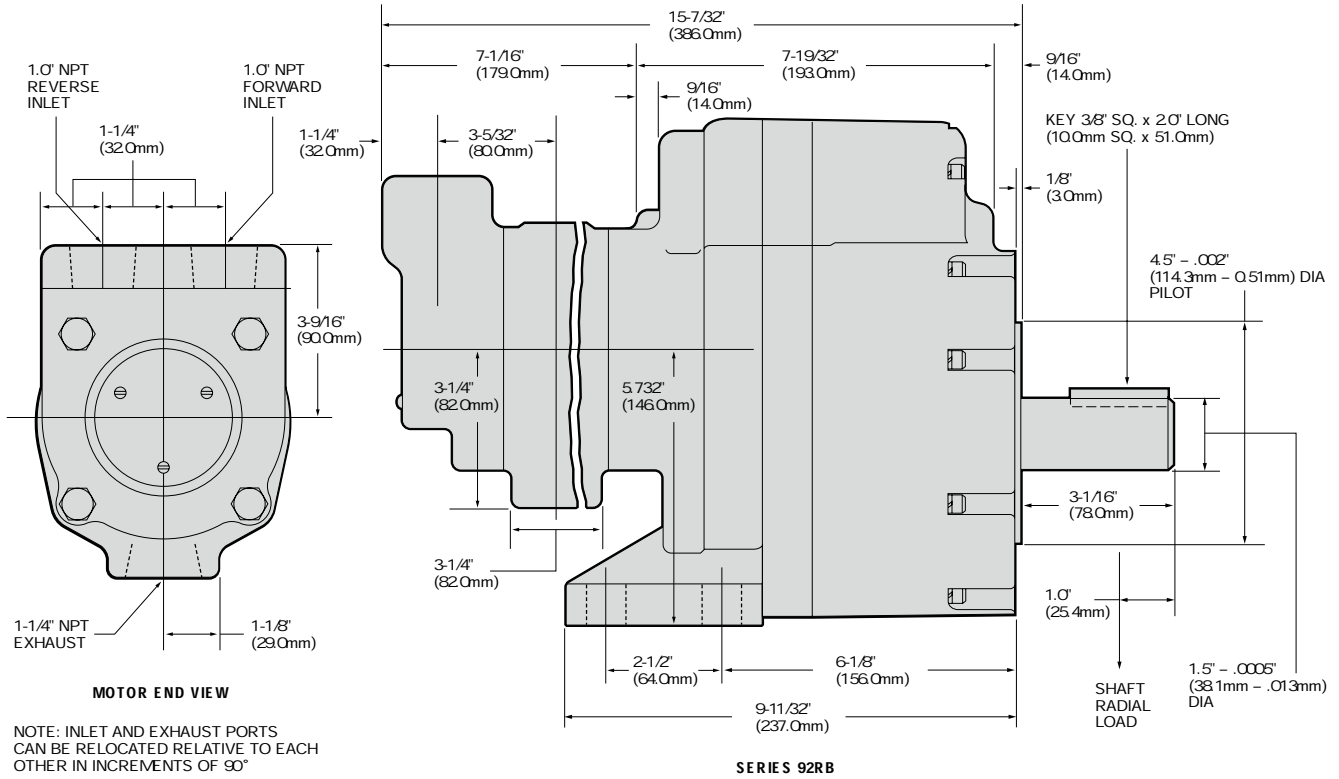



## Series 92RM and 992RM Multi-Vane Air Motors Specifications



Model	Max. Power		Speed at Max. Power	Free Speed▲	Starting Torque		Stall Torque		Air Consumption at Max. Power		Weight	
	hp	kw	rpm	rpm	lb.-ft.	Nm	lb.-ft.	Nm	scfm	m <sup>3</sup> /m	lb.	kg
<b>Non-Reversible</b> Direction of rotation is counterclockwise when facing the shaft.												
92RM1	9.9	7.38	2095	3980	33	44.7	45	61	240	6.79	24¼	11
92RM2	9.9	7.38	2095	3980	33	44.7	45	61	240	6.79	24¼	11
<b>Reversible</b>												
992RM1	8.15	6.08	1730	3600	28.7	38.9	39	52.9	230	6.51	25¼	11.3

▲ ALL models must be operated with sufficient load to prevent speed from exceeding maximum allowable speed shown on performance curve. Performance figures are at 90 psig (620 kPa) air pressure.

Direction of rotation of Model 92RM1 is clockwise, and of Model 92RM2 is counter clockwise when facing the shaft end of the motor.

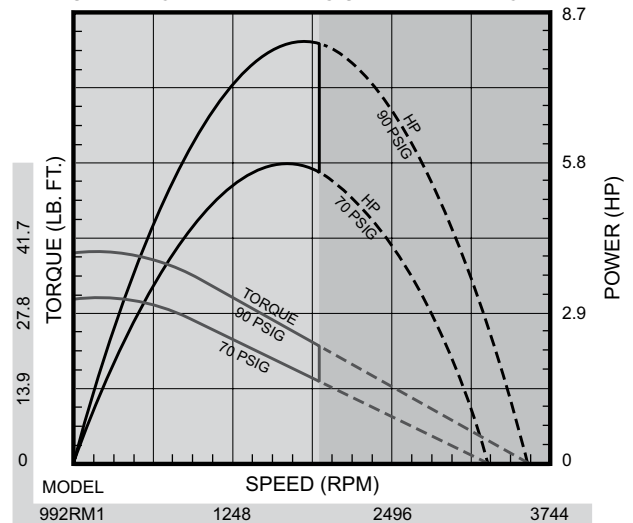
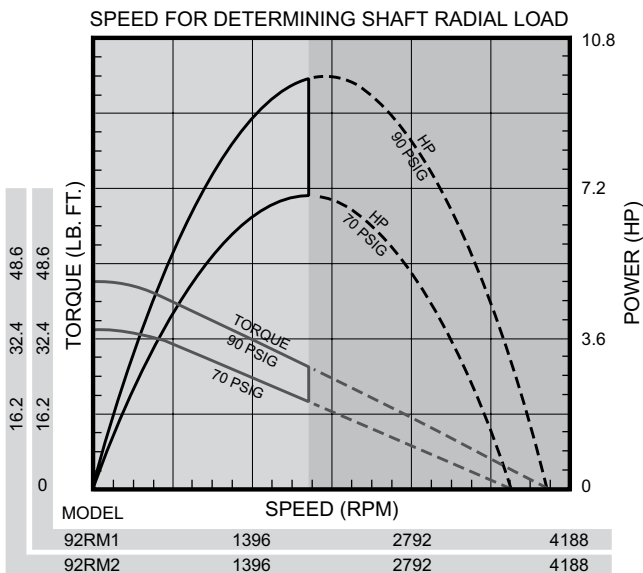
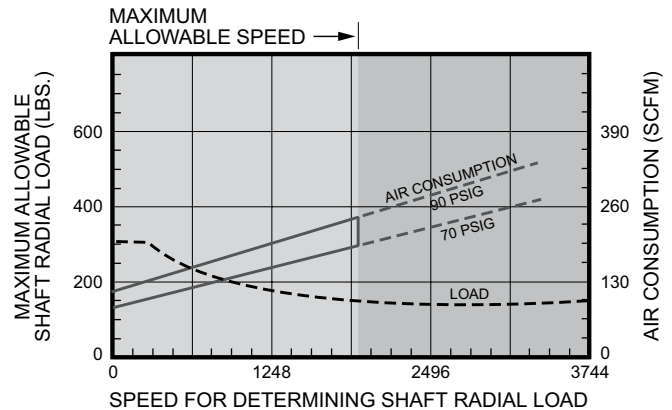
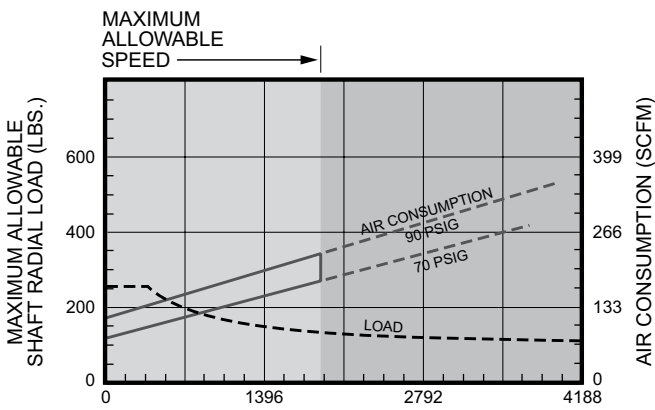

## Series 92RM and 992RM Multi-Vane Air Motors

### Dimensions

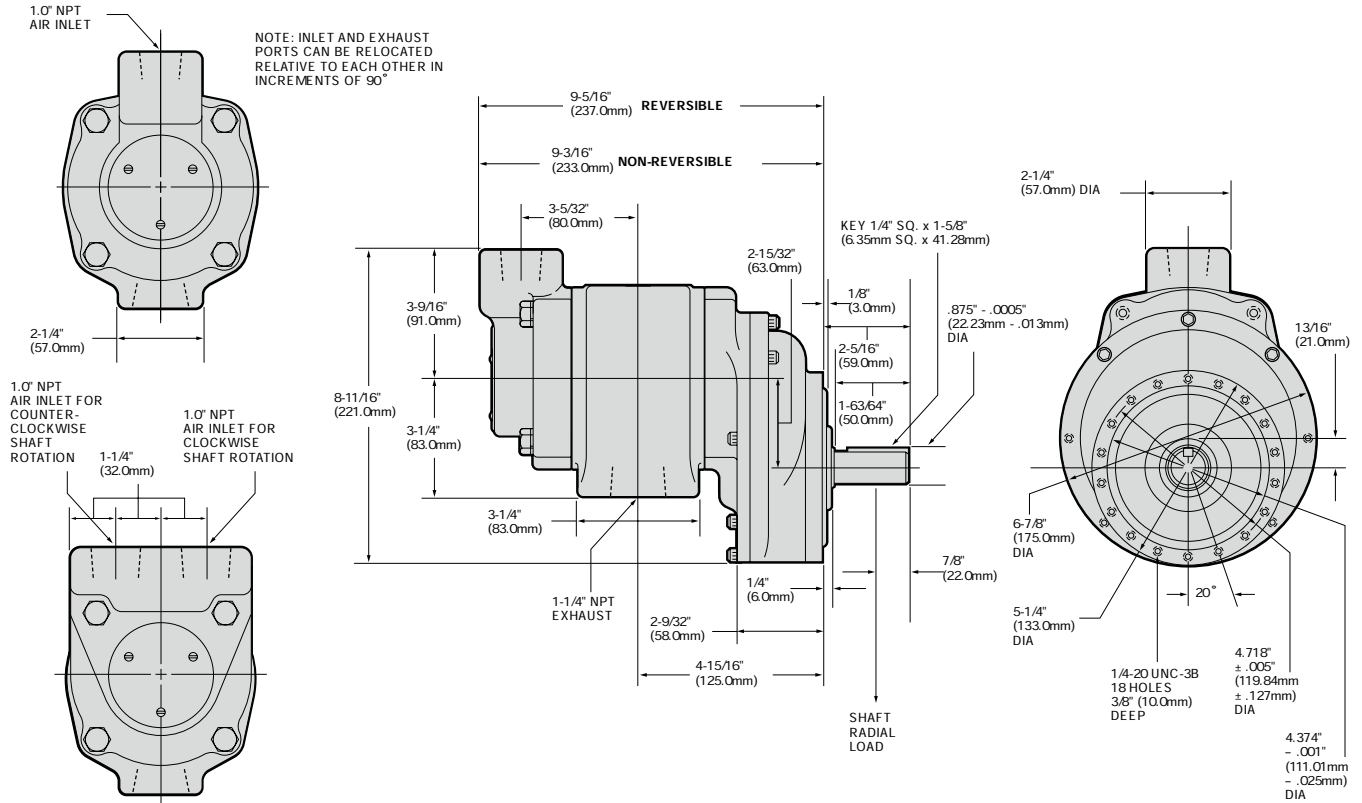

# Direct Drive Multi-Vane Motors

## Series MVA and MOV0

### Specifications

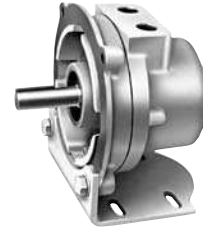

Model*	Max. Power		Speed at Max. Power	Free Speed▲	Starting Torque		Stall Torque		Air Consumption at Max. Power		Weight	
	hp	kw	rpm	rpm	lb.-ft.	Nm	lb.-ft.	Nm	scfm	m <sup>3</sup> /m	lb.	kg
<b>Reversible</b>												
MVA017A	1.93	1.44	2800	5450	4.5	6.1	7	9.5	76	2.15	12½	5.67
MVA017B	1.93	1.44	2800	5450	4.5	6.1	7	9.5	76	2.15	12½	5.67
MVA034A	4.15	3.09	3000	6250	8.3	11.3	12.8	17.4	181	5.12	16½	7.48
MVA034B	4.15	3.09	3000	6250	8.3	11.3	12.8	17.4	181	5.12	16½	7.48
MOV005AA	.75	.56	3300	6800	1.65	2.2	2.2	2.98	30	.84	6½	2.95
MOV075AA	10.5	7.8	2600	5600	22.5	30.5	30	40.7	260	7.36	64	29

▲ ALL models must be operated with sufficient load to prevent speed from exceeding maximum allowable speed shown on performance curve. Performance figures are at 90 psig (620 kPa) air pressure.

\* "A" suffix denotes foot mount model, "B" suffix denotes flange mount models.

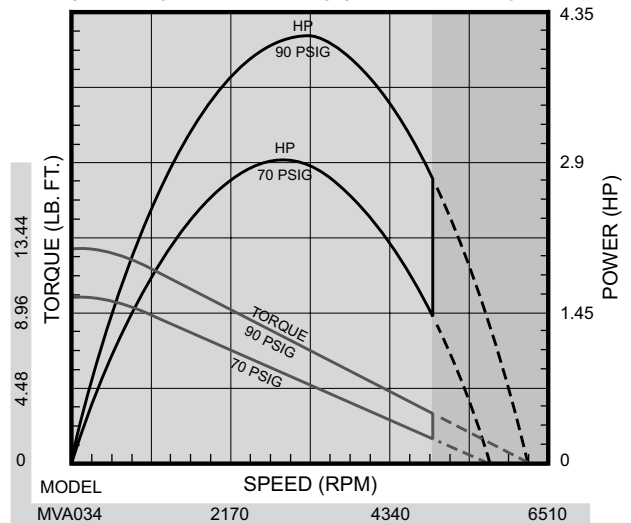
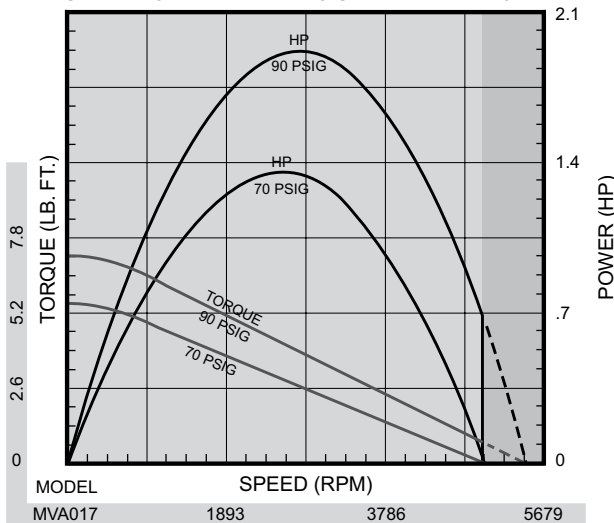
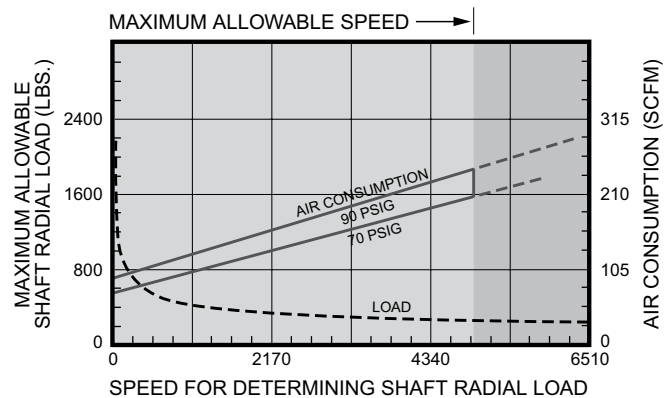
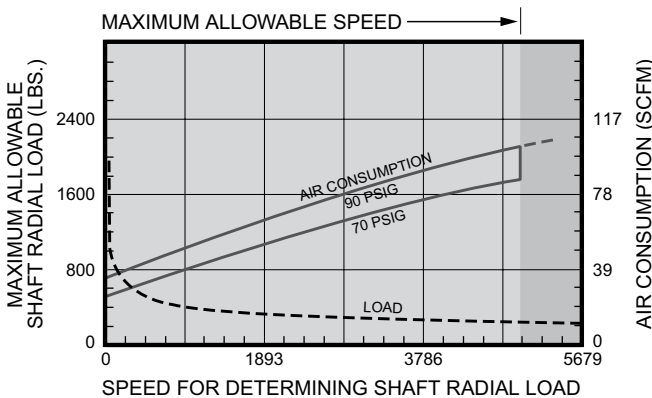

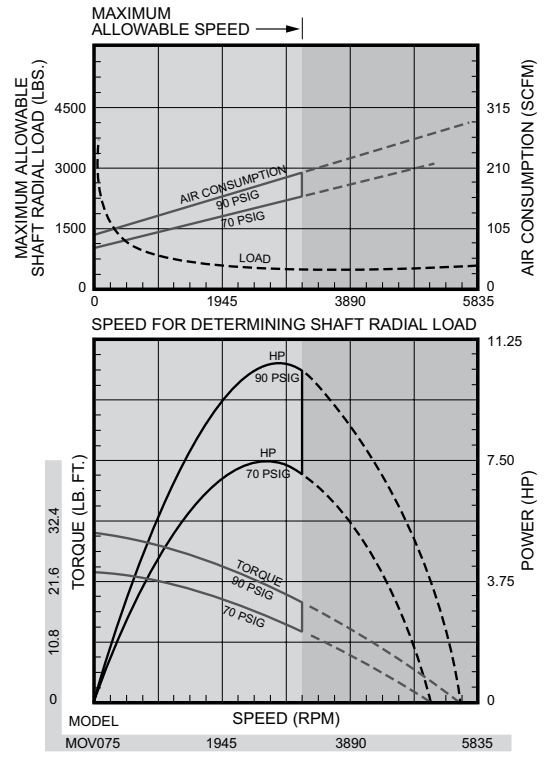
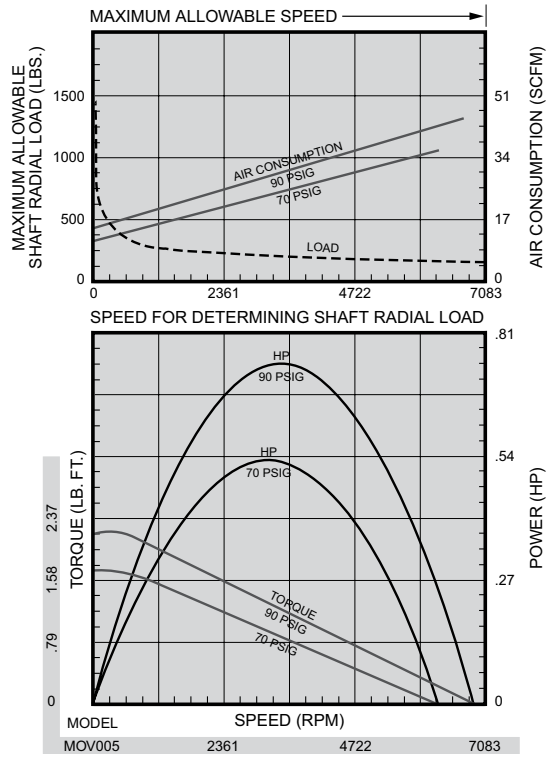

**Series MVA Dimensions**

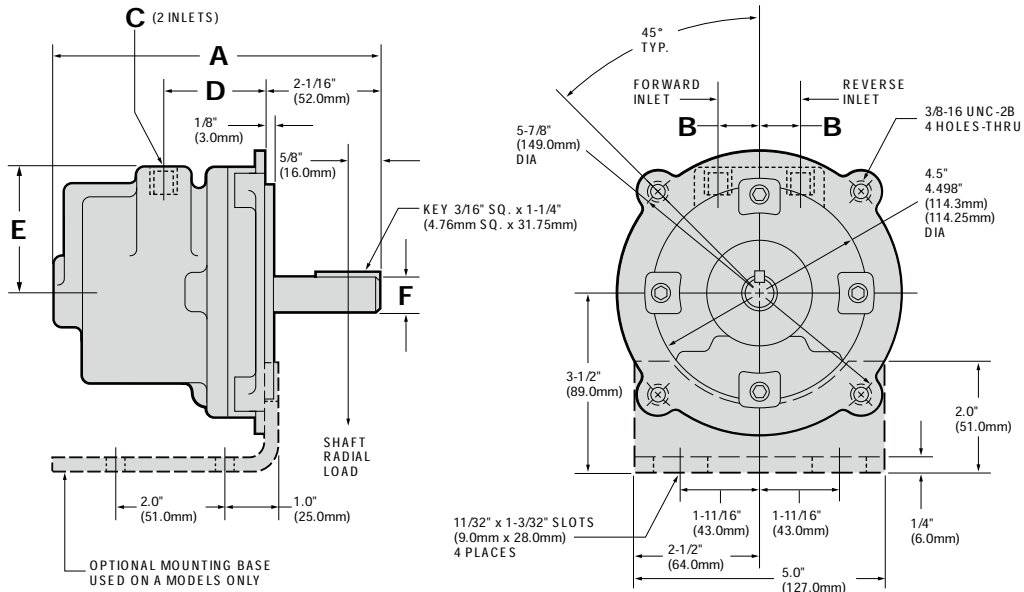

**Dimensions**

SERIES	A		B		C NPT	D		E		F DIA.	
	in.	mm	in.	mm		in.	mm	in.	mm	in.	mm
MVA017	6 <sup>1</sup> / <sub>16</sub>	170	7 <sup>1</sup> / <sub>16</sub>	22	3/8"	1 <sup>1</sup> / <sub>16</sub>	48	2 <sup>1</sup> / <sub>16</sub>	64	.6250 .6245	15.88 15.86
MVA034	8 <sup>1</sup> / <sub>16</sub>	214	1 <sup>1</sup> / <sub>16</sub>	30	1/2"	2	51	2 <sup>1</sup> / <sub>16</sub>	67	.8750 .8745	22.23 22.21

**Model MOV005AA Dimensions**

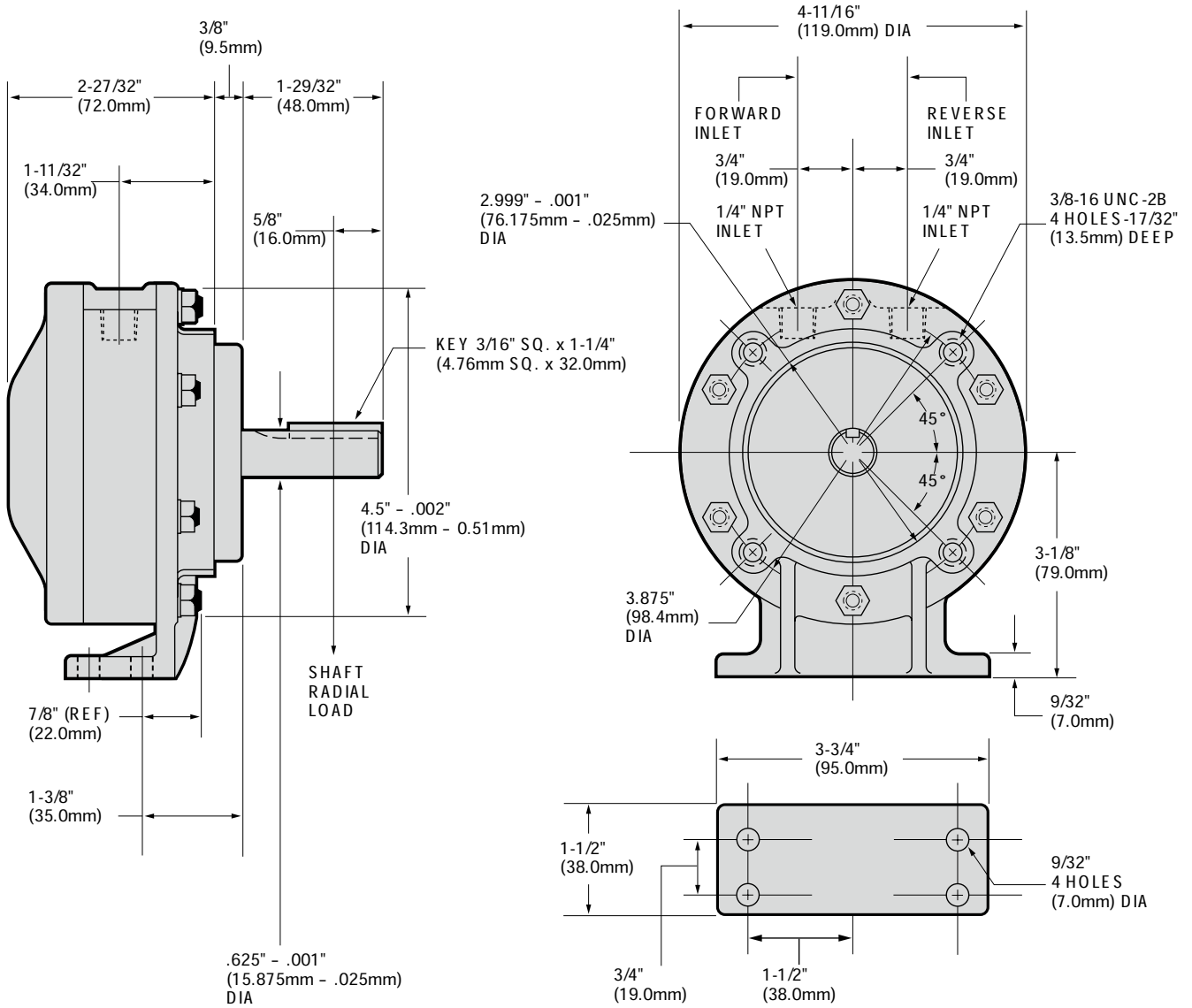



## Model MOV075AA Dimensions

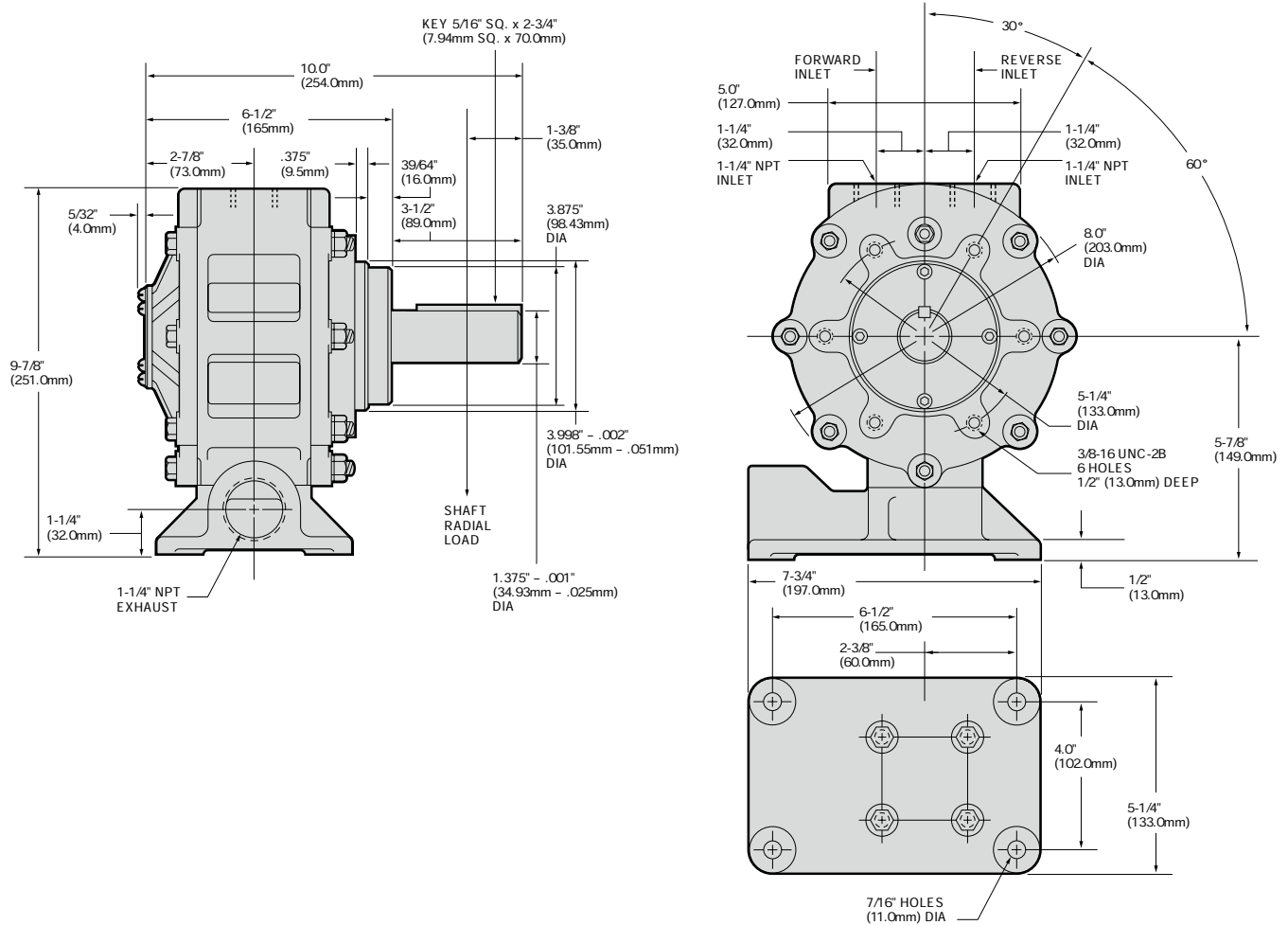

## Equipment Options

Models	Furnished with Cataloged Models	Standard Options
MVA017A	*Foot Mounting	
MVA017B	NEMA C Face 56C Frame Size	MVA008-K4 Mounting Foot Kit
MVA034A	**Foot Mounting	MOV010AA-674 Muffler
MVA034B	NEMA C Face 182C Frame Size	MVA008-K4 Mounting Foot Kit MOV010AA-674 Muffler
MOV005AA	Foot/4 Hole Face Mounting	MRV015-AC 980 Muffler
MOV075AA	Foot/6 Hole Face Mounting	150BM-A674 Muffler

\* Removal of Foot Mounting results in Motor having NEMA C Face Mounting, 56C Frame Size.

\*\* Removal of Foot Mounting results in Motor having NEMA C Face Mounting, 182C Frame Size.

## MRV Series Lube Free Multi Vane Air Motors Specifications



Series	Max Power		Speed at Max Power	Free Speed	Starting Torque		Stall Torque		Air Consumption at Max. Power		Weight	
	hp	kw	rpm	rpm	lb.-ft.	Nm	lb.-ft.	Nm	scfm	m <sup>3</sup> /m	lb.	kg
<b>MRV003A</b> MRV003C	0.33	0.25	7600	15,200	0.29	0.39	0.38	0.52	17	0.5	1½	0.6
<b>MRV005C</b> MRV005Z	0.60	0.37	6000	12,500	0.45	0.61	0.60	0.81	42	1.2	1¾	0.8
MRV009A <b>MRV009B</b> MRV009C MRV009F	0.88	0.66	3000	8,070	1.7	2.3	2.3	3.1	48	1.4	7½	3.4
<b>MRV015A</b> MRV015B MRV015B5D71 <b>MRV015F</b>	1.5	1.1	3000	7900	2.6	3.5	4.1	5.6	67	1.9	8¾	2.4
<b>MRV040A</b> MRV040B5D71 MRV040B5D80 <b>MRV040F</b>	3.6	2.7	3000	7900	5.3	7.2	8.7	11.8	120	3.4	16¼	7.4
<b>MRV050A</b> MRV050B MRV050B5D90 <b>MRV050F</b>	4.8	3.6	2500	7000	10.0	13.6	14.0	19.0	152	4.3	22½	10.2

ALL models must be operated with sufficient load to prevent speed from exceeding maximum allowable speed shown on performance curve. Performance figures are at 90 psig (620 kPa) air pressure. Popular models shown in bold print.

### Model Designation Breakout

MRV	003	A	L
MRV Series Air Motors	Nominal Series Power:	Shaft/Interface:	Rotation:
	003 => 1/3 Horsepower 005 => 1/2 Horsepower 009 => 3/4 Horsepower 015 => 1-1/2 Horsepower 040 => 4 Horsepower 050 => 5 Horsepower	A => Round Shaft with Square Key (no key on MRV003) B => Round Shaft with Woodruff Key (#3) B5Dxx => with respective B5Dxx Flange Mount C => Round Shaft with Flat on Shaft F => with Foot Mount Bracket Z (MRV003 only) => Flange Mount	L => Left Hand Bias (CCW) R => Right Hand Bias (CW) None => Reversible

### Equipment Options

Series	Furnished with Cataloged Models	Optional at Extra Price
MRV003	3 Hole Face Mounting MRV003A-AF350 Muffler	MRV003A-AG587 Mounting Foot
MRV005	3 Hole Face Mounting MRV003A-AF350 Muffler	MRV003A-AG587 Mounting Foot
MRV009	3 Hole Face Mounting MRV015A-AC980 Muffler	MRV015B-AH636 Mounting Foot MRV009B-AH635 Mounting Flange
MRV015	3 Hole Face Mounting MRV015A-AC980 Muffler	MRV015A-AH634 Mounting Foot MRV015A-AH633 NEMA 56C Mounting Flange
MRV040	3 Hole Face Mounting MRV040A-AC990 Muffler	MRV015A-AH634 Mounting Foot MRV015A-AH633 NEMA 56C Mounting Flange
MRV050	3 Hole Face Mounting MRV040A-AC990	MRV050A-AH640 Mounting Foot MRV050A-AH641 NEMA 182C, 184C, 143TC and 145TC Mounting Flange

## Interchange chart

GAST Model Style	Rotation Bias	FENNER Model Style	SELECT Series Model Style (+Bracket)	HP	rpm	Mounting Style	MRV Series Model Style (+Bracket)
1AM-NCC-12	Left hand (CCW)		SM1AMAL	0.33	15,2	Hub Mount	MRV003AL
1AM-NCW-14	Right Hand (CW)		SM1AMA	0.33	15,2	Hub Mount	MRV003A
1AM-NRV-39A	Reversible		SM1AMA	0.33	15,2	Hub Mount	MRV003A
1AM-NRV-63A	Reversible		SM1AMA	0.33	15,2	Hub Mount	MRV003A
1UP-NCC-1A	Left hand (CCW)		SM1UPCL	0.60	12,5	Hub Mount	MRV005CL
1UP-NCW-2A	Right Hand (CW)		SM1UPCR	0.60	12,5	Hub Mount	MRV005CR
1UP-NRV-3A	Reversible	V1X	SM1UPC	0.60	12,5	Hub Mount	MRV005C
1UP-NRV-10	Reversible		SM1UPC	0.60	12,5	Hub Mount	MRV005C
AG585 bracket	Foot Mount Bracket		SM1AM-AG587 bracket				MRV003A-AG587 bracket
2AM-NCC-16	Left hand (CCW)	2VMX/CCL	SM2AMC	0.88	8,07	Hub or Face Mount	MRV009C <sup>1)</sup>
2AM-NCC-16F	Left hand (CCW)		SM2AMC	0.88	8,07	Hub or Face Mount	MRV009C <sup>1)</sup>
2AM-NCW-7A	Right Hand (CW)	2VMX/CW	SM2AMC	0.88	8,07	Hub or Face Mount	MRV009C <sup>1)</sup>
2AM-NCW-7B	Right Hand (CW)		SM2AMC	0.88	8,07	Hub or Face Mount	MRV009C <sup>1)</sup>
2AM-NRV-89	Reversible	VA2X	SM2AMC	0.88	8,07	Hub or Face Mount	MRV009C <sup>1)</sup>
2AM-FCC-1	Left hand (CCW)	2VMJ/CW	SM2AMC (+SM2AM-AH636)	0.88	8,07	Foot Mount	MRV009C(+MRV015B-AH636) <sup>1)</sup>
2AM-FCW-13	Right Hand (CW)	2VMJ/CW	SM2AMC (+SM2AM-AH636)	0.88	8,07	Foot Mount	MRV009C(+MRV015B-AH636) <sup>1)</sup>
2AM-FRV-501	Reversible	VA2J	SM2AMC (+SM2AM-AH636)	0.88	8,07	Foot Mount	MRV009C(+MRV015B-AH636) <sup>1)</sup>
2AM-NCC-43A	Left hand (CCW)	2VMC/CW	SM2AMAN	0.88	8,07	NEMA56C flange mount	MRV009C(+MRV009B-AH633) <sup>1) 2)</sup>
	Right Hand (CW)	2VMC/CW	SM2AMAN	0.88	8,07	NEMA56C flange mount	MRV009C(+MRV009B-AH633) <sup>1) 2)</sup>
2AM-NRV-90	Reversible	VA2C	SM2AMAN	0.88	8,07	NEMA56C flange mount	MRV009C(+MRV009B-AH633) <sup>1) 2)</sup>
	Left hand (CCW)	4VMX/CW	SM4AMB	1.5	7,9	Hub or Face Mount	MRV015B <sup>3)</sup>
	Right Hand (CW)	4VMX/CW	SM4AMB	1.5	7,9	Hub or Face Mount	MRV015B <sup>3)</sup>
4AM-NRV-22B	Reversible	VA4K	SM4AMB	1.5	7,9	Hub or Face Mount	MRV015B <sup>3)</sup>
4AM-NRV-22F	Reversible		SM4AMB	1.5	7,9	Hub or Face Mount	MRV015B <sup>3)</sup>
4AM-NRV-54A	Reversible		SM4AMB	1.5	7,9	Hub or Face Mount	MRV015B <sup>3)</sup>
	Left hand (CCW)	4VMJ/CW	SM4AMB (+SM4AM-AH634)	1.5	7,9	Foot Mount	MRV015A(+MRV015A-AH634) <sup>3)</sup>
	Right Hand (CW)	4VMJ/CW	SM4AMB (+SM4AM-AH634)	1.5	7,9	Foot Mount	MRV015A(+MRV015A-AH634) <sup>3)</sup>
4AM-FRV-13C	Foot Mount	VA4J	SM4AMB (+SM4AM-AH634)	1.5	7,9	Foot Mount	MRV015A(+MRV015A-AH634) <sup>3)</sup>
4AM-FRV-13H	Foot Mount		SM4AMB (+SM4AM-AH634)	1.5	7,9	Foot Mount	MRV015A(+MRV015A-AH634) <sup>3)</sup>
4AM-FRV-63A	Foot Mount		SM4AMB (+SM4AM-AH634)	1.5	7,9	Foot Mount	MRV015A(+MRV015A-AH634) <sup>3)</sup>
	Left hand (CCW)	4VMC/CW	SM4AMAN	1.5	7,9	NEMA56C flange mount	MRV015A(+MRV015A-AH633)
	Right Hand (CW)	4VMC/CW	SM4AMAN	1.5	7,9	NEMA56C flange mount	MRV015A(+MRV015A-AH633)
4AM-NRV-50C	Reversible	VA4C	SM4AMAN	1.5	7,9	NEMA56C flange mount	MRV015A(+MRV015A-AH633)
4AM-NRV-70C	Reversible		SM4AMAN	1.5	7,9	NEMA56C flange mount	MRV015A(+MRV015A-AH633)
6AM-NRV-7A	Reversible	VA6X	SM6AMA	3.6	7,9	FACE mount	MRV040A <sup>4)</sup>
6AM-FRV-5A	Reversible	VA6J	SM6AMA (+SM6AM-AH634)	3.6	7,9	Foot mount	MRV040A(+MRV015A-AH634) <sup>4)</sup>
6AM-FRV-23A	Reversible		SM6AMA (+SM6AM-AH634)	3.6	7,9	Foot mount	MRV040A(+MRV015A-AH634) <sup>4)</sup>
6AM-NRV-11A	Reversible	VA6C	SM6AMAN	3.6	7,9	NEMA56C flange mount	MRV040A(+MRV015A-AH633)
6AM-NRV-22A	Reversible		SM6AMAN	3.6	7,9	NEMA56C flange mount	MRV040A(+MRV015A-AH633)
8AM-NRV-5B	Reversible	VA8X	SM8AMA	4.8	7	FACE mount	MRV050A <sup>5)</sup>
8AM-NRV-42A	Reversible		SM8AMA	4.8	7	FACE mount	MRV050A <sup>5)</sup>
8AM-FRV-2B	Reversible	VA8J	SM8AMA (+SM8AM-AH640)	4.8	7	Foot Mount	MRV050A(+MRV050A-AH640) <sup>5)</sup>
8AM-FRV-30A	Reversible		SM8AMA (+SM8AM-AH640)	4.8	7	Foot Mount	MRV050A(+MRV050A-AH640) <sup>5)</sup>
8AM-NRV-28A	Reversible	VA8C	SM8AMAN	4.8	7	NEMA182C,-4C,143TC,-5TC	MRV050A(+MRV050A-AH641)
8AM-NRV-32A	Reversible		SM8AMAN	4.8	7	NEMA182C,-4C,143TC,-5TC	MRV050A(+MRV050A-AH641)

<sup>1)</sup> - MRV009C: 3x M6 mounting threads at 3" diameter, comparing to SM2AMC: 3x 1/4"-20 at 2.5" diameter

<sup>2)</sup> - MRV009C& MRV009B-AH635 flange with 1/2" keyed shaft, comparing to SM2AMAN 5/8" keyed shaft to match NEMA 56C

<sup>3)</sup> - MRV015: M6 mounting threads & 5/8" shaft with a square key, comparing to SM4AMB 1/4"-20 mounting threads & 1/2" shaft with a woodruff key.

<sup>4)</sup> - MRV040A: M6 mounting threads on a 3" diameter, SM6AMA: 5/16"-18 mounting holes on a 4" diameter.

<sup>5)</sup> - MRV050A: 3x M6 mounting threads on a 1 1/4" diameter, and 7/8" shaft, SM8AMA: 4x 3/8"-16 mounting holes on a 3.88" diameter and 3/4" shaft.

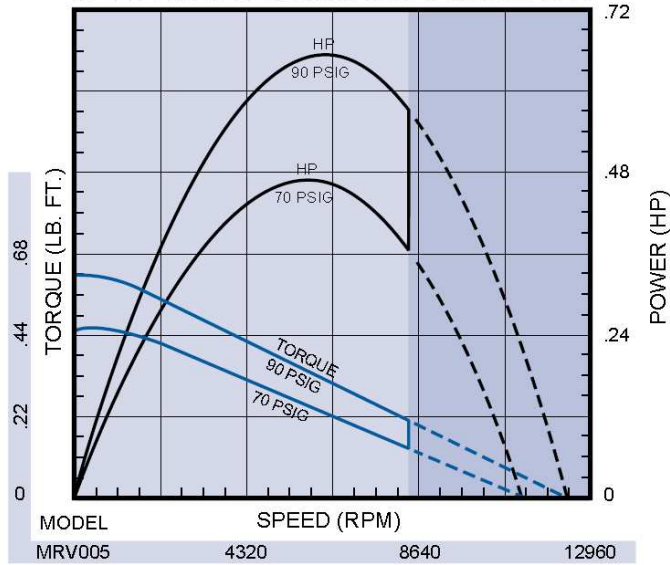
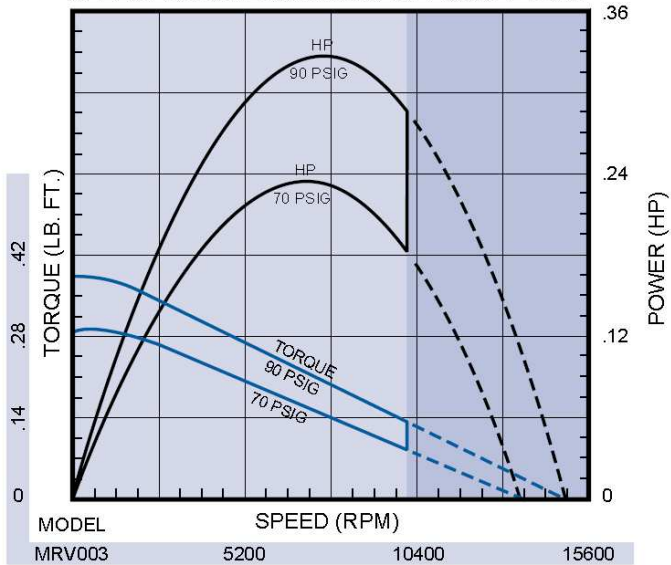
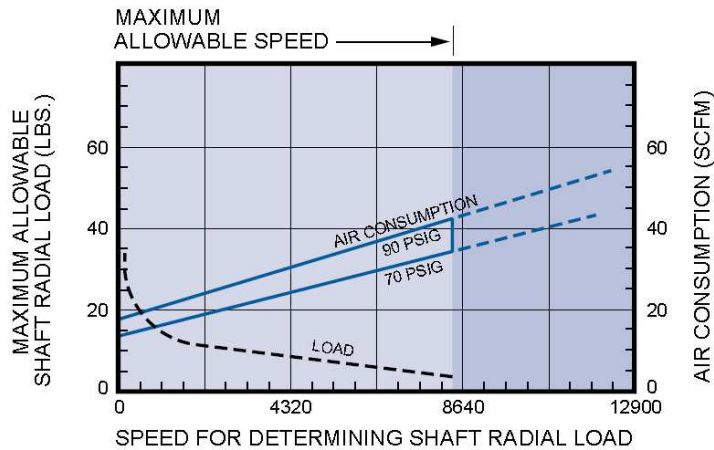
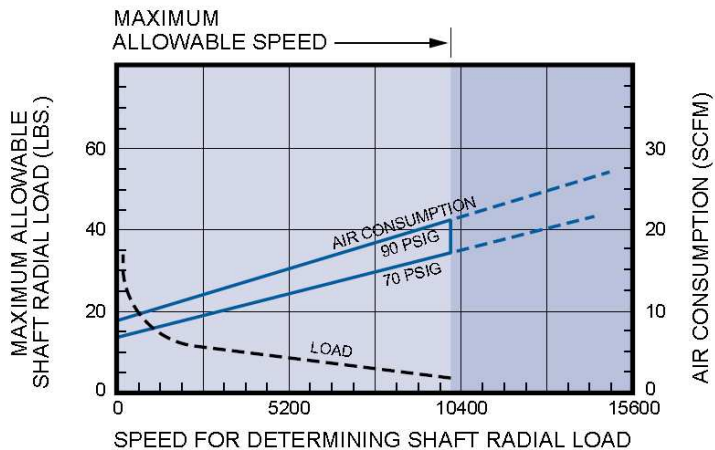

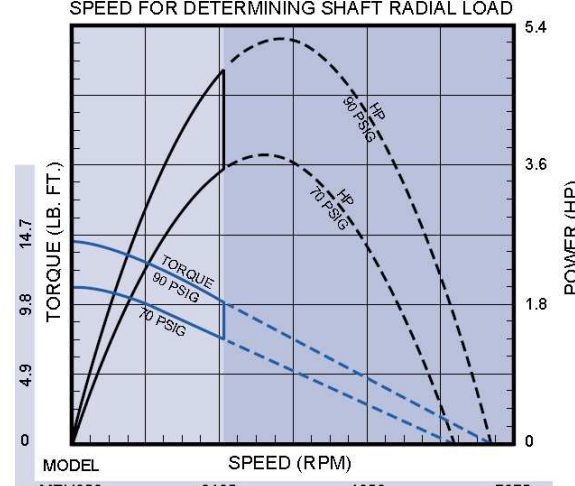
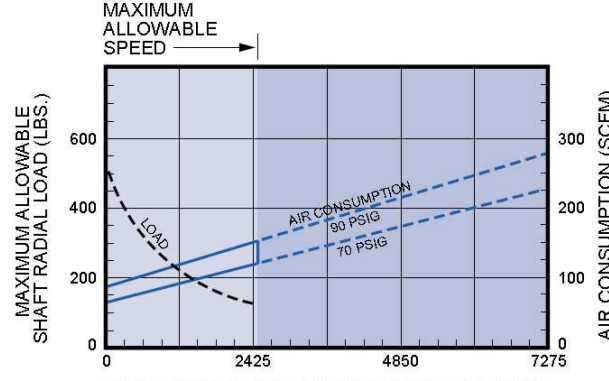
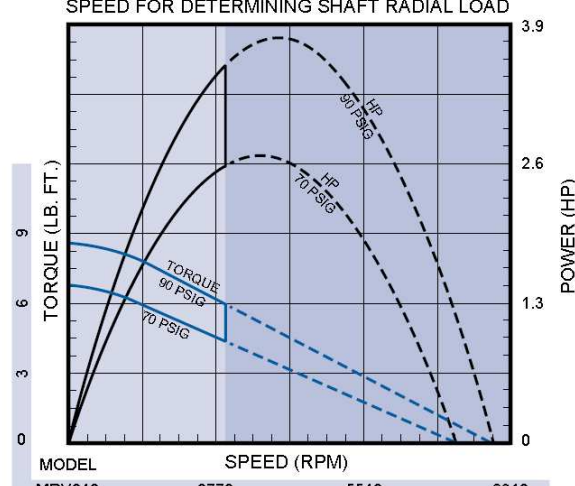
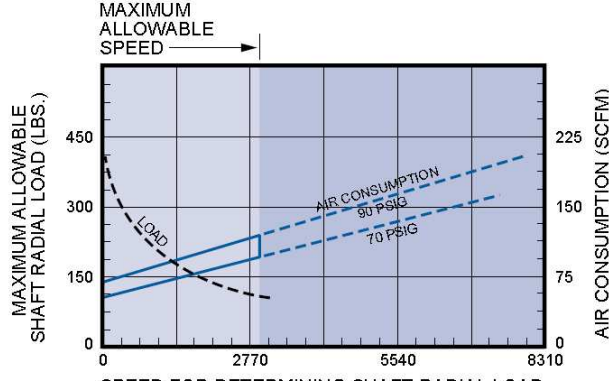
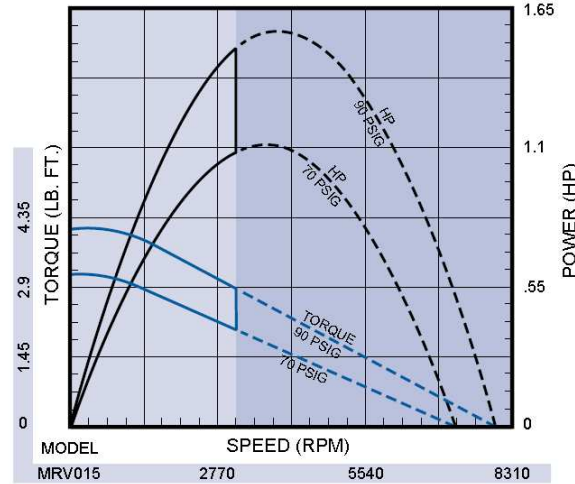
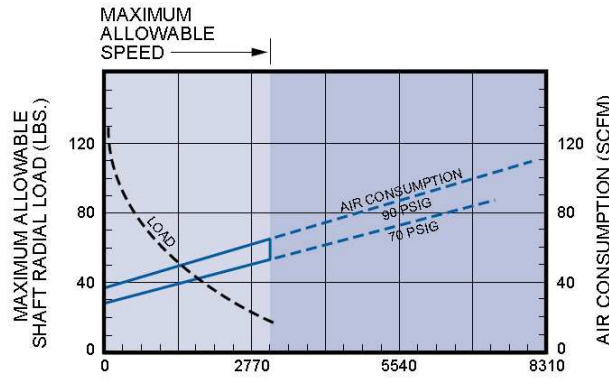
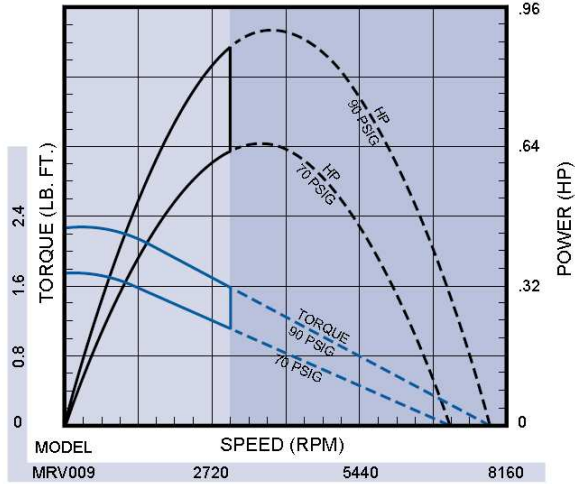
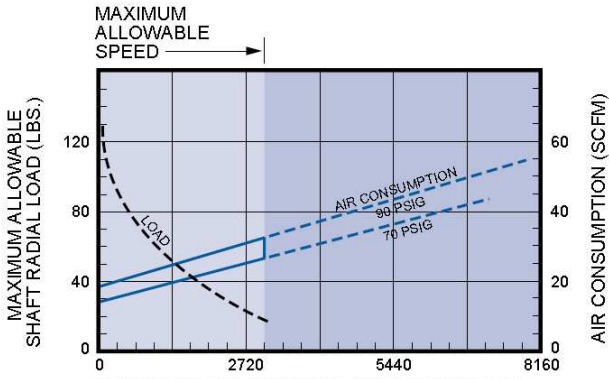



**MRV003A / MRV003A with MRV003A-AG587 Mounting Foot**

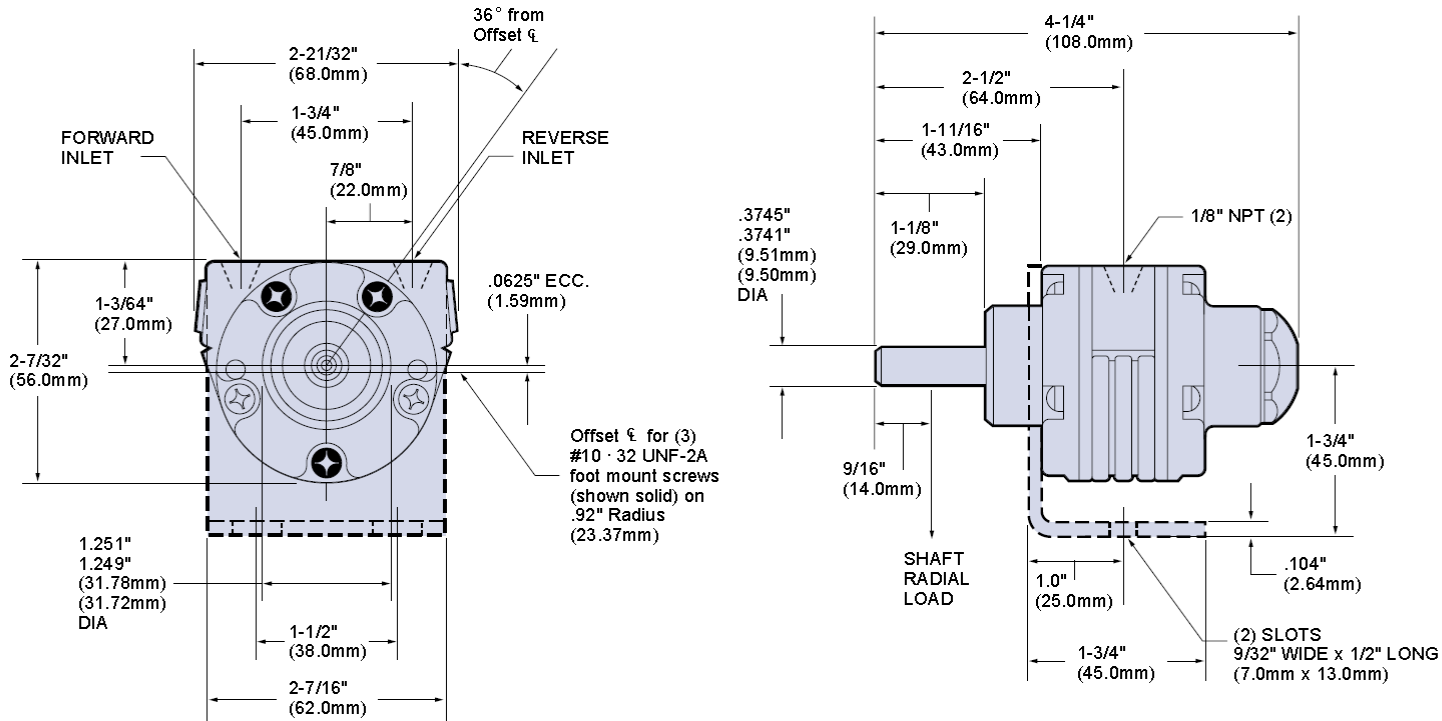

**MRV005C / MRV005C with MRV003A-AG587 Mounting Foot**

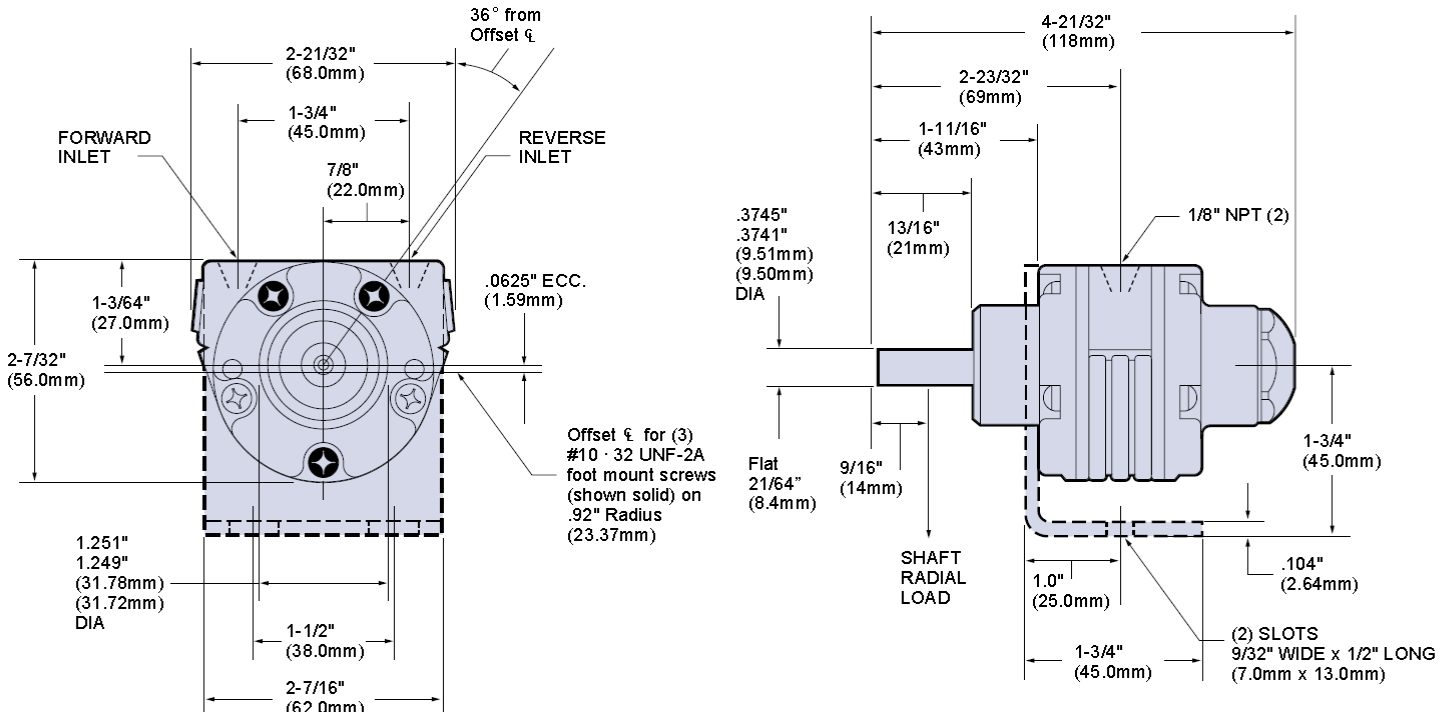

**MRV009B / with MRV015B-AH636 foot (MRV009F) / with MRV009B-AH635 flange**

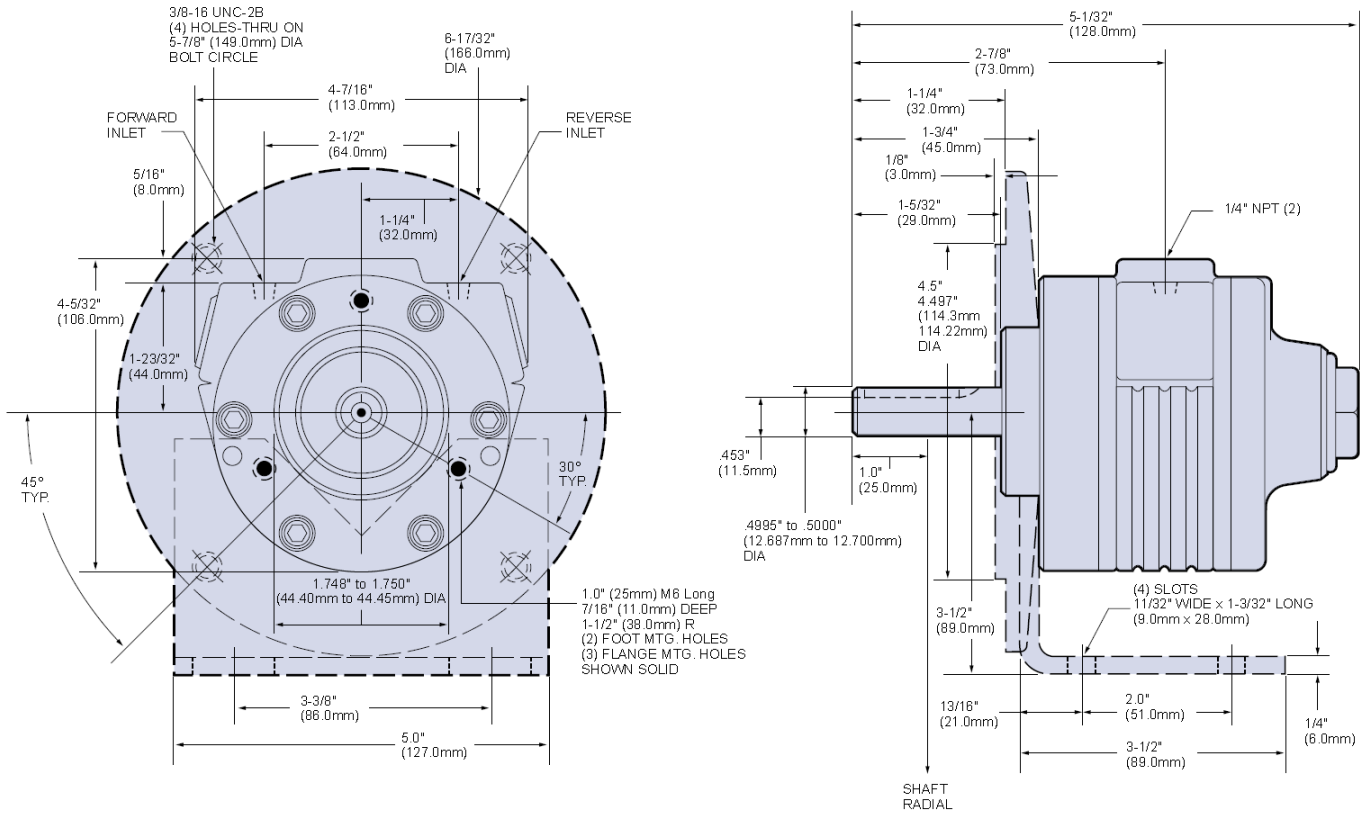

**MRV015A / with MRV015A-AH634 foot (MRV015F) / with MRV015A-AH633 flange**

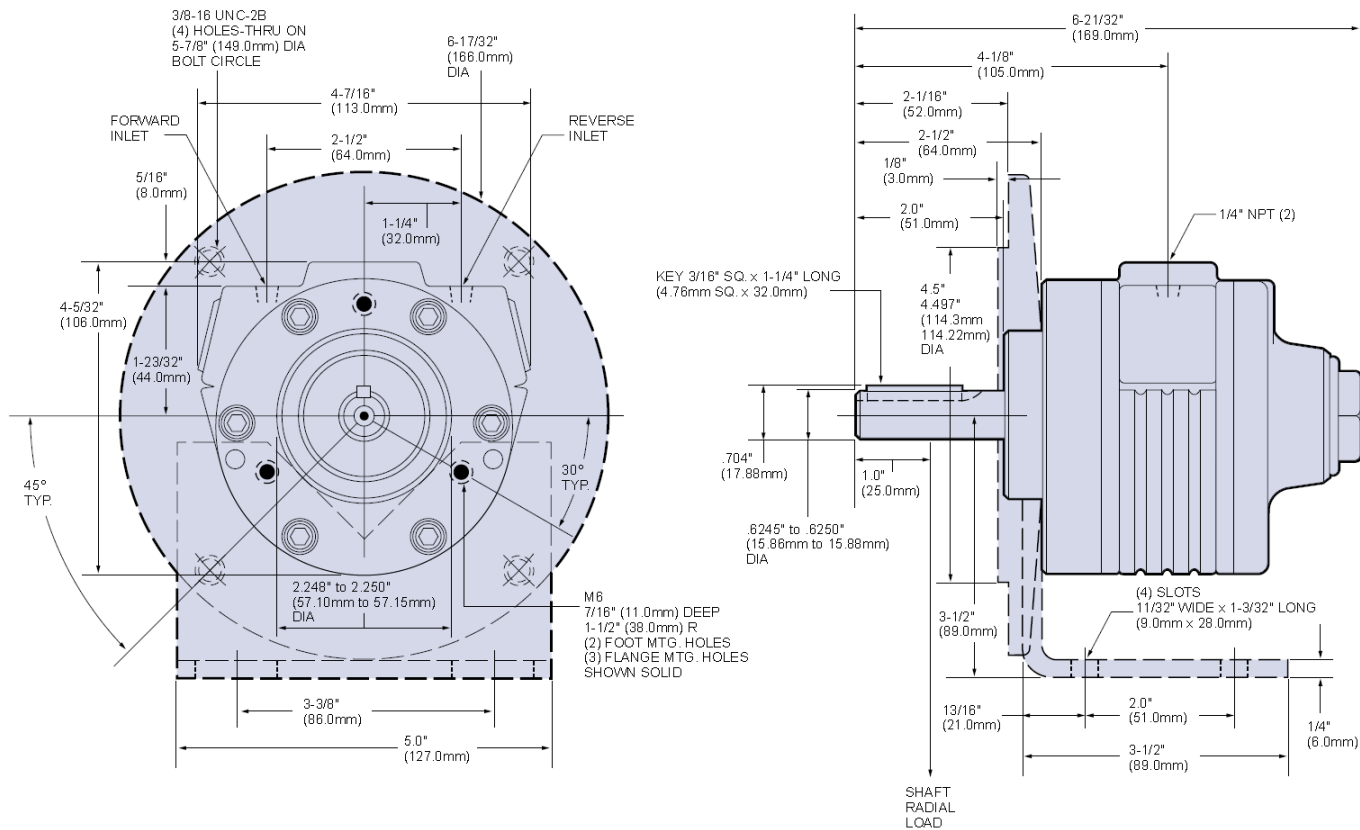

**MRV040A / with MRV015A-AH634 foot (MRV040F) / with MRV015A-AH633 flange**

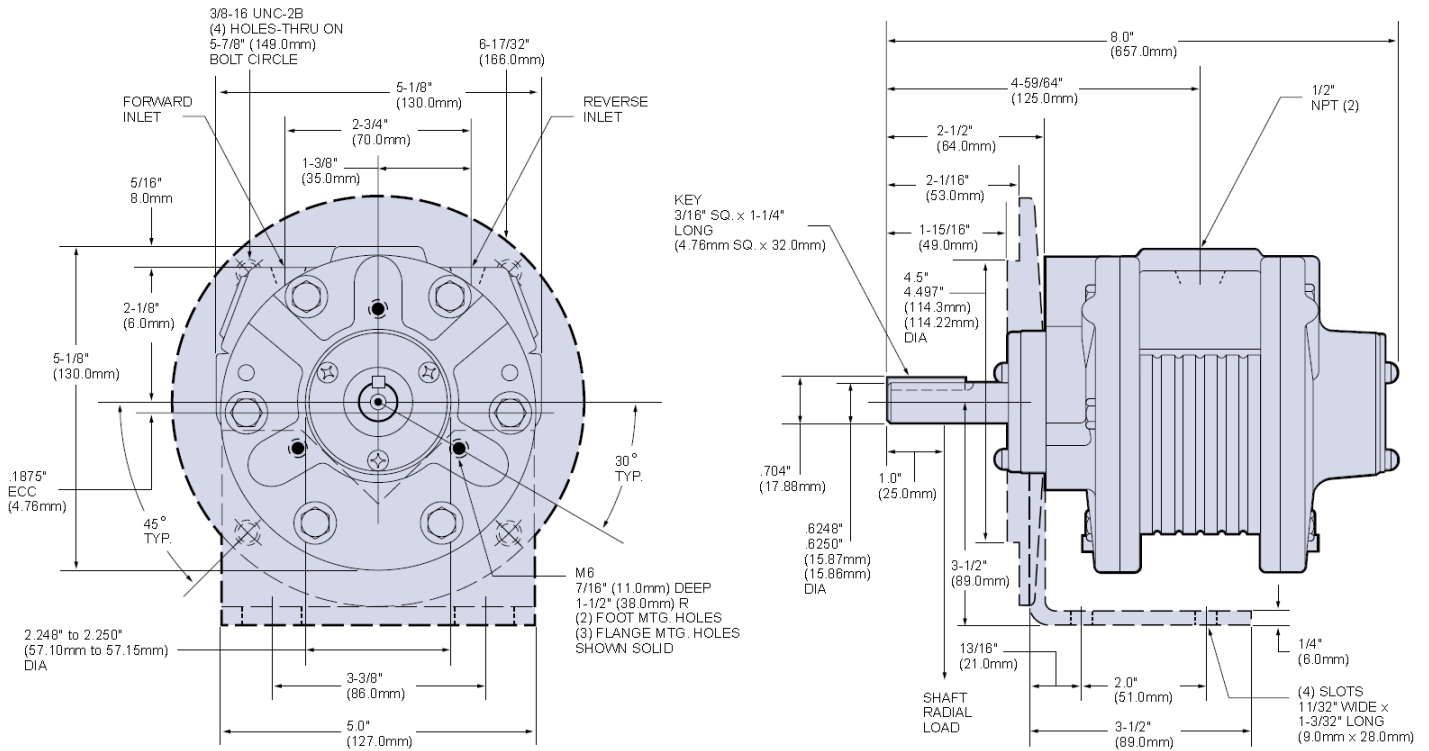

**MRV050A / with MRV050A-AH640 foot (MRV050F) / with MRV050A-AH641 flange**

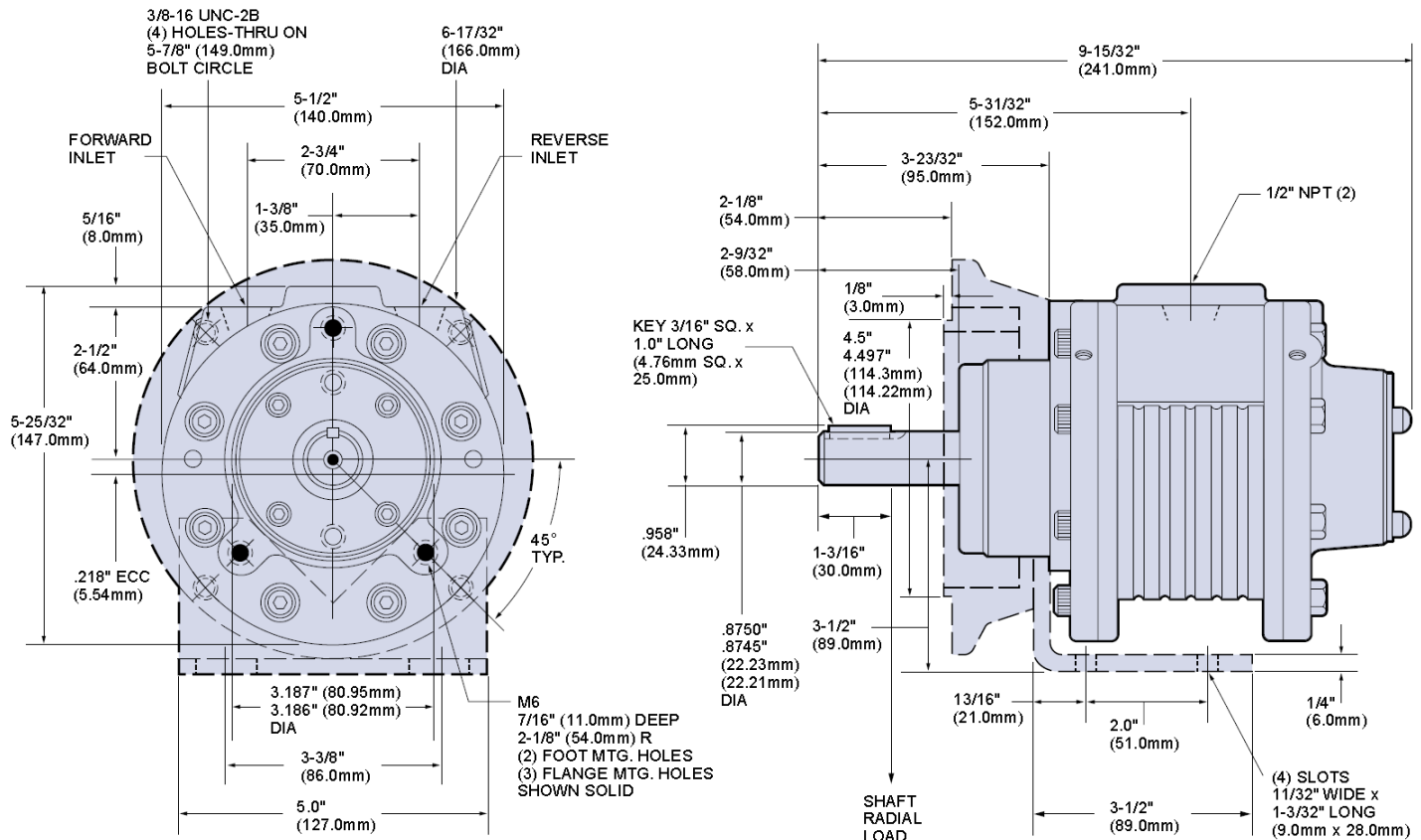

## Rotary-Vane Pneumatic Milling and Sawing Motors



**FIGURE 1**

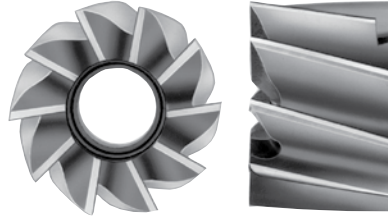

**FIGURE 2**



**FIGURE 3**



**FIGURE 4**

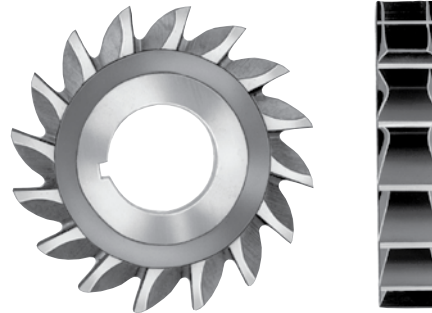

**FIGURE 5**



ARO milling and sawing motors have been used on such diverse applications as milling screw slots in molded fiberglass and straddle milling a 3/4" hex shape on round bar stock. For cost reduction in secondary machining, it is feasible to install a mill motor on the cross-slide of a machine to mill or spotface a slot or diameter on the outside diameter of a workpiece. ARO's mill motor range covers the majority of primary and secondary machining applications. Industrial milling cutters are available in a wide variety of kinds, sizes and shapes for specific applications. Certain basic types are normally used with ARO milling motors.

1. **End Mills.** These are designed for milling slots, keyways and pockets where arbor-type cutters cannot be applied. The cutting edges, as the name implies, are at the end of the mill rather than on the circumference.
2. **Shell End Mills.** Similar in application to standard end mills, except that they are mounted to an arbor and used whenever the diameter of a standard end mill is too small for the application.
3. **Woodruff Key Slot Cutters.** Used for cutting keyslots in arbors or shafts for standard Woodruff keys. Available in arbor-type or shank-type.
4. **Plain Metal-Slitting Saws.** These cutters are designed with teeth around the entire circumference. Sides are concave to provide clearance in cutoff operations and for slotting heads of screws and shafts.
5. **Side Milling Cutters.** Used for milling plain and flat surfaces.

Proper motor selection should be governed by the fact that motor load speed, or the point at which peak horsepower is reached, occurs at approximately one-half the catalogued free speed. Feed rate should be controlled to load the motor to peak horsepower for maximum efficiency. The load-speed column on each catalog page should be used for motor selection. Feed rate and cutting speed will determine the amount of horsepower required for a specific application.

Three factors determine correct milling motor selection:

1. Horsepower-Formula given below.
2. RPM-Refer to chart for correct speed according to type of material.
3. Feed rate on face mills, or per-tooth rate on slotting, side mills or end mills.

**FORMULA FOR MODEL SELECTION**

$$HP = \frac{\text{Width of cut} \times \text{depth of cut} \times \text{feed rate per min.}}{K \text{ Factor}}$$

F, feed rate = f, feed per tooth x t, number of teeth x n, RPM of cutter. Alternately, see reference chart.

$$RPM = \frac{4 \times \text{SFM or surface feet per minute}}{D, \text{ diameter of cutter in inches}}$$

**K Factors for Common Materials**

Material	K	Material	K	Material	K	Material	K
Magnesium	4.0	Cast Iron Ferritic Pearlitic Chilled Steel To 150 To 300	1.5 1.0 .6 1.0 .8	To 400	.5	220,000-260,000 p.s.i. 260,000-300,000 p.s.i.	.4
Aluminum	4.0			To 500	.4		
Copper	2.0			Stainless Steel	1.0 .6 .5	High Temperature Alloys Nickel Base Cobalt Base Austenitic	.4 .4 .4
Brass	2.5			Free Machining			
Bronze	2.0			Other			
Malleable Iron	1.0	High-Tensile Alloys 180,000-220,000 p.s.i.	.5				

**REFERENCE CHART**

Work Material	Hardness BHN	Speed R.P.M.	Feed Per Minute Face Mills	Feed Per Tooth		Work Material	Hardness BHN	Speed R.P.M.	Feed Per Minute Face Mills	Feed Per Tooth	
				Slotting & Side Mills	End Mills					Slotting & Side Mills	End Mills
Free Machining Steels, Plain Carbon Steels, Alloy Steels, Series 400 & 500 Stainless	150	500-900	.010-.014	.008-.010	.002-.004	Magnesium Alloys	-	900-1600	.012-.018	.010-.014	.003-.005
	200	450-800	.010-.014	.008-.010	.002-.004	Aluminum Alloys Low Silicon High Silicon	1200-1800 900-1200	.012-.018 .008-.012	.010-.014 .008-.010	.003-.006 .003-.005	
	250	400-700	.008-.010	.006-.008	.001-.003						
	300	350-600	.008-.010	.006-.008	.001-.003						
350	300-450	.006-.008	.004-.006	.001-.003							
Series 200-300 Stainless Sheets	150-250	250-450	.006-.010	.006-.008	.001-.003	Titanium Pure	100-275	250-350	.004-.006	.004-.006	.002-.003
Hot Work Tool Steels	150-250	350-450	.010-.012	.006-.010	.001-.003	Copper Alloys	20-70 RB 60-100 RB	900-1300 800-1000	.012-.016 .008-.012	.008-.012 .007-.010	.003-.004 .002-.004
	200-250	250-350	.008-.010	.005-.008	.001-.002						
Cold Work Tool Steels	200-250	250-350	.007-.010	.005-.008	.001-.003	Brass & Bronze	To 200	600-900	.010-.012	.008-.010	.003-.004
High-Manganese Steel	170-220	100-200	.007-.010	.005-.008	.002-.003	Zinc Alloys	Cast	800-1100	.006-.009	.005-.008	.002-.003
Gray Cast Iron	110-220	300-400	.012-.016	.008-.012	.002-.004	Man-ganese	140-220	150-200	.005-.008	.004-.006	.002-.004
	220-320	125-250	.008-.012	.006-.010	.002-.003						
Nodular Iron	140-250	325-450	.012-.016	.008-.012	.002-.004	Thermo-plastics	-	500-1100	.006-.010	.005-.008	.003-.005
	250-400	225-300	.008-.012	.006-.010	.002-.003						
Malleable Iron	110-220 200-280	250-350 200-300	.012-.016 .008-.012	.008-.012 .006-.010	.002-.004 .002-.003	Thermo-setting Plastics	-	500-1100	.006-.010	.005-.008	.003-.005

## 000-Series Forward-Rotation Milling Motors (1/4" Capacity)

### Specifications

MODEL	SPINDLE	R.P.M.		TORQUE				AIR		SOUND LEVEL	WEIGHT		GEAR
		FREE SPEED	LOAD @MAX. H.P.	STALL	OUTPUT @MAX. H.P.	CONSUMPTION @FREE SPEED	CONSUMPTION L/s	@FREE SPEED	lbs.	kg.	REDUCTION		
<b>NON-REVERSIBLE - .25 H.P.</b>													
7533-2-B	1/4"	550	325	8.2	10.6	4.0	5.1	18.1	8.5	75	2.07	.93	Double
7534-2-B	Maximum	900	550	5.0	6.4	2.4	3.2	18.1	8.5	75	2.07	.93	Double
7535-2-C	Collet	2,700	1,600	1.75	2.2	.82	1.1	18.1	8.5	75	1.77	.80	Single
7536-2-B	Capacity	4,500	2,700	1.05	1.3	.49	.6	18.1	8.5	75	1.77	.80	Single
7537-2-C		20,000	12,000	.22	.30	.11	.1	18.1	8.5	75	1.77	.80	Single

Collet Insert No.	Size	Minimum Capacity		Maximum Capacity	
		Inches	mm	Inches	mm
31812-1	3/64"	1/64"	.40	3/64"	1.19
31812-2	5/64"	3/64"	1.19	5/64"	1.98
31812-3	3/32"	1/16"	1.59	3/32"	2.38
31812-4	1/8"	3/32"	2.38	1/8"	3.18
31812-5	5/32"	1/8"	3.18	5/32"	3.97
31812-6	3/16"	5/32"	3.97	3/16"	4.76
31812-7	7/32"	3/16"	4.76	7/32"	5.56
31812-8	1/4"	7/32"	5.56	1/4"	6.35

Approx. Tooling Penetration - 1 1/8" (28.6mm)

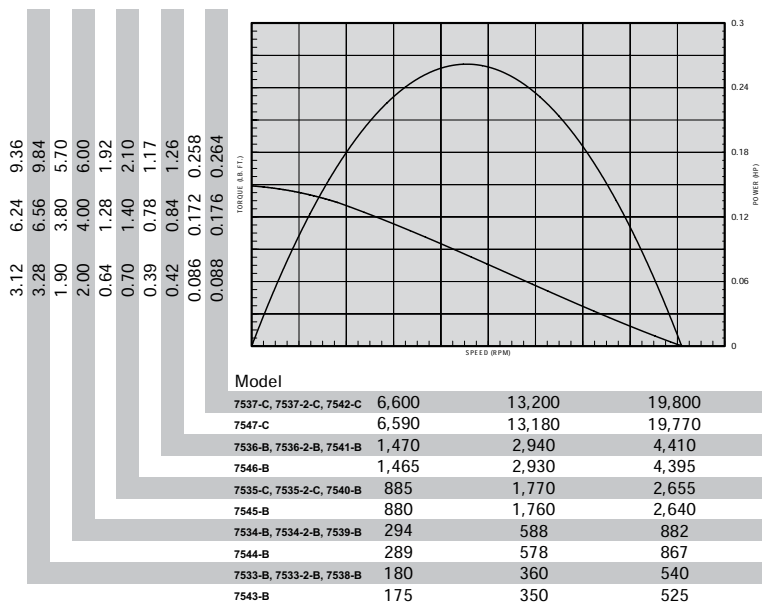

### Standard Equipment

Steel motor housing, flush-type grease fittings at rotation points for gear and bearing lubrication, exhaust manifold rotatable within 360°, muffler, integral collet spindle with 31812-8 1/4" capacity collet for end mills and Woodruff key slot cutters, duplex bearing on drive spindle for maximum radial support.



### No Cost Option

Another size collet insert may be substituted for the standard 1/4" capacity insert. Specify collet insert 31812-( ) in the desired size from the chart above.

### Equipment Options

- 41563 Flange Bracket
- 45088 Foot Bracket





## 000-Series Milling Motors and Mounting Accessory Dimensions

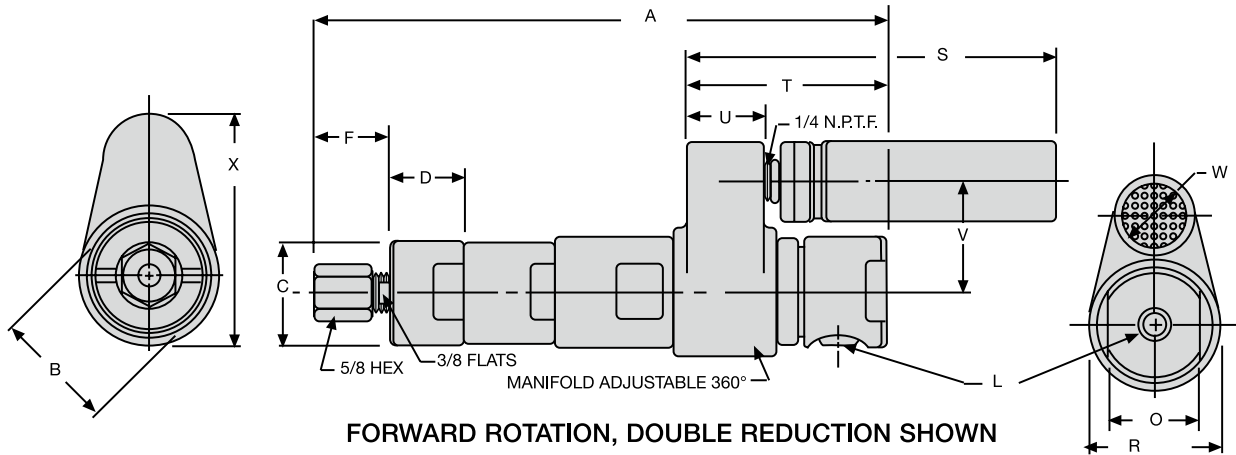

Models	Gear Reduction	Dimension A
7535-2-C, 7536-2-B 7537-2-C	Single	5-15/16 151 mm
7533-2-B, 7534-2-B	Double	7 178 mm

Scale	B	C	D	F	L	O	R
Inches	1-3/8	1.311 1.312	.870 .890	15/16 (Approx.)	1/8 NPTF	1-1/8	1-5/8
mm	35	33.30 33.32	22.10 22.61	24 (Approx.)	Air Inlet	28	41

Scale	S	T	U	V	W	X
Inches	4-9/16	2-15/32	31/32	1-3/8	1	2-11/16
mm	116	63	25	35	25	68

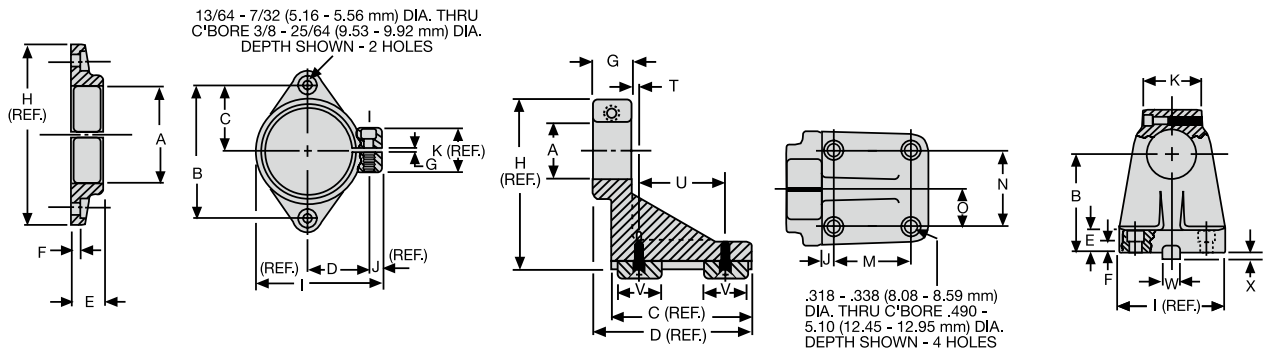

**41563 FLANGE MOUNTING BRACKET**

**45088 FOOT MOUNTING BRACKET**

Scale	A	B	C	D	E	F
Inches	1.312 1.314	2.745 2.755	1.370 1.380	1.240 1.260	.490 .510	.146 .166
mm	33.32 33.38	69.72 69.98	34.80 35.05	31.50 32.00	12.45 12.95	3.71 4.22

Scale	A	B	C	D	E	F	G	H	I	J
Inches	1.312 1.313	2.749 2.751	3-1/4	3-11/16	.609 .640	.296 .328	.875 .973	4	3	.343 .375
mm	33.32 33.35	69.82 69.88	82.55	93.66	15.47 16.26	7.52 8.33	22.23 23.80	101.60	76.20	8.71 9.53

Scale	G	H	I	J	K
Inches	1/64 3/64	3-3/8	2-9/16	1/4	1
mm	0.40 1.19	85.73	65.09	6.35	25.40

Scale	K	M	N	O	T	U	V	W	X
Inches	1.542 1.582	1.995 2.005	1.995 2.005	.995 1.005	.140 .156	1.984 2.015	.985 1.015	.499 .500	.173 .198
mm	39.17 40.18	50.67 50.93	50.67 50.93	25.27 25.53	3.56 3.96	50.39 51.18	25.02 25.78	12.67 12.70	4.39 5.03

## O-Series Forward-Rotation Milling Motors

### Specifications

MODEL	SPINDLE	R.P.M.		TORQUE		OUTPUT		AIR CONSUMPTION		SOUND LEVEL	WEIGHT		GEAR
		FREE SPEED	LOAD SPEED @MAX. H.P.	STALL lb. ft.	Nm	@MAX. H.P. lb. ft.	Nm	@FREE SPEED SCFM	L/s	@FREE SPEED dB(A)	lbs.	kg.	REDUCTION
<b>NON-REVERSIBLE - .60 H.P.</b>													
8232-1	1/4" Maximum Collet Capacity	19,000	9,800	.70	.9	.32	.4	41.0	19.4	80	2.87	1.29	Single
8232-2		5,700	2,900	2.15	2.9	1.10	1.5	41.0	19.4	80	2.87	1.29	Single
8232-3		3,500	1,750	3.50	4.7	1.80	2.4	41.0	19.4	80	2.87	1.29	Single
8232-4		2,800	1,400	4.50	6.1	2.20	3.0	41.0	19.4	80	2.87	1.29	Single
8232-5		1,650	840	7.50	10.2	3.80	5.1	41.0	19.4	80	3.62	1.63	Double
8232-6		1,000	500	12.00	16.3	6.20	8.4	41.0	19.4	80	3.62	1.63	Double
8232-7		800	390	14.80	20.0	8.00	10.8	41.0	19.4	80	3.62	1.63	Double

Collet Insert No.	Size	Minimum Capacity		Maximum Capacity	
		Inches	mm	Inches	mm
31812-1	3/64"	1/64"	.40	3/64"	1.19
31812-2	5/64"	3/64"	1.19	5/64"	1.98
31812-3	3/32"	1/16"	1.59	3/32"	2.38
31812-4	1/8"	3/32"	2.38	1/8"	3.18
31812-5	5/32"	1/8"	3.18	5/32"	3.97
31812-6	3/16"	5/32"	3.97	3/16"	4.76
31812-7	7/32"	3/16"	4.76	7/32"	5.56
31812-8	1/4"	7/32"	5.56	1/4"	6.35

Approx. Tooling Penetration - 1 1/4" (31.8mm)

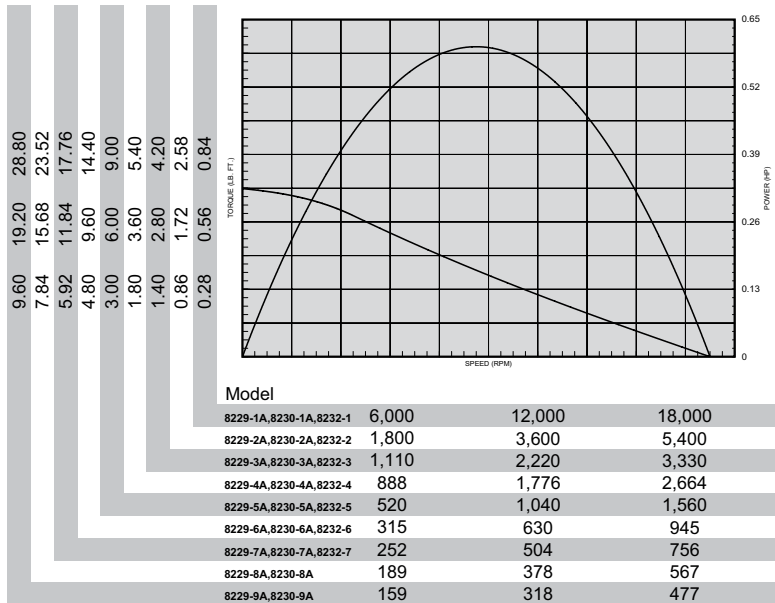

### Standard Equipment

Steel motor housing, flush-type grease fittings at rotation points for gear and bearing lubrication, exhaust manifold rotatable within 360°, muffler, integral collet spindle with 31812-8 1/4" capacity collet for end mills and Woodruff key slot cutters, duplex bearing on drive spindle for maximum radial support.



### No Cost Option

Another size collet insert may be substituted for the standard 1/4" capacity insert. Specify collet insert 31812-( ) in the desired size from the chart above.

### Equipment Options

45057 Foot Bracket

41561 Flange Bracket

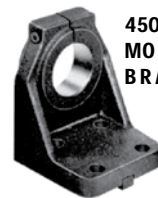

**45057 FOOT MOUNTING BRACKET**



**41561 FLANGE MOUNTING BRACKET**

## O-Series Milling Motors and Mounting Accessory Dimensions

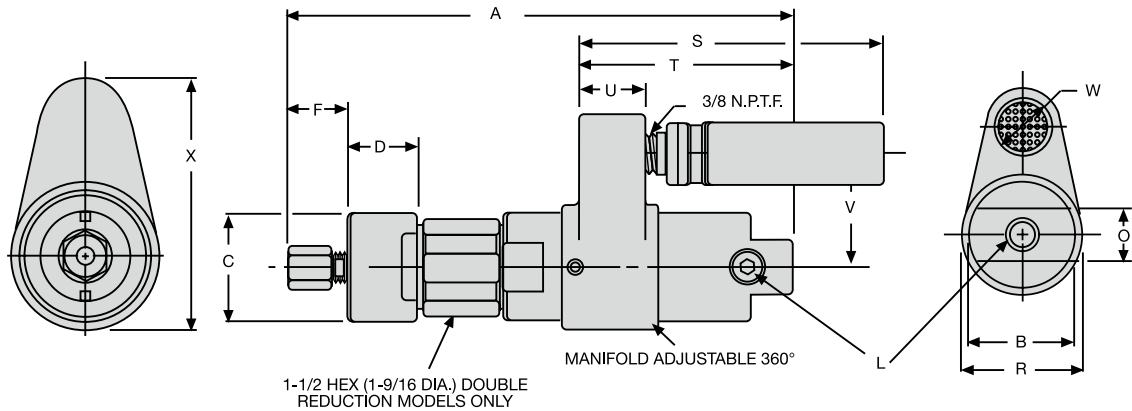

**FORWARD ROTATION, DOUBLE REDUCTION SHOWN**

Models	Gear Reduction	Dimension A
8232-( )	Single	6-7/8 175 mm
	Double	8-3/16 208 mm

Scale	B	C	D	F	L	O	R
Inches	1-3/4	1.740 1.739	1-5/32	15/16 (Approx.)	1/4 NPTF	7/8	2
mm	44	44.20 44.17	29	24 (Approx.)	Air Inlet	22	51

Scale	S	T	U	V	W	X
Inches	4-7/8	3-13/32	1-1/16	1-13/16	1	3-7/16
mm	124	86	27	46	25	87

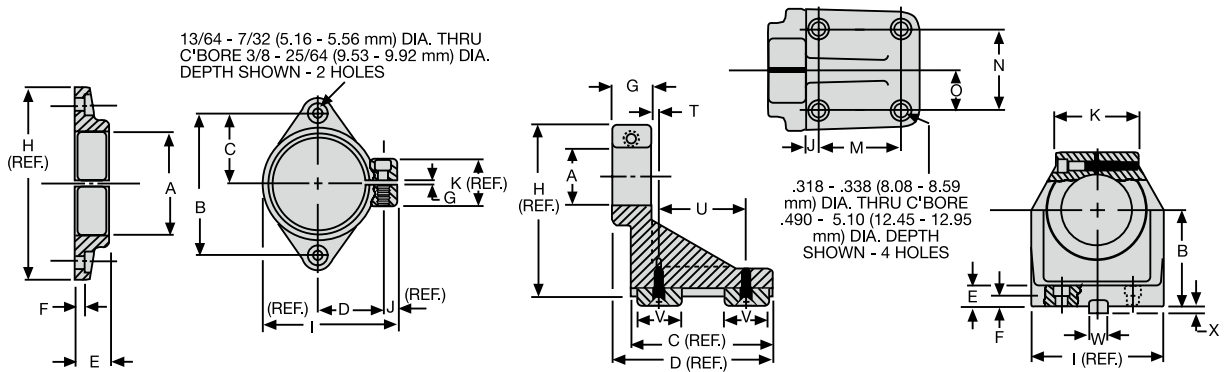

**41561 FLANGE MOUNTING BRACKET**

**45057 FOOT MOUNTING BRACKET**

Scale	A	B	C	D	E	F
Inches	1.741 1.740	2.745 2.755	1.370 1.380	1.240 1.260	.490 .510	.146 .166
mm	44.22 44.20	69.72 69.98	34.80 35.05	31.50 32.00	12.45 12.95	3.71 4.22

Scale	A	B	C	D	E	F	G	H	I	J
Inches	1.741 1.740	2.749 2.751	3-9/16	3-3/4	.609 .640	.296 .328	1"	4-3/8	3-3/4	.296 .328
mm	44.22 44.20	69.82 69.88	90.49	95.25	15.47 16.26	7.52 8.33	25.40	111.13	95.25	7.52 8.33

Scale	G	H	I	J	K
Inches	1/64 3/64	3-3/8	2-9/16	1/4	1
mm	0.40 1.19	85.73	65.09	6.35	25.40

Scale	K	M	N	O	T	U	V	W	X
Inches	2.343 2.406	1.995 2.005	1.995 2.005	.995 1.005	.109 .140	1.984 2.015	.985 1.015	.499 .500	.173 .198
mm	59.41 61.11	50.67 50.93	50.67 50.93	25.27 25.53	2.77 3.56	50.39 51.18	25.02 25.78	12.67 12.70	4.39 5.03

## 2200-Series Forward-Rotation Milling Motors

### Specifications

MODEL	SPINDLE	R.P.M.		TORQUE				AIR CONSUMPTION		SOUND LEVEL	WEIGHT		GEAR
		FREE SPEED	LOAD SPEED @MAX H P	STALL	OUTPUT @MAX. H.P.	STALL	OUTPUT @MAX. H.P.	@FREE SPEED	@FREE SPEED	dB(A)	lbs	kg	REDUCTION
<b>NON-REVERSIBLE - .85 H.P.</b>													
7800-2B	3/8" Maximum Collet Capacity	18,000	9,000	1.00	1.4	.50	.68	41.7	19.7	78	4.89	2.20	Single
7801-2B		4,600	2,400	4.00	5.5	1.86	2.5	41.7	19.7	78	4.89	2.20	Single
7802-2B		2,500	1,300	7.50	10.3	3.43	4.7	41.7	19.7	78	4.89	2.20	Single
7803-2B		1,200	600	16.00	21.9	7.44	10.2	41.7	19.7	78	6.39	2.86	Double
7804-2B		650	320	30.00	41.2	13.95	19.1	41.7	19.7	78	6.39	2.86	Double

### COLLET SLEEVES

Collet Insert No.	Size	Minimum Capacity		Maximum Capacity	
		Inches	mm	Inches	mm
32968-1	1/8"	3/32"	2.38	1/8"	3.18
32968-2	5/32"	1/8"	3.18	5/32"	3.97
32968-3	3/16"	5/32"	3.97	3/16"	4.76
32968-4	7/32"	3/16"	4.76	7/32"	5.56
32968-5	1/4"	7/32"	5.56	1/4"	6.35
32968-6	9/32"	1/4"	6.35	9/32"	7.14
32968-7	5/16"	9/32"	7.14	5/16"	7.94
32968-8	11/32"	5/16"	7.94	11/32"	8.73
32968-9	3/8"	11/32"	8.73	3/8"	9.53

### Approx. Tooling Penetration - 2" (51 mm)

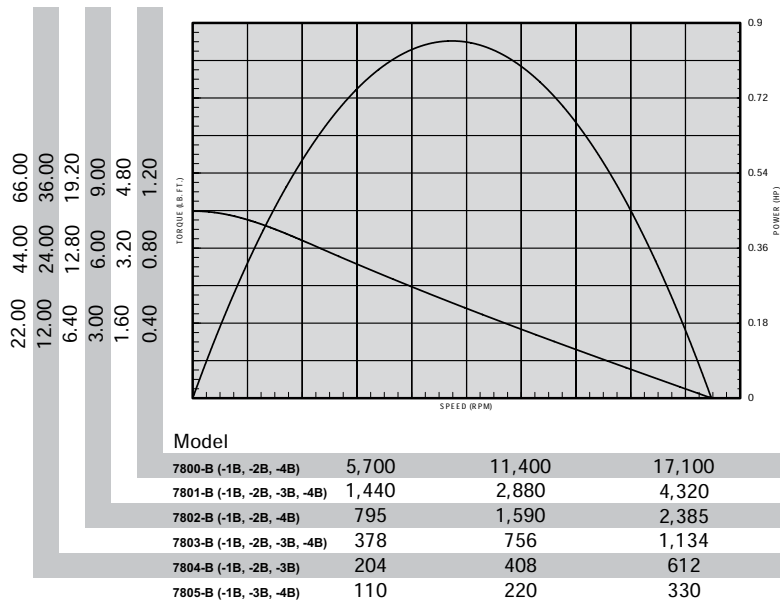

### Standard Equipment

Steel motor housing, flush-type grease fittings at rotation points for gear and bearing lubrication, exhaust manifold rotatable within 360°, muffler, integral collet spindle with 32968-9 3/8" capacity collet for end mills and Woodruff key slot cutters, duplex bearing support on drive spindle for maximum radial support.



### No Cost Option

Another size collet insert may be substituted for the standard 3/8" capacity insert. Specify collet insert 32968-( ) in the desired size from the chart above.

### Equipment Options

- 45058 Foot Bracket
- 41559 Flange Bracket



**45058 FOOT MOUNTING BRACKET**



**41559 FLANGE MOUNTING BRACKET**

## 2200-Series Milling Motors and Mounting Accessory Dimensions

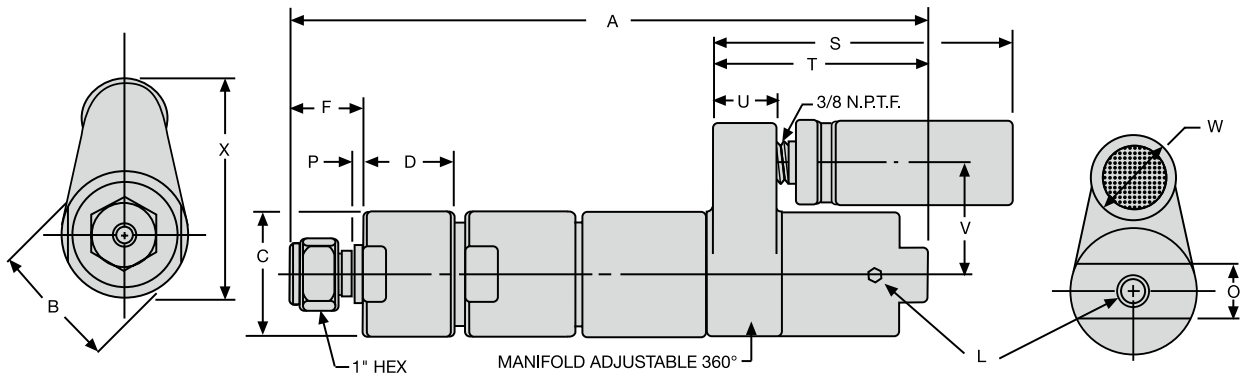

FORWARD ROTATION, DOUBLE REDUCTION SHOWN

Models	Gear Reduction	Dimension A
7800-2B, 7801-2B, 7802-2B	Single	8-11/32 212 mm
7803-2B, 7804-2B, 7805-2B	Double	10-1/16 255 mm

Scale	B	C	D	F	L	O
Inches	2	2.001 2.000	1.422 1.452	1-5/32 (Approx.)	1/4 NPTF	7/8
mm	51	50.80 50.83	36.12 36.88	29 (Approx.)	Air Inlet	22

Scale	P	S	T	U	V	W	X
Inches	.097 .157	4-7/8	3-1/2	1-1/16	1-13/16	1-3/8	3-1/2
mm	2.46 3.99	124	89	27	46	35	89

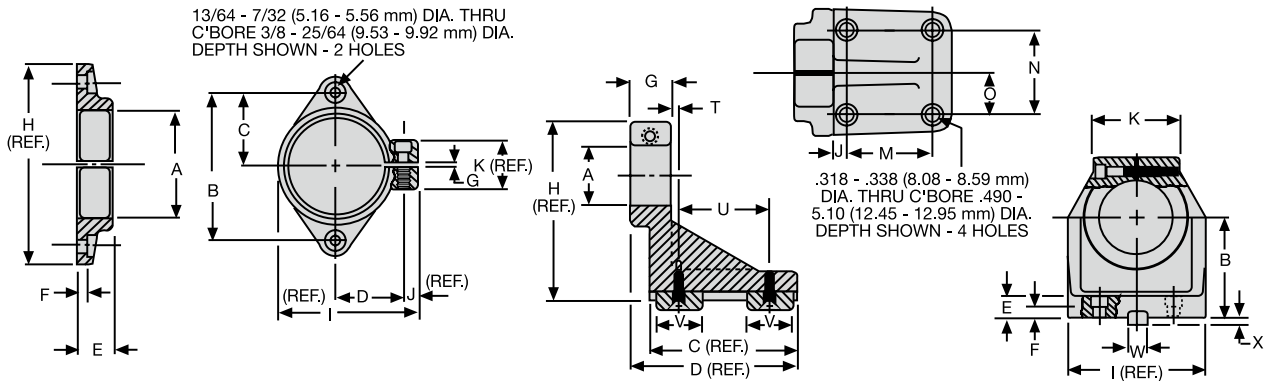

41559 FLANGE MOUNTING BRACKET

45058 FOOT MOUNTING BRACKET

Scale	A	B	C	D	E	F
Inches	2.000 2.002	2.990 3.010	1.490 1.510	1.365 1.385	.661 .681	.177 .197
mm	50.80 50.85	75.95 76.45	37.85 38.35	34.67 35.18	16.79 17.30	4.50 5.00

Scale	A	B	C	D	E	F	G	H	I	J
Inches	2.000 2.001	2.749 2.751	3-9/16	3-3/4	.609 .640	.296 .328	1"	4-3/8	3-3/4	.296 .328
mm	50.80 50.83	69.82 69.88	90.49	95.25	15.47 16.26	7.52 8.33	25.40	111.13	95.25	7.52 8.33

Scale	G	H	I	J	K
Inches	1/64 3/64	3-5/8	2-7/8	5/16	1
mm	0.40 1.19	92.08	73.03	7.94	25.40

Scale	K	M	N	O	T	U	V	W	X
Inches	2.343 2.406	1.995 2.005	1.995 2.005	.995 1.005	.109 .140	1.984 2.015	.985 1.015	.499 .500	.173 .198
mm	59.41 61.11	50.67 50.93	50.67 50.93	25.27 25.53	2.77 3.56	50.39 51.18	25.02 25.78	12.67 12.70	4.39 5.03

## 2200-Series Forward-Rotation Straddle Mount Milling Motors

### Specifications

MODEL	SPINDLE	R.P.M.		TORQUE				AIR		SOUND LEVEL @FREE SPEED dB(A)	WEIGHT		GEAR REDUCTION
		FREE SPEED	LOAD SPEED @MAX. H.P.	STALL	OUTPUT @MAX. H.P.	CONSUMPTION @FREE SPEED	SCFM	L/s	lbs.		kg.		
<b>NON-REVERSIBLE - .85 H.P.</b>													
7801-3B	7/16"-20 UNF-3A	4,600	2,400	4.00	5.5	1.86	2.5	41.7	19.7	78	4.89	2.20	Single
7803-3B	Threaded,	1,200	600	16.00	21.9	7.44	10.2	41.7	19.7	78	6.39	2.86	Double
7804-3B	Plus 1/8" Sq. Key Drive	650	320	30.00	41.2	13.95	19.1	41.7	19.7	78	6.39	2.86	Double
7805-3B		350	170	55.00	75.5	26.25	36.0	41.7	19.7	78	6.39	2.86	Double

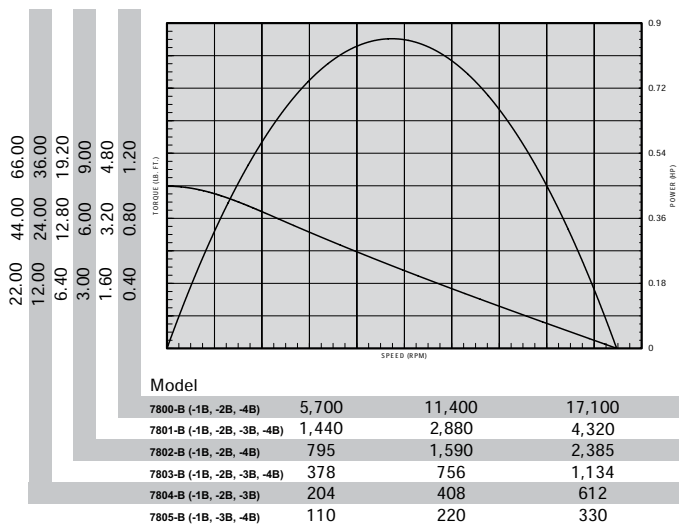

### Standard Equipment

Keyed and threaded spindle for shell end mills, metal-slitting saws and side-mill cutters, duplex bearing on drive spindle to provide maximum radial support. Also steel motor housing, flush-type grease fittings, exhaust manifold and muffler.

**NOTE: Key not furnished.**



### 2200-Series and Mounting Accessory Dimensions

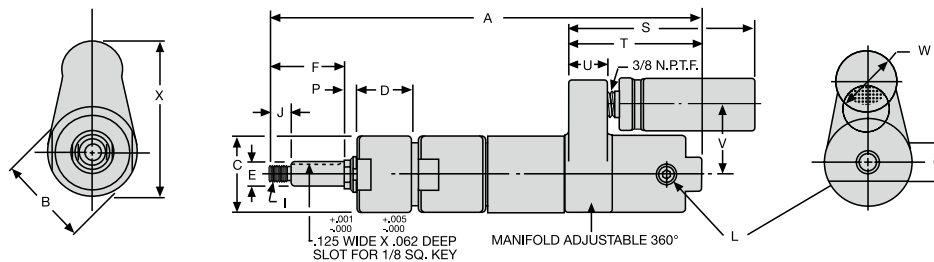

FORWARD ROTATION, DOUBLE REDUCTION SHOWN

Models	Gear Reduction	Dimension A
7800-3B 7801-3B 7802-3B	Single	9-1/2 241 mm
7803-3B 7804-3B 7805-3B	Double	11-9/32 286 mm

Scale	B	C	D	E	F	I	J	L
Inches	2	2.000 2.001	1.422 1.452	.6240 .6245	1.932 1.942	7/16-20 UNF-3A Thread	.552 .557	1/4 NPTF Air Inlet
mm	51	50.80 50.83	36.12 36.88	15.85 15.86	40.07 49.33		14.02 14.53	

Scale	O	P	S	T	U	V	W	X
Inches	7/8	.270 .380	4-7/8	3-1/2	1-1/16	1-13/16	1-3/8	3-1/2
mm	22	6.86 9.65	124	89	27	46	35	89



## 2200-Series Forward-Rotation Side Mount Milling Motors

### Specifications

MODEL	SPINDLE	R.P.M.		TORQUE		OUTPUT		AIR CONSUMPTION		SOUND LEVEL		WEIGHT		GEAR REDUCTION
		FREE SPEED	LOAD SPEED @MAX. H.P.	STALL lb. ft.	Nm	@MAX. H.P. lb. ft.	Nm	@FREE SPEED SCFM	L/s	@FREE SPEED dB(A)	lbs.	kg.		
<b>NON-REVERSIBLE - .85 H.P.</b>														
7800-4B	3/8"	18,000	9,000	1.00	1.4	.50	.68	41.7	19.7	78	4.89	2.20	Single	
7801-4B	Maximum	4,600	2,400	4.00	5.5	1.86	2.5	41.7	19.7	78	4.89	2.20	Single	
7802-4B	Collet	2,500	1,300	7.50	10.3	3.43	4.7	41.7	19.7	78	4.89	2.20	Single	
7803-4B	Capacity	1,200	600	16.00	21.9	7.44	10.2	41.7	19.7	78	6.39	2.86	Double	
7805-4B		350	170	55.00	75.5	26.25	36.0	41.7	19.7	78	6.39	2.86	Double	

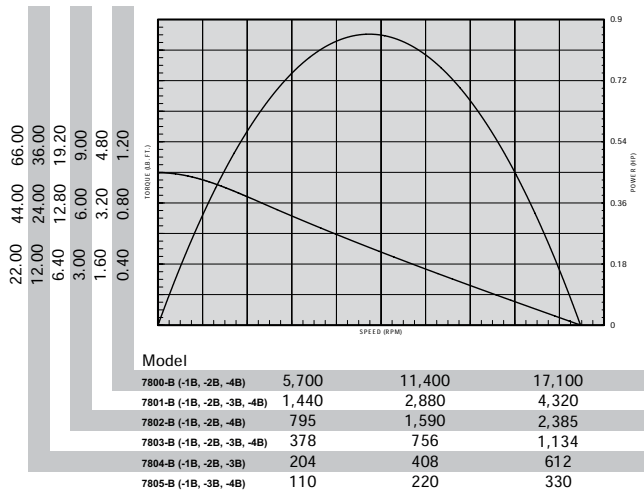

### Standard Equipment

Integral collet spindle and mounting head with 4 tapped holes for close-quarter mounting. Other standard equipment same as for motors on page 66.

### Equipment Options

For filter-regulator-lubricator, see listing on page 86.

### 2200-Series and Mounting Accessory Dimensions

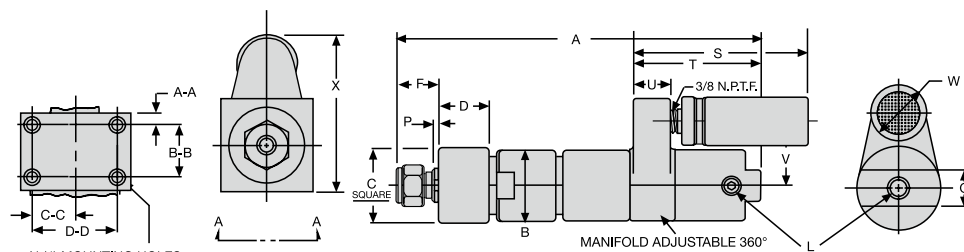

FORWARD ROTATION, DOUBLE REDUCTION SHOWN

Models	7800-4B	7801-4B	7802-4B	7803-4B	7804-4B	7805-4B	Gear Reduction	Dimension A
							Single	8-3/8 213 mm
							Double	10-3/16 259 mm

Scale	B	C	D	F	L	N	O	P	S
Inches	2	2.115 2.135	1.422 1.452	1-5/32 (Approx.)	1/4 NPTF	1/4-28 UNF-2B Thread 3/8" Deep	7/8	.097 .157	4-7/8
mm	51	53.72 54.23	36.12 36.88	29 (Approx.)	Air Inlet		22	2.46 3.99	124

Scale	T	U	V	W	X	A-A	B-B	C-C	D-D
Inches	3-1/2	1-1/16	1-13/16	1-3/8	3-9/16	.213 .223	1.000 1.005	.807 .817	1.62 1.63
mm	89	27	46	35	90	5.41 5.66	25.40 25.53	20.50 20.75	41.15 41.40

## 44-Series Forward-Rotation Milling Motors

### Specifications

MODEL	SPINDLE	R.P.M.		TORQUE				AIR		SOUND LEVEL		WEIGHT		GEAR REDUCTION
		FREE SPEED	LOAD SPEED @MAX. H.P.	STALL lb. ft.	Nm	OUTPUT @MAX. H.P. lb. ft.	Nm	CONSUMPTION @FREE SPEED SCFM	L/s	@FREE SPEED dB(A)	lbs.	kg.		
<b>NON-REVERSIBLE - 2.0 H.P.</b>														
8200-4A-( )	3/4" Maximum Collet Capacity	275	140	124.00	168.0	75.00	101.6	95.0	44.8	80	18.24	8.20	Double	
8201-4A-( )		500	255	70.50	95.5	41.00	55.5	95.0	44.8	80	18.24	8.20	Double	
8202-4A-( )		900	445	40.50	54.9	24.00	32.5	95.0	44.8	80	18.24	8.20	Double	
8203-4A-( )		2,000	1,050	18.00	24.4	10.00	13.5	95.0	44.8	80	13.82	5.21	Single	
8204-4A-( )		3,500	1,740	10.20	13.8	6.00	8.1	95.0	44.8	80	13.82	5.21	Single	
8205-4A-( )	14,000	7,000	2.85	3.9	1.50	2.0	95.0	44.8	80	13.82	5.21	Single		

Collet Insert No.	Dash No.	Size	Minimum Capacity		Maximum Capacity		Collet Insert No.	Dash No.	Size	Minimum Capacity		Maximum Capacity	
			Inches	mm	Inches	mm				Inches	mm	Inches	mm
35264-1	-A	1/4"	.2187	5.56	.2500	6.35	35264-10	-K	17/32"	.5000	12.70	.5312	13.49
35264-2	-B	9/32"	.2500	6.35	.2812	7.14	35264-11	-L	9/16"	.5312	13.49	.5625	14.29
35264-3	-C	5/16"	.2812	7.14	.3125	7.94	35264-12	-M	19/32"	.5625	14.29	.5937	15.08
35264-4	-D	11/32"	.3125	7.94	.3437	8.73	35264-13	-N	5/8"	.5937	15.08	.6250	15.88
35264-5	-E	3/8"	.3437	8.73	.3750	9.53	35264-14	-P	21/32"	.6250	15.88	.6562	16.67
35264-6	-F	13/32"	.3750	9.53	.4062	10.32	35264-15	-Q	11/16"	.6562	16.67	.6875	17.46
35264-7	-G	7/16"	.4062	10.32	.4375	11.11	35264-16	-R	23/32"	.6875	17.46	.7187	18.26
35264-8	-H	15/32"	.4375	11.11	.4687	11.91	35264-17	-S	3/4"	.7187	18.26	.7500	19.05
35264-9	-J	1/2"	.4687	11.91	.5000	12.70							

#### Approx. Tooling Penetration - 2 7/16" (62 mm)

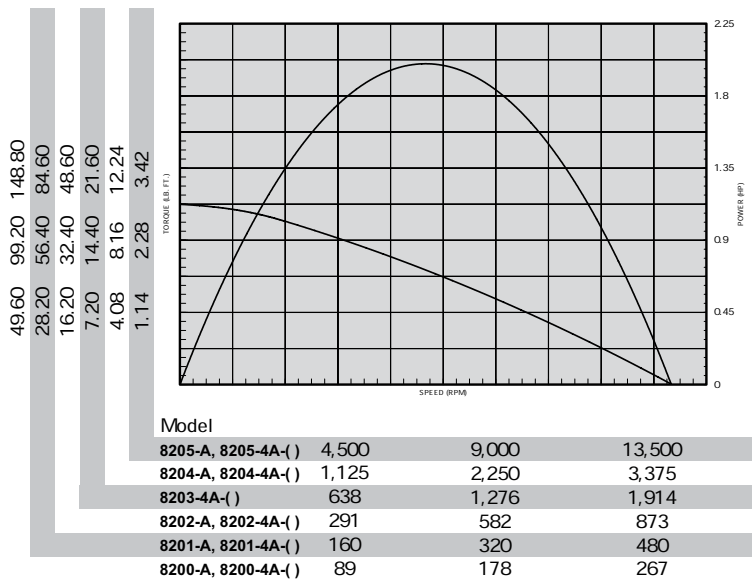

### Standard Equipment

Steel motor housing, flush-type grease fittings at rotation points for gear and bearing lubrication, exhaust manifold rotatable within 360°, muffler, integral collet spindle with 35264-17 3/4" capacity for end mills and Woodruff key slot cutters, duplex bearing on drive spindle for maximum radial support.



### No Cost Option

Another size collet insert may be substituted for the standard 3/4" capacity insert. Specify collet insert 35264-( ) in the desired size from the chart above.

### Equipment Options

45090 Foot Bracket

41557 Flange Bracket

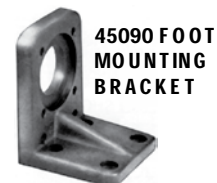

**45090 FOOT MOUNTING BRACKET**



**41557 FLANGE MOUNTING BRACKET**

## 44-Series Milling Motors and Mounting Accessory Dimensions

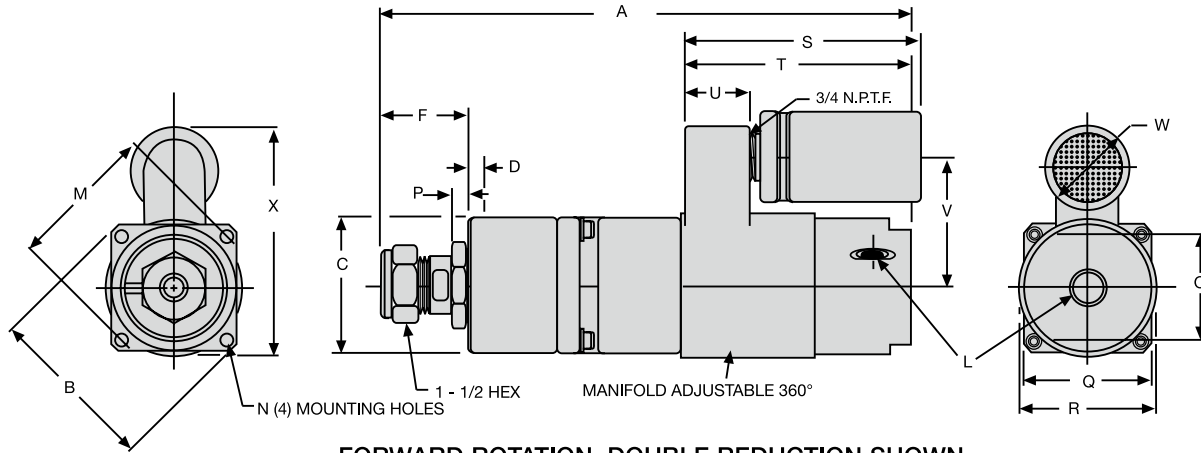

FORWARD ROTATION, DOUBLE REDUCTION SHOWN

Models			Gear Reduction	Dimension A
8203-4A	8204-4A	8205-4A	Single	11-11/16 297 mm
8200-4A	8201-4A	8202-4A	Double	14-1/2 368 mm

Scale	B	C	D	F	L	M	N	O	P
Inches	4.090 4.110	2.996 2.998	.302 .322	1-15/16 (Approx.)	3/8 NPTF	3.498 3.502	5/16-24 UNF-2B	2-1/2	.335 .364
mm	103.89 104.39	76.10 76.15	7.67 8.18	49 (Approx.)	Air Inlet	86.56 88.95	Thread	63	8.51 9.25

Scale	Q	R	S	T	U	V	W	X
Inches	3	3-3/16	5-3/16	5	1-7/16	2-27/32	2	5-7/16
mm	76	81	132	127	36	72	51	138

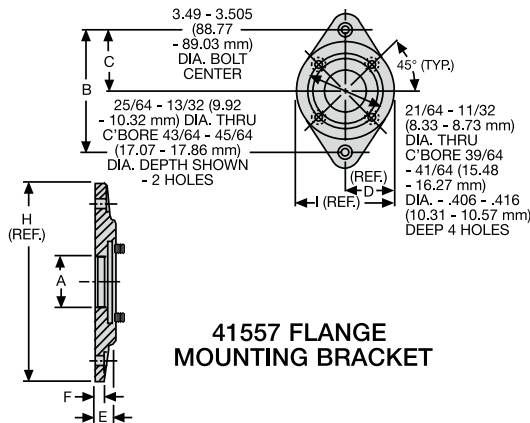

41557 FLANGE MOUNTING BRACKET

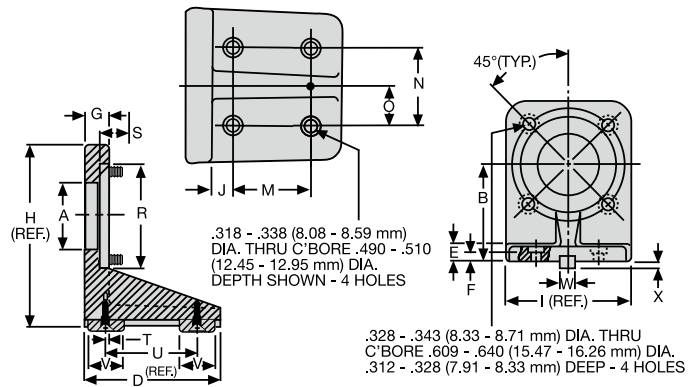

45090 FOOT MOUNTING BRACKET

Scale	A	B	C	D
Inches	1.927 1.947	5.745 5.755	2.870 2.880	2-1/4
mm	48.95 49.45	145.92 146.18	72.90 73.15	57.15

Scale	A	B	D	E	F	G	H	I	J	M
Inches	1.927 1.947	3.124 3.126	4	.468 .531	.296 .328	.671 .703	5-1/8	4	.546 .578	1.995 2.005
mm	55.12 60.20	79.35 79.40	101.6	11.89 13.49	7.52 8.33	17.04 17.78	130.18	101.6	13.87 14.68	50.67 50.93

Scale	E	F	H	I
Inches	.708 .728	.365 .385	7-1/4	4-1/2
mm	17.98 18.49	9.27 9.78	184.15	114.3

Scale	N	O	R	S	T	U	V	W	X
Inches	1.995 2.005	.995 1.005	2.999 3.000	.833 .853	.046 .078	2.609 2.640	.985 1.015	.499 .500	.173 .198
mm	50.67 50.93	25.27 25.53	76.17 76.20	21.16 21.67	1.17 1.98	66.27 67.06	25.02 25.78	12.674 12.700	4.39 5.03

# Specially Governed Motors

## Model 22N51-W/RC Multi-Vane Air Motors

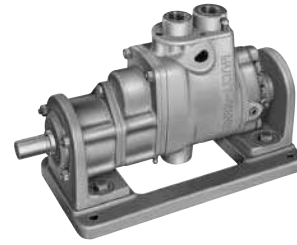

### Specifications

Model	Max. Power		Speed at Max. Power	Free Speed	Starting Torque		Stall Torque		Air Consumption at Max. Power		Weight	
	hp	kw	rpm	rpm	lb.-ft.	Nm	lb.-ft.	Nm	scfm	m <sup>3</sup> /m	lb.	kg
Reversible												
22N51-W/RC	1.75	1.31	208	280	49	66.4	66	89.5	55	1.6	21	9.5

Performance figures are at 90 psig (620 kPa) air pressure.

### Specifications

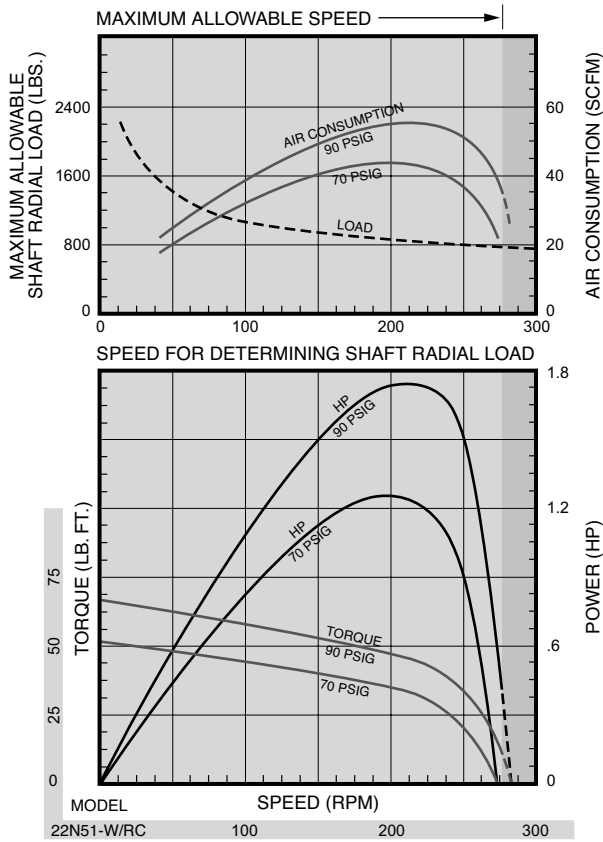

### Dimensions

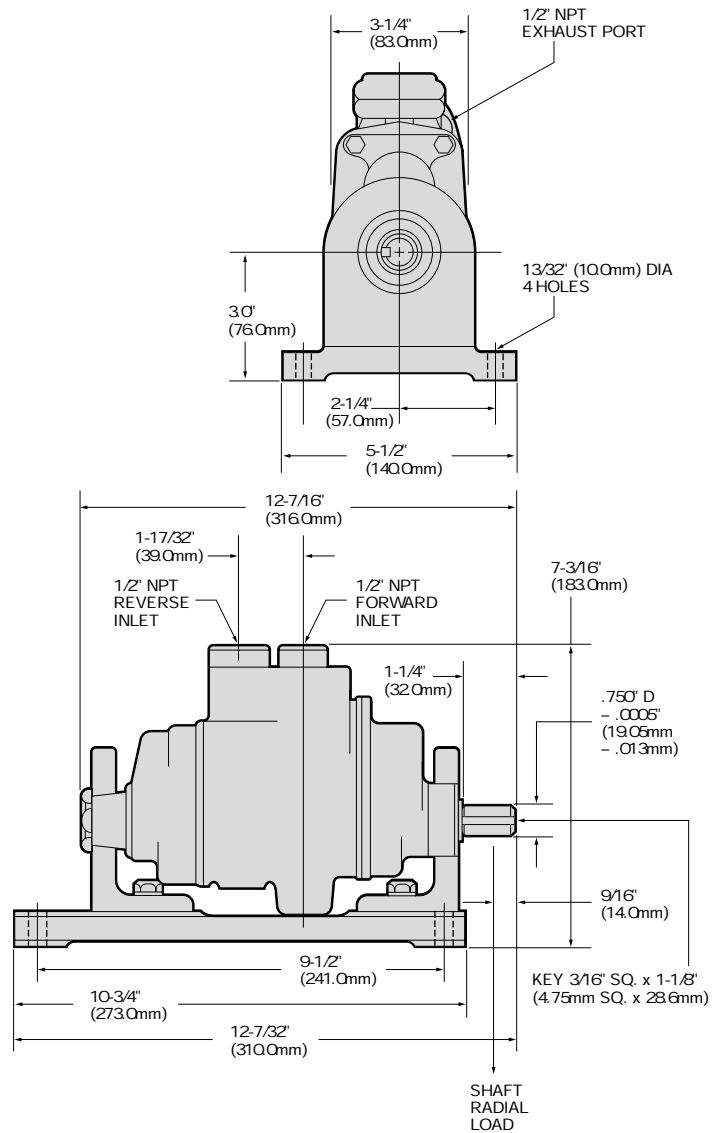

## Series 551 Multi-Vane Air Motors

### Specifications

Model	Max. Power		Speed at Max. Power	Free Speed▲	Starting Torque		Stall Torque		Air Consumption at Max. Power		Weight	
	hp	kw	rpm	rpm	lb.-ft.	Nm	lb.-ft.	Nm	scfm	m <sup>3</sup> /m	lb.	kg
<b>Reversible</b>												
551SM51-W/RC	5.6	4.18	95	120	400	542	545	739	160	4.53	93	42.2
551SO51-W/RC	5.6	4.18	59	77	650	881	885	1200	160	4.53	93	42.2

▲ ALL models must be operated with sufficient load to prevent speed from exceeding maximum allowable speed shown on performance curve. Performance figures are at 90 psig (620 kPa) air pressure.

### Specifications

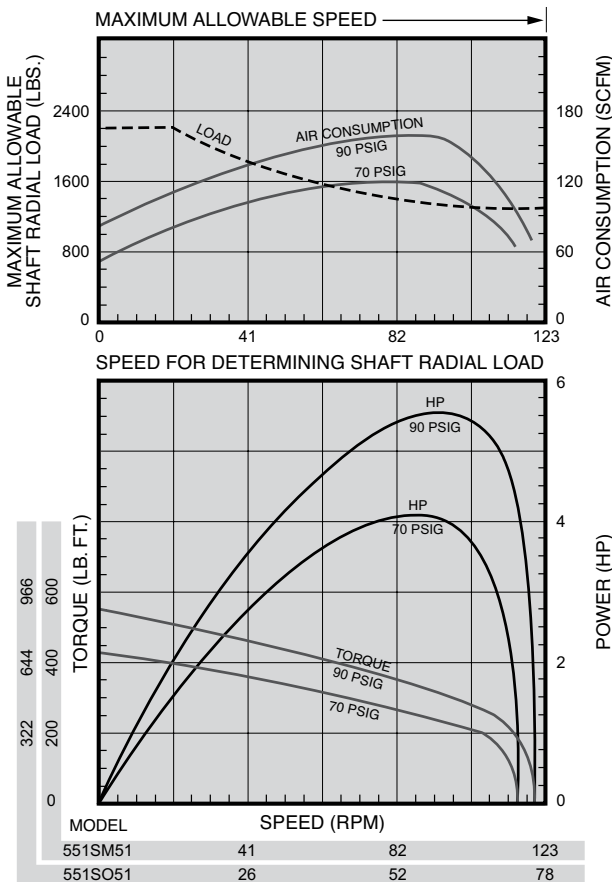

### Dimensions

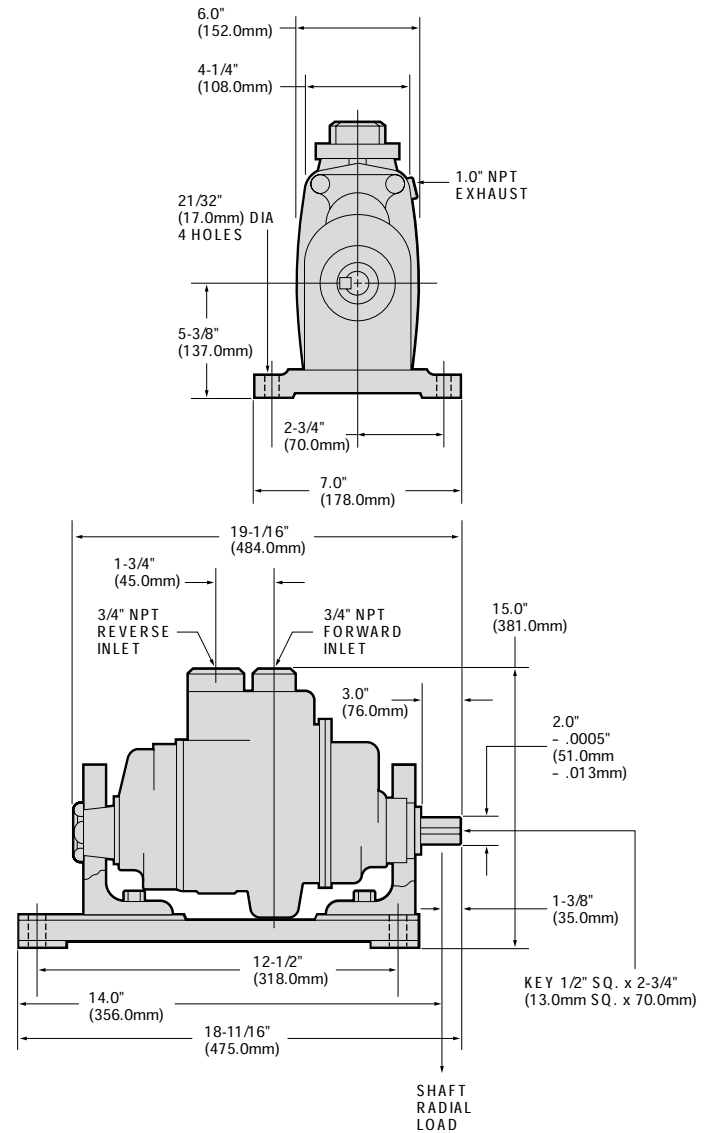

## Direct and Geared Drive Piston Air Motors Specifications

Model	Max. Power		Speed at Max. Power	Free Speed ▲	Starting Torque		Stall Torque		Air Consumption at Max. Power		Weight	
	hp	kw	rpm	rpm	lb.-ft.	Nm	lb.-ft.	Nm	scfm	m <sup>3</sup> /m	lb.	kg
<b>Direct Drive Reversible</b>												
CCM	2.05	1.53	1075	2140	13.2	17.9	18.8	25.5	97	2.7	135	61.2
DD6M	2.6	1.94	750	1490	24	32.5	34.2	46.4	79	2.2	135	61.2
EEM	4.4	3.28	735	1450	41	55.6	59	80	137	3.9	200	90.7
EE5M	7.8	5.82	950	1875	60	81.4	80.5	109.2	220	6.2	210	95.3
HHM	11.3	8.43	730	1450	106	144	152	206	270	7.6	235	107
HH5M	15.2	11.33	750	1500	146	198	195	264	400	11.3	250	113
KK6M	25	18.64	755	1500	260	353	325	441	680	19.3	475	216
<b>Geared Drive Reversible</b>												
EE3G	5	3.73	275	560	122	165	175	237	155	4.4	200	90.7
EE53G	6.8	5.07	305	600	154	209	205	278	220	6.2	220	99.8
EE9G	4.7	3.51	92	190	357	484	510	692	155	4.4	210	95.3
EE59G	6.5	4.85	100	200	450	610	600	814	220	6.2	230	104

▲ ALL models must be operated with sufficient load to prevent speed from exceeding maximum allowable speed shown on performance curve.  
 All of the above motors are furnished less valve and piping as standard.  
 Performance figures are at 90 psig (620 kPa) air pressure.

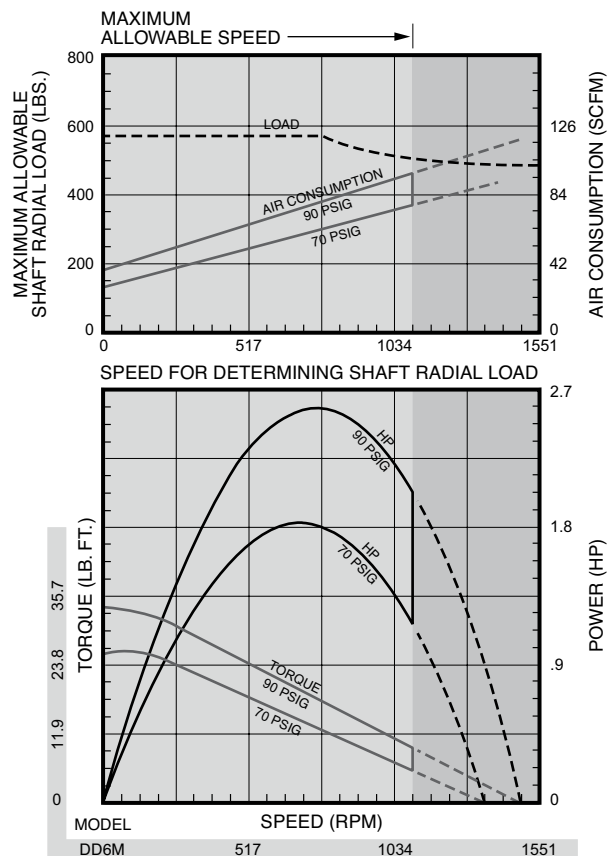
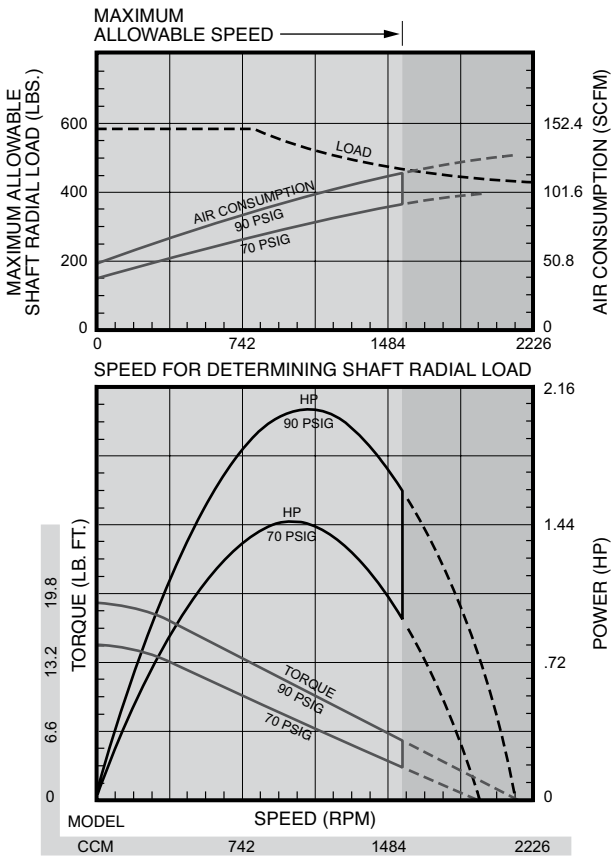



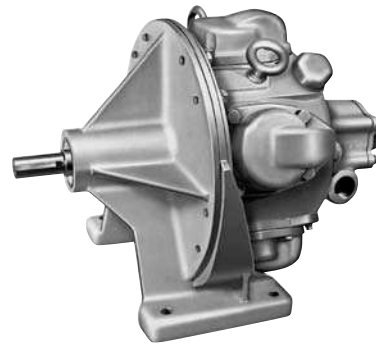
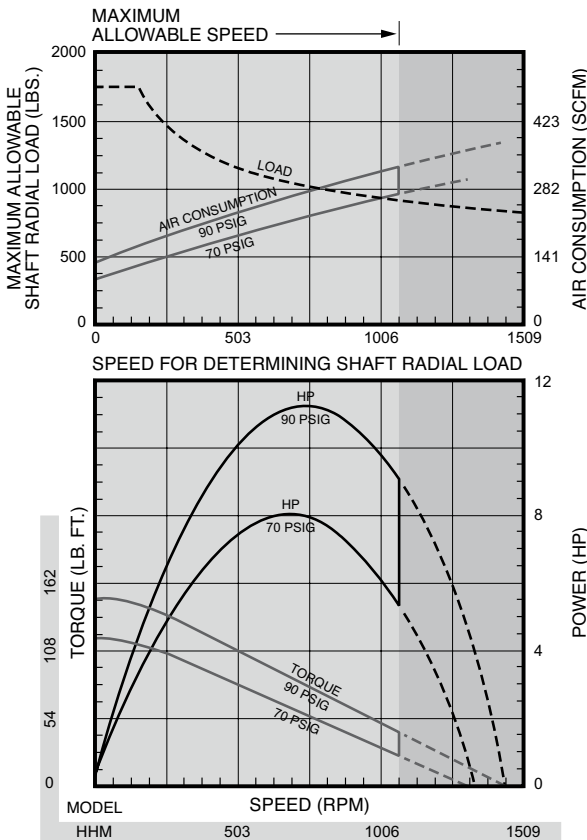
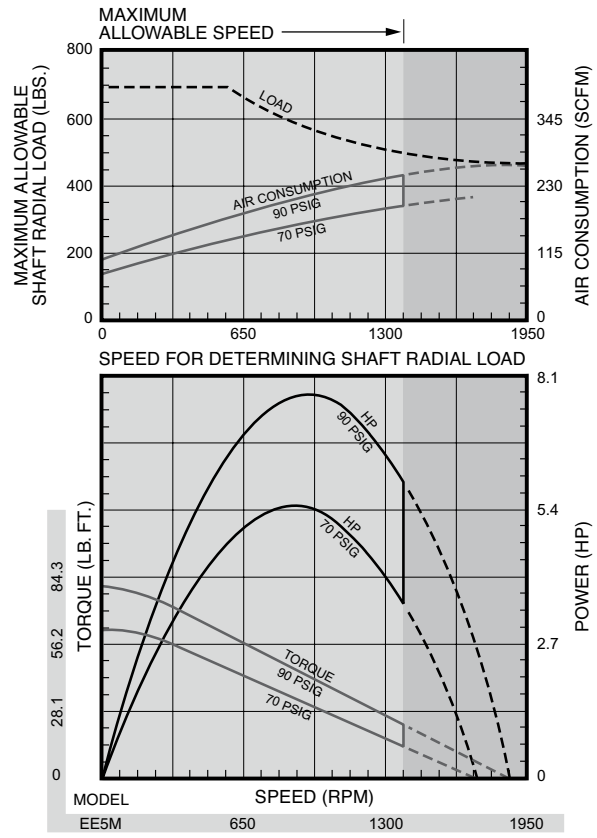
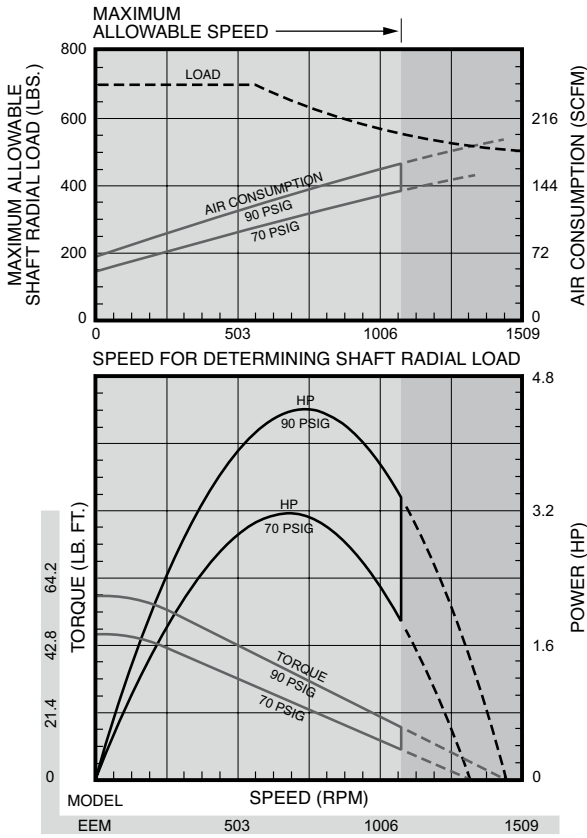

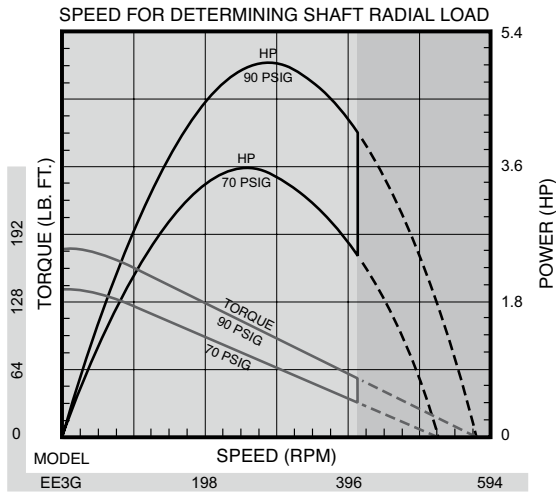
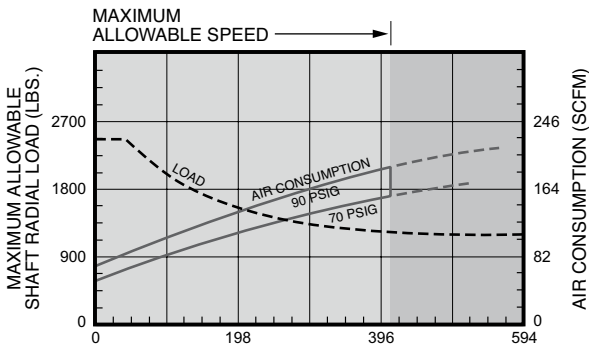
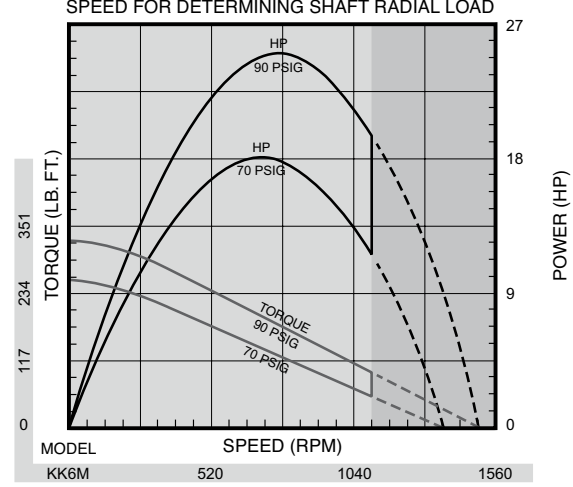
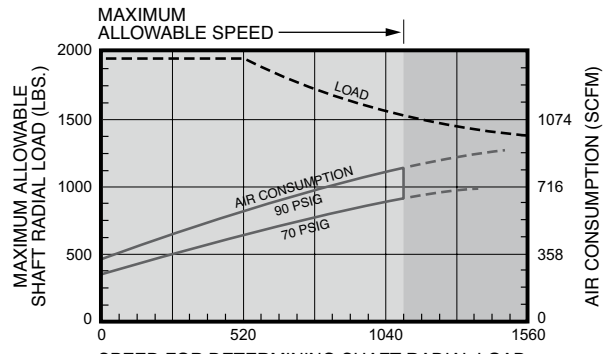
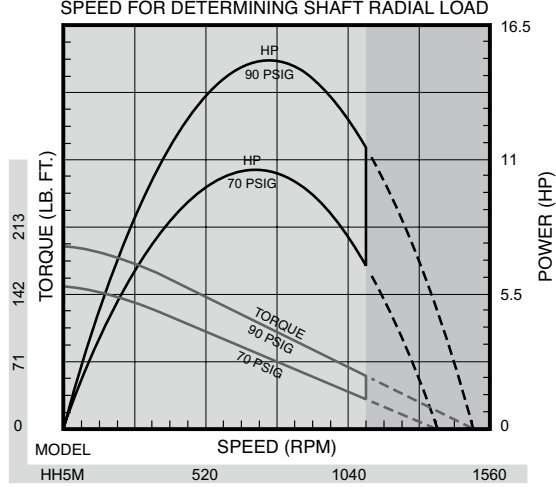
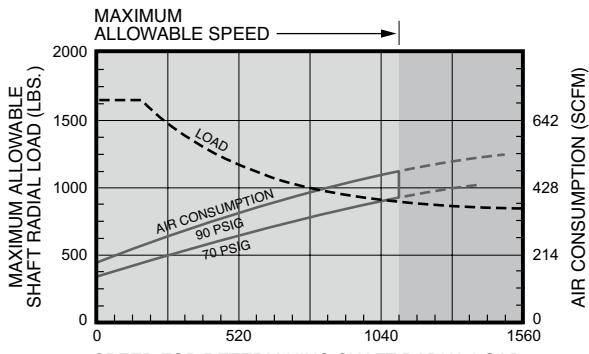

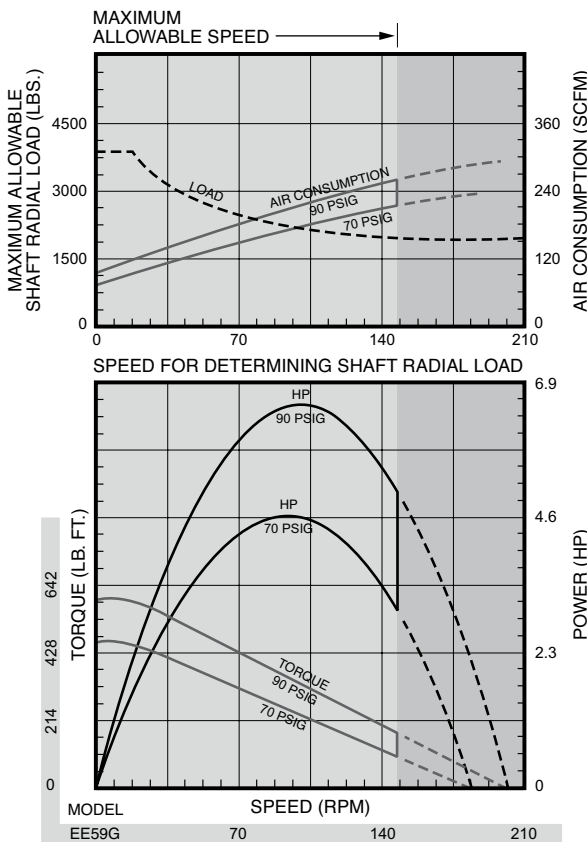
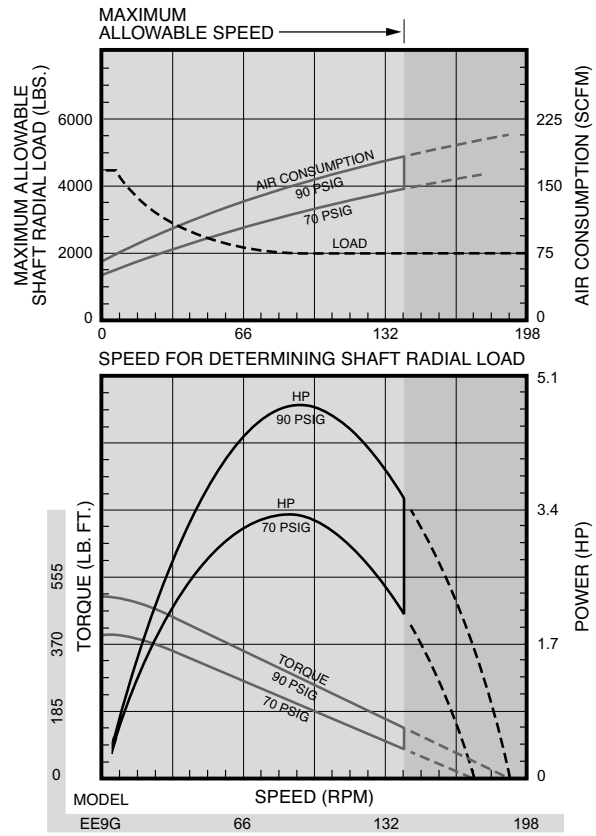
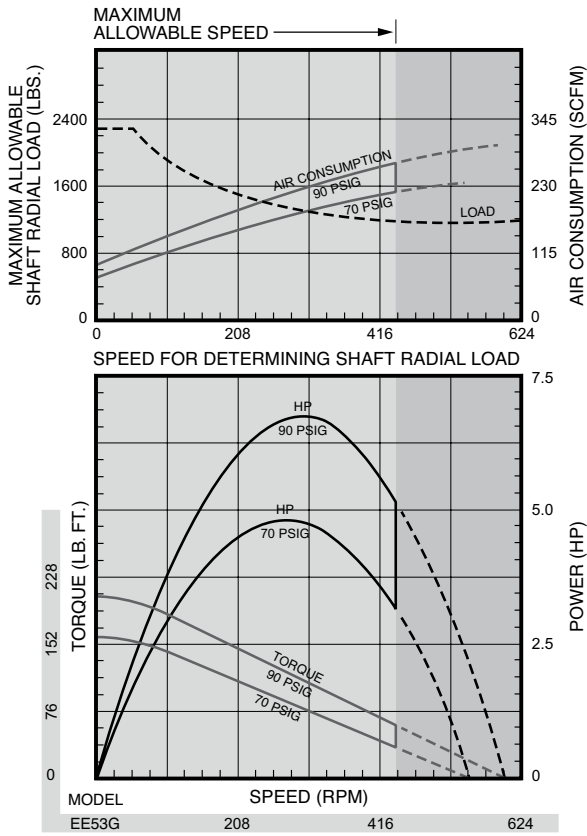

## Direct Drive Piston Air Motors

### Dimensions

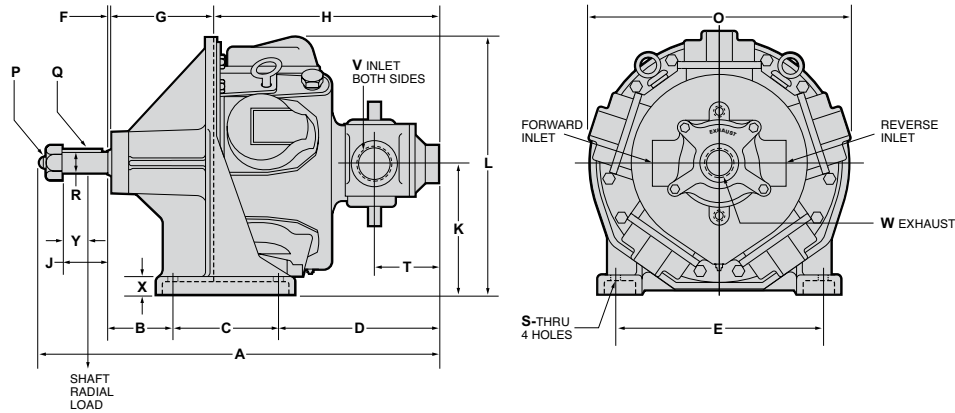

### Dimensions in Inches

Model	A	B	C	D	E	F	G	H	J	K	L	O	P** Thd.	Q Key	R*	S Dia.	T	V NPT	W NPT	X	Y
CCM, DD6M	23 <sup>3</sup> / <sub>16</sub>	3 <sup>3</sup> / <sub>16</sub>	7 <sup>3</sup> / <sub>16</sub>	7 <sup>7</sup> / <sub>16</sub>	10 <sup>1</sup> / <sub>2</sub>	2 <sup>5</sup> / <sub>32</sub>	7 <sup>1</sup> / <sub>32</sub>	11 <sup>3</sup> / <sub>16</sub>	3	8 <sup>3</sup> / <sub>16</sub>	15 <sup>15</sup> / <sub>16</sub>	13 <sup>3</sup> / <sub>4</sub>	1"-8	1/4 x 1/4	1.125	2 <sup>29</sup> / <sub>32</sub>	2 <sup>1</sup> / <sub>16</sub>	3/4	1	7/8	2 <sup>1</sup> / <sub>16</sub>
EEM, EE5M	27	3 <sup>1</sup> / <sub>16</sub>	9 <sup>3</sup> / <sub>16</sub>	9 <sup>9</sup> / <sub>32</sub>	12 <sup>1</sup> / <sub>2</sub>	2 <sup>5</sup> / <sub>32</sub>	9 <sup>1</sup> / <sub>32</sub>	12 <sup>1</sup> / <sub>32</sub>	3	9 <sup>9</sup> / <sub>16</sub>	16 <sup>1</sup> / <sub>16</sub>	15	1"-8	1/4 x 1/4	1.125	2 <sup>29</sup> / <sub>32</sub>	2 <sup>1</sup> / <sub>16</sub>	1	1	7/8	2 <sup>1</sup> / <sub>16</sub>
HHM	24 <sup>3</sup> / <sub>16</sub>	4 <sup>3</sup> / <sub>16</sub>	7	9 <sup>3</sup> / <sub>16</sub>	13 <sup>1</sup> / <sub>2</sub>	3 <sup>1</sup> / <sub>16</sub>	7	14	3	8 <sup>3</sup> / <sub>16</sub>	17 <sup>1</sup> / <sub>4</sub>	17 <sup>1</sup> / <sub>4</sub>	+	3/8 x 3/8	1.375	2 <sup>29</sup> / <sub>32</sub>	3 <sup>1</sup> / <sub>16</sub>	1	1 <sup>1</sup> / <sub>4</sub>	1 <sup>1</sup> / <sub>4</sub>	1 <sup>1</sup> / <sub>16</sub>
HH5M	24 <sup>3</sup> / <sub>16</sub>	4 <sup>3</sup> / <sub>16</sub>	7	9 <sup>3</sup> / <sub>16</sub>	13 <sup>1</sup> / <sub>2</sub>	3 <sup>1</sup> / <sub>16</sub>	7	14	3	8 <sup>3</sup> / <sub>16</sub>	17 <sup>1</sup> / <sub>4</sub>	17 <sup>1</sup> / <sub>4</sub>	+	3/8 x 3/8	1.375	2 <sup>29</sup> / <sub>32</sub>	3 <sup>1</sup> / <sub>16</sub>	1	1 <sup>1</sup> / <sub>4</sub>	1 <sup>1</sup> / <sub>4</sub>	1 <sup>1</sup> / <sub>16</sub>
KK6M	30 <sup>3</sup> / <sub>16</sub>	4 <sup>3</sup> / <sub>16</sub>	8 <sup>3</sup> / <sub>16</sub>	12 <sup>1</sup> / <sub>2</sub>	13 <sup>1</sup> / <sub>2</sub>	1/2	7 <sup>1</sup> / <sub>16</sub>	18 <sup>3</sup> / <sub>16</sub>	4 <sup>1</sup> / <sub>2</sub>	12 <sup>1</sup> / <sub>2</sub>	22 <sup>1</sup> / <sub>4</sub>	22	+	3/8 x 3/8	1.625	2 <sup>29</sup> / <sub>32</sub>	4 <sup>3</sup> / <sub>16</sub>	1 <sup>1</sup> / <sub>4</sub>	1 <sup>1</sup> / <sub>2</sub>	1 <sup>1</sup> / <sub>2</sub>	1 <sup>1</sup> / <sub>2</sub>

+ The end of the shaft is not threaded on these Motors and no nut is used. \*Tolerance: +0 -.0005" \*\*Thd.-UNC2A.

### Dimensions in Millimeters

Model	A	B	C	D	E	F	G	H	J	K	L	O	P Thd.	Q Key	R*	S Dia.	T	X	Y
CCM, DD6M	599	95	197	200	267	20	188	284	76	222	397	349	1"-8	6 x 6	28	20	68	22	68
EEM, EE5M	686	97	248	236	318	20	242	318	76	237	427	381	1"-8	6 x 6	28	20	75	22	68
HHM	614	110	178	251	343	5	178	356	76	225	438	438	+	10 x 10	35	17	97	32	33
HH5M	614	110	178	251	343	5	178	356	76	225	438	438	+	10 x 10	35	17	97	32	33
KK6M	768	121	219	321	343	3	195	462	108	308	565	559	+	10 x 10	41	17	110	35	48

+ The end of the shaft is not threaded on these Motors and no nut is used. \*Tolerance: +0 -0.13mm

## Geared Drive Piston Air Motors

### Dimensions

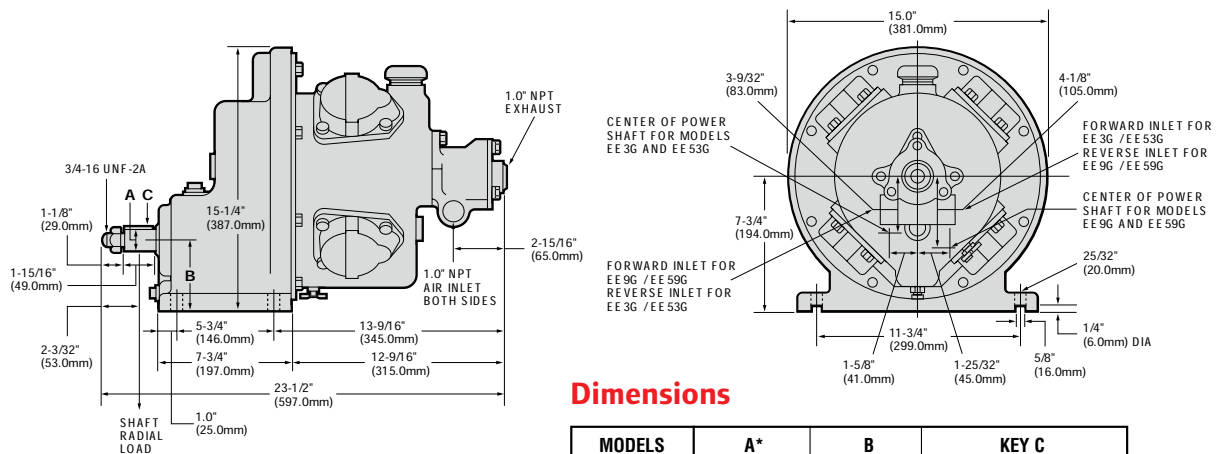

### Dimensions

MODELS	A*		B		KEY C	
	in.	mm	in.	mm	in.	mm
EE3G, EE53G	1.251	31.78	4 <sup>1</sup> / <sub>2</sub>	114	1/4 x 1/4 x 1 <sup>2</sup> / <sub>16</sub>	6 x 6 x 45
EE9G, EE59G	1.501	38.13	3 <sup>3</sup> / <sub>8</sub>	92	3/8 x 3/8 x 1 <sup>1</sup> / <sub>16</sub>	10 x 10 x 43

\*Tolerance: +0 -.0005" (0.13mm)

## MMP150 Air Motors

### Model Code Explanation

Example: MMP150-A-0-B-2-A

Series: **MMP150 Air Motor**

Interface/Shaft Options:

- A = **Standard Spline**
- D = **Keyed Shaft (Fenner RM410)**

Mounting Options:

- 0 = **Standard**
- 1 = **Base Mount**

Control Options:

- A = **None**
- B = **Manual Valve**
- C = **Panel Mount Valve**
- D = **Pendant**
- E = **Accu-Trol™**

Rotary Valve Bias Options:

- 1 = **CCW (counter-clockwise), Standard Bias Rotation\***
- 2 = **CW (clockwise), Reverse Bias Rotation\***

Power Options:

- A = **Air**
- B = **Natural Gas**

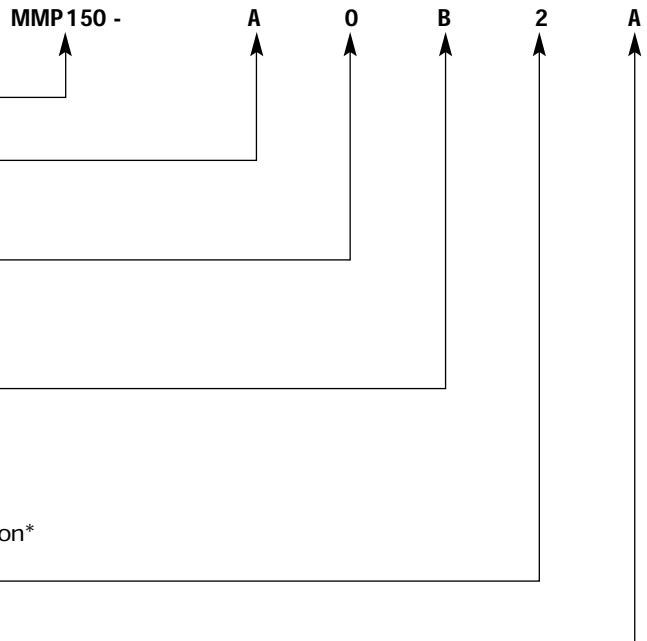

\*As viewed from crankshaft end of motor.

### Performance

Model	Max. Power		Speed at Max. Power	Free Speed	Starting Torque		Stall Torque		Air Consumption at Max. Power	
	hp	kw	rpm	rpm	lb.-ft.	Nm	lb.-ft.	Nm	scfm	m³/m
MMP150	16.0	11.9	1800	3800	61.0	82.7	78.0	105.8	425	12.0

Performance figures are at 90 psig (6.2 Bar) air pressure.

Figure 1: MMP150 Air Motor Performance  
425 cfm Air Supply at 90 psi

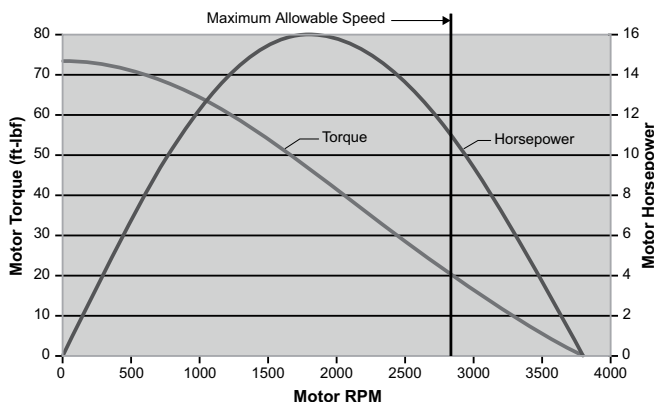
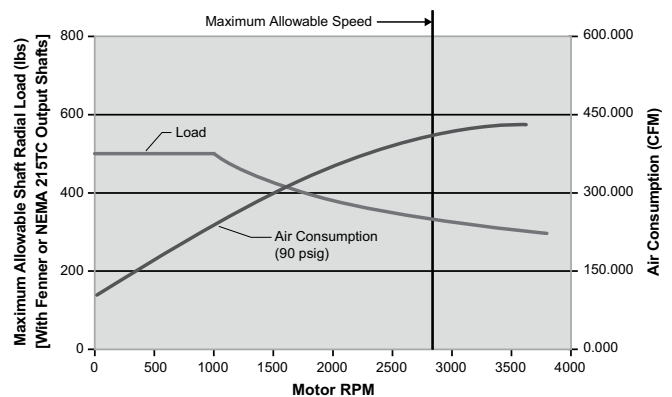
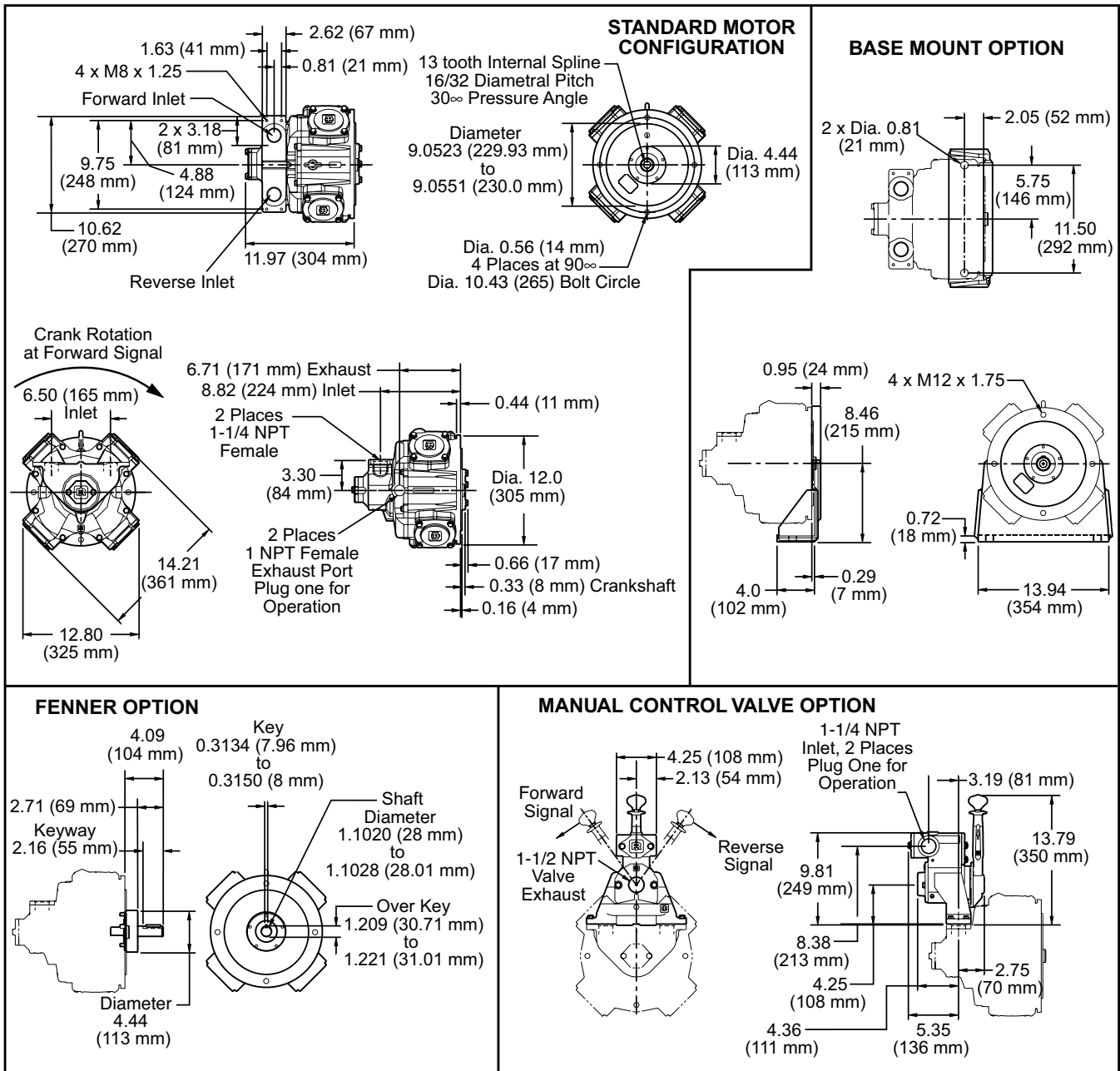

Figure 2: MMP150 Air Motor Performance







## KK5B Piston Air Motors Specifications

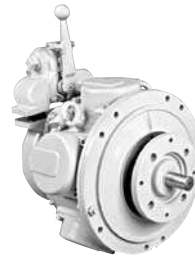

Model	Max. Power		Speed at Max. Power	Free Speed▲	Starting Torque		Stall Torque		Air Consumption at Max. Power		Weight	
	hp	kw	rpm	rpm	lb.-ft.	Nm	lb.-ft.	Nm	scfm	m <sup>3</sup> /m	lb.	kg
<b>Reversible</b>												
KK5B546	29	21.6	900	1800	183	248	300	407	795	22.5	—	—
KK5B550	30	22.3	880	1750	202	274	325	441	850	24.1	—	—

▲ ALL models must be operated with sufficient load to prevent speed from exceeding maximum allowable speed shown on performance curve. Performance figures are at 90 psig (620 kPa) air pressure.

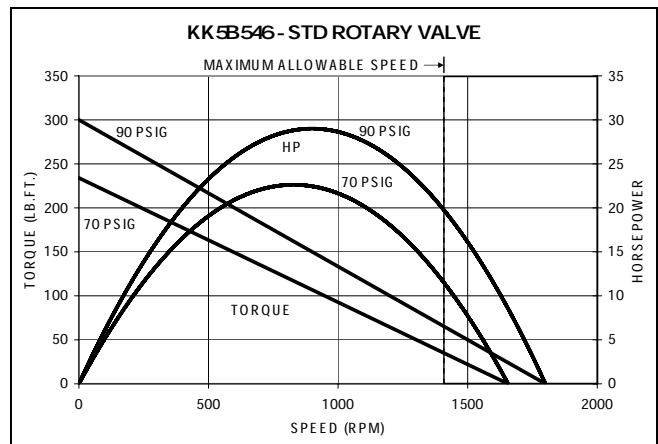
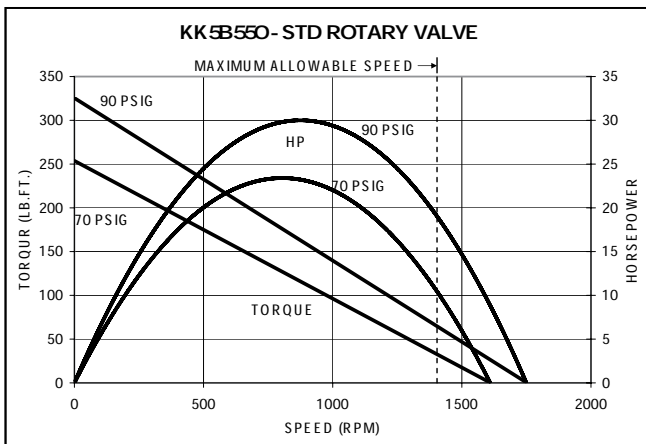
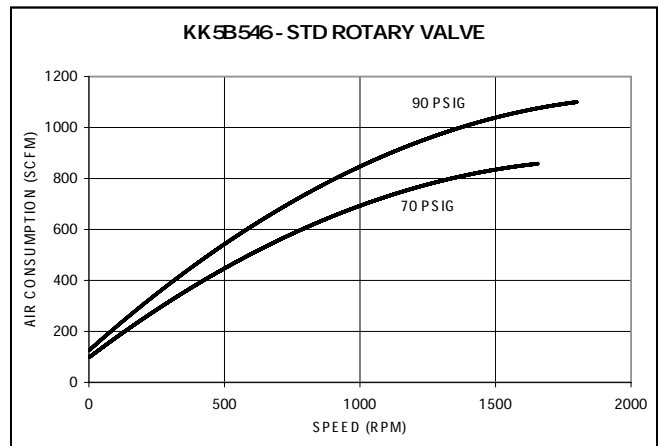
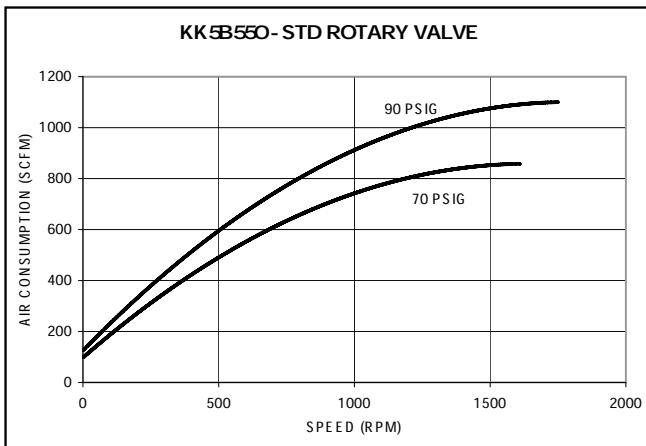

## KK5B Piston Air Motors

### Model Number Symbolization

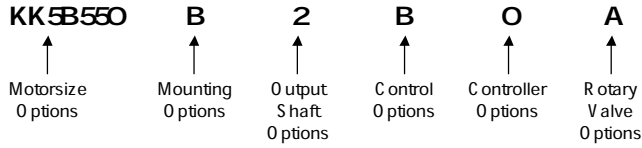

### Example

**KK5B550-B2BOA**

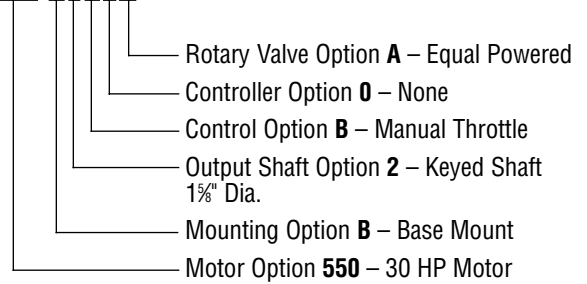

Option	Code	Description	Weight		Part Number
			lb.	kg	
Motor Options	546	29 Horsepower Motor	251	113	KK5B546
	550	30 Horsepower Motor	251	113	KK5B550
Mounting Options	A	Flange Mount, STD with SAE C 2 & 4 Bolt Mount	45	20	Standard
	B	Base Mount, Stationary Mounting			K5B - Foot
Output Shaft Options	0	*SAE C, STD with SAE C 14 Tooth Female Spline Input	13	6	Standard
	1	**NEMA 213TC and 215TC, Keyed Shaft 1 3/8" dia.			K5B - NEMA - 213
	2	***Keyed Shaft 1 3/8" dia.			K5B - Shaft - 1.625
Control Options	A	None	19	19	Standard
	B	Manual Throttle, Control Mounted Directly on Motor			K5B - Manual
	C	Pilot Air Control, Required for Remote Controller Options			K5B - Pilot
Controller Options	0	None	9	4	Standard
	1	Pendant Control, STD 2 Button Pendant			MLK-K269C
	2	Panel Control, Required for Remote Stationery Mounted Control			UWD - A686
Rotary Valve Options	A	Equal Powered			Standard
	B	Biased Powered CCW			POA
	C	Biased Powered CW			POA

\*Flange Gasket Required    \*\*Single Bearing Mount    \*\*\*Double Bearing Mount

### Example KK5B550 - B2A0A Arrangement

### KK5B Motor

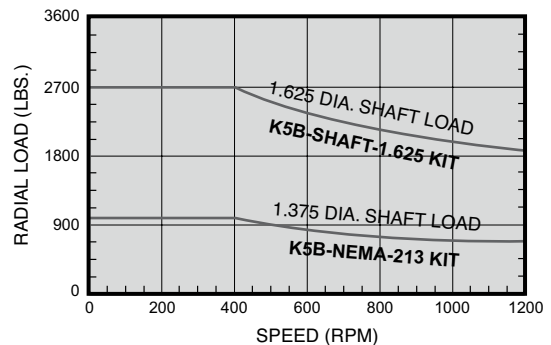
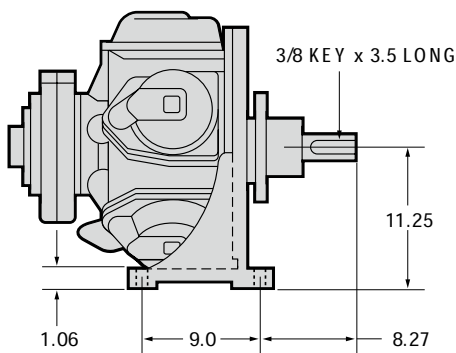

# KK5B Piston Air Motor

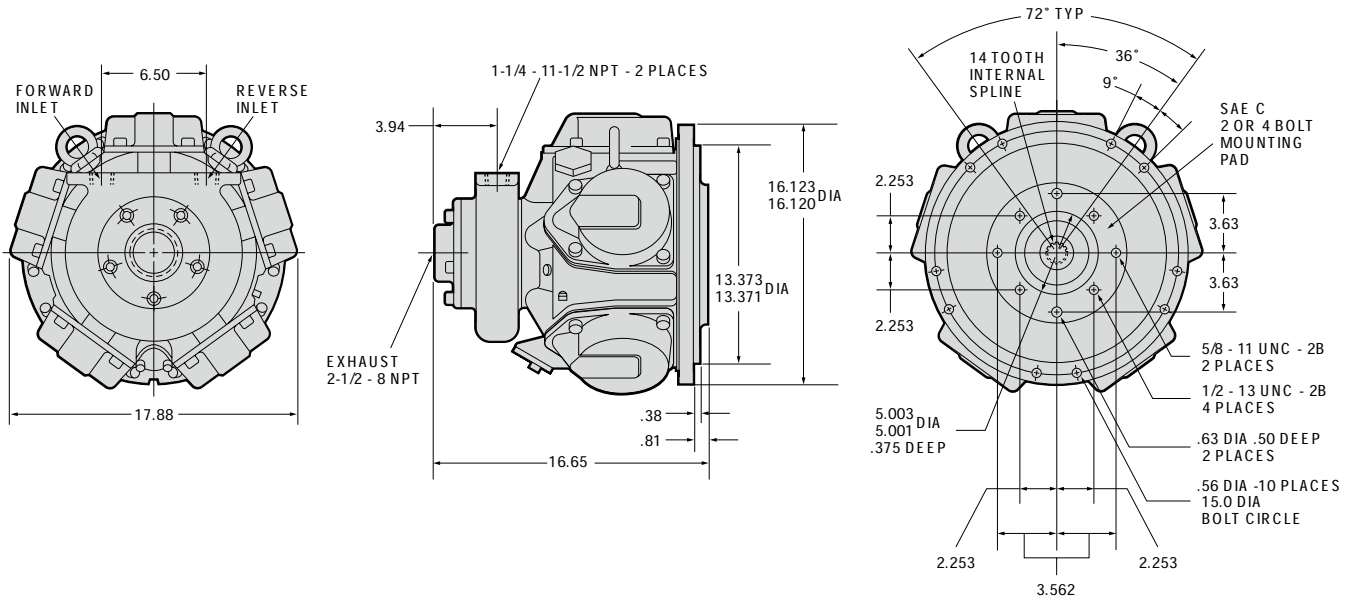

## Top and Side Views

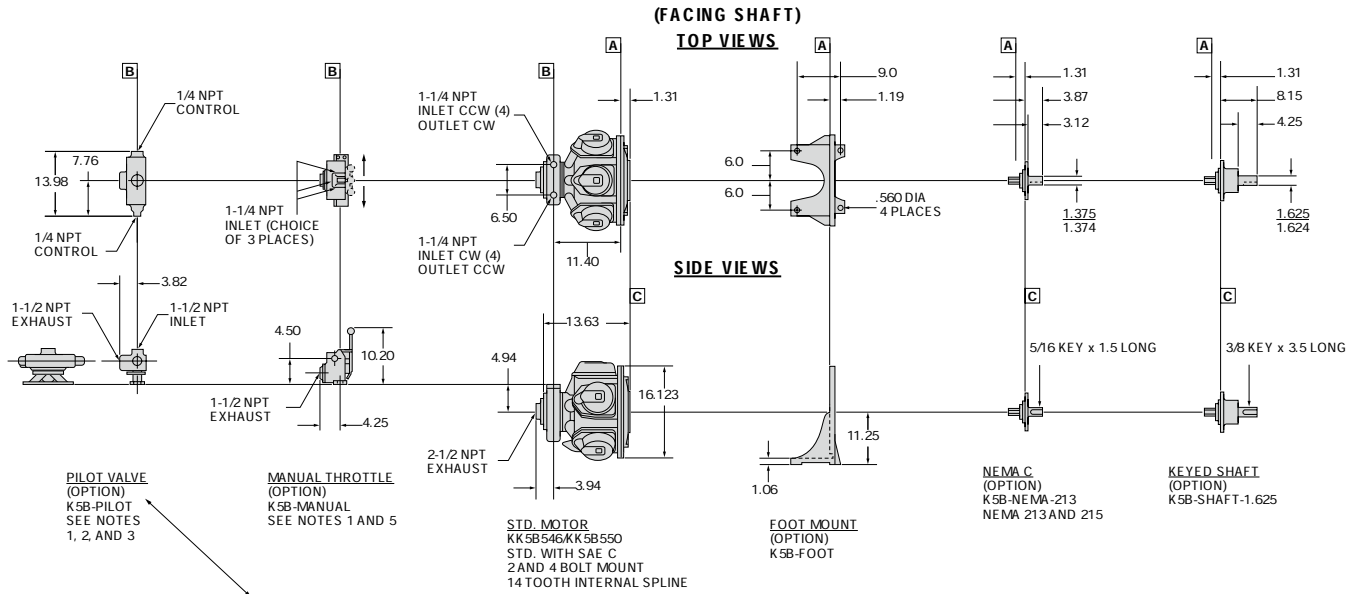

- 1) PERFORMANCE REDUCTION OF 20% - SAME STARTING AND STALL TORQUE BUT REDUCED HORSEPOWER AND FREE SPEED AS VALVING RESTRICTS MAX. AIR FLOW
- 2) FOR CONTROL LINE LENGTHS GREATER THAN 50 FT. AND FOR EVERY 50 FT. THEREAFTER, INSTALL TWO QUICK EXHAUST VALVES IN CONTROL LINES: MK-939-6, 1/4" ID HOSE
- 3) AIR PILOT CONTROLS GIVE GOOD CONTROL UP TO 100 FT. AS THE CONTROL LINES LENGTHEN, THE CONTROL RESPONSE DETERIORATES. ROUTE CONTROL LINES IN THE SHORTEST MANNER PRACTICAL
- 4) CW-CLOCKWISE ROTATION OF MOTOR LOOKING AT OUTPUT SHAFT OR SPLINE CCW-COUNTERCLOCKWISE ROTATION OF MOTOR LOOKING AT OUTPUT SHAFT OR SPLINE
- 5) THE MANUAL THROTTLE MAY BE REMOTELY MOUNTED UP TO 30 FT. AWAY USING EITHER 1-1/2" ID HOSE OR PIPE

## Components, Equipment and Accessories

### Filters, Regulators and Lubricators

Ingersoll Rand and ARO filters, regulators and lubricators give increased motor performance, reduce repair costs and extend motor life.

#### Filters

Motor Series	Motor Inlet Size	Part No.	NPT Size	Flow Rate scfm	Bowl Capacity oz.	Height in.	Width in.	Depth in.
M002, SM1AM, SM1UP	1/8"	F35121-420	1/4"	49	0.7	4.30	2.00	2.00
0, 2200, M004, M007, MOV005AA, SM2AM	1/4"	F35221-410	1/4"	73	1.20	6.00	2.30	2.30
SM4AM	1/4"	F35231-410	3/8"	107	1.20	6.00	2.30	2.30
1801, 1841	3/8"	F35331-410	3/8"	150	2.40	7.00	2.80	2.80
17RA, 17RB, MVA017	3/8"	F35341-410	1/2"	190	2.40	7.00	2.80	2.80
3800, 3840, 4800, 4840, 48RA, 48RB, 22N51-W/RC, SM6AM	1/2"	F35341-410	1/2"	190	2.40	7.00	2.80	2.80
SM8AM	1/2"	F35351-410	3/4"	211	2.40	7.00	2.80	2.80
34RA, 34RB, MVA034	1/2"	F35461-410	1"	297	5.30	10.75	3.60	3.90
551, CCM, DD6M	3/4"	F35451-410	3/4"	273	5.30	10.75	3.60	3.90
92RA, 92RB, 92RM, 992RM, EEM, EE5M, HHM, EE3G, EE9G, EE53G, EE59G	1"	F35461-410	1"	297	5.30	10.75	3.60	3.90
HH5M	1"	F42-0A-000	1-1/4"	860	13.00	14.90	8.50	8.50
KK6M, MMP150, MOV075AA	1-1/4"	F42-0A-000	1-1/4"	860	13.00	14.90	8.50	8.50
KK5B546, KK5B550	1-1/4"	F35-0B-C28	1-1/2"	1280	12.50	19.00	7.80	7.80



#### Regulators

Motor Series	Motor Inlet Size	Part No.	NPT Size	Flow Rate scfm	Adj. Pressure Range psi	Height in.	Width in.	Depth in.
M002, SM1AM, SM1UP	1/8"	R37121-600	1/4"	55	5 - 250	3.50	2.90	2.00
M004, M007, MOV005AA, SM2AM	1/4"	R37221-600	1/4"	73	5 - 250	4.75	2.20	2.70
SM4AM	1/4"	R37231-600	3/8"	84	5 - 250	4.75	2.20	2.70
1801, 1841	3/8"	R37331-600	3/8"	167	5 - 250	5.50	3.20	2.80
17RA, 17RB, MVA017	3/8"	R37341-600	1/2"	198	5 - 250	5.50	3.20	2.80
3800, 3840, 4800, 4840, 48RA, 48RB, 22N51-W/RC, SM6AM	1/2"	R37341-600	1/2"	198	5 - 250	5.50	3.20	2.80
34RA, 34RB, MVA034, SM8AM	1/2"	R37351-600	3/4"	200	5 - 250	5.50	3.20	2.80
551, CCM, DD6M	3/4"	R37451-600	3/4"	290	5 - 250	7.00	3.50	4.00
92RA, 92RB, 92RM, 992RM, EEM, EE5M, HHM, EE3G, EE9G, EE53G, EE59G	1"	R37461-600	1"	290	5 - 250	7.00	3.50	4.00
HH5M	1"	R30-0A-C00	1-1/4"	800	5 - 125	10.30	4.30	4.30
KK6M, MMP150, MOV075AA	1-1/4"	R30-0A-C01	1-1/4"	1200	5 - 125	10.30	4.30	4.30
KK5B546, KK5B550	1-1/4"	R40-0B-C00	1-1/2"	1200	5 - 125	11.90	5.30	5.30



#### Lubricators

Motor Series	Motor Inlet Size	Part No.	NPT Size	Flow Rate scfm	Bowl Capacity oz.	Height in.	Width in.	Depth in.
M002, SM1AM, SM1UP	1/8"	L36121-110	1/4"	57	0.50	5.00	2.00	2.00
M004, M007, MOV005AA, SM2AM	1/4"	L36221-110	1/4"	51	1.50	6.00	2.25	2.25
SM4AM	1/4"	L36231-110	3/8"	105	1.50	6.00	2.25	2.25
1801, 1841	3/8"	L36331-110	3/8"	85	4.00	7.70	2.75	2.90
17RA, 17RB, MVA017	3/8"	L36341-110	1/2"	156	4.00	7.70	2.75	2.90
3800, 3840, 4800, 4840, 48RA, 48RB, SM6AM, 22N51-W/RC	1/2"	L36341-110	1/2"	156	4.00	7.70	2.75	2.90
SM8AM	1/2"	L36351-110	3/4"	222	4.00	7.70	2.75	2.90
34RA, 34RB, MVA034	1/2"	L36461-110	1"	332	4.00	10.00	3.60	3.90
551, CCM, DD6M	3/4"	L36451-110	3/4"	368	4.00	10.00	3.60	3.90
92RA, 92RB, 92RM, 992RM, EEM, EE5M, HHM, EE3G, EE9G, EE53G, EE59G	1"	L36461-110	1"	332	4.00	10.00	3.60	3.90
HH5M	1"	L40-0A-000	1-1/4"	927	26.00	11.61	5.50	5.00
KK6M, MMP150, MOV075AA	1-1/4"	L40-0A-000	1-1/4"	927	26.00	11.61	5.50	5.00
KK5B546, KK5B550	1-1/4"	L40-0B-000	1-1/2"	927	26.00	11.61	5.50	5.00



## IR and ARO Combination FRLs (Filter / Regulator / Lubricator)

Motor Series	Motor Inlet Size	Part No.	NPT Size	Flow Rate scfm	Adj. Pressure Range psi	Bowl Capacity oz.	Height in.	Width in.	Depth in.
M002, SM1AM, SM1UP	1/8"	C38121-820	1/4"	46	5 - 250	FILTER = 0.4 LUBRICATOR = 0.4	5.20	4.75	3.20
M004, M007, MOV005AA, SM2AM	1/4"	C38221-810	1/4"	51	5 - 250	FILTER = 1.2 LUBRICATOR = 1.5	6.60	6.60	3.20
SM4AM	1/4"	C38231-810	3/8"	63	5 - 250	FILTER = 1.2 LUBRICATOR = 1.5	6.60	6.60	3.20
1801, 1841	3/8"	C38331-810	3/8"	99	5 - 250	FILTER = 2.4 LUBRICATOR = 3.7	7.70	8.70	3.60
17RA, 17RB, MVA017	3/8"	C38341-810	1/2"	150	5 - 250	FILTER = 2.4 LUBRICATOR = 3.7	7.70	8.70	3.60
3800, 3840, 22N51-W/RC	1/2"	C38341-810	1/2"	150	5 - 250	FILTER = 2.4 LUBRICATOR = 3.7	7.70	8.70	3.60
4800, 4840, 48RA, 48RB, SM6AM	1/2"	C38341-810	1/2"	150	5 - 250	FILTER = 2.4 LUBRICATOR = 3.7	7.70	8.70	3.60
SM8AM	1/2"	C38351-810	3/4"	155	5 - 250	FILTER = 2.4 LUBRICATOR = 3.7	7.70	8.70	3.60
34RA, 34RB, MVA034	1/2"	C38461-810	1"	215	5 - 250	FILTER = 5.3 LUBRICATOR = 3.2	10.75	11.10	4.30
551, CCM, DD6M	3/4"	C38451-810	3/4"	199	5 - 250	FILTER = 5.3 LUBRICATOR = 3.2	10.75	11.10	4.30
92RA, 92RB, 92RM, 992RM, EEM, EE5M, HHM, EE3G, EE9G, EE53G, EE59G	1"	C38461-810	1"	215	5 - 250	FILTER = 5.3 LUBRICATOR = 3.2	10.75	11.10	4.30
HH5M	1"	Must use individual units							
KK5B546, KK5B550, KK6M, MMP150, MOV075AA	1/4"	Must use individual units							

## Liquidator Filters

You can depend on Ingersoll Rand and ARO Liquidator Filters™ when you need clean, dry air and your regulator filter can't handle high volumes of liquid contaminants. Note that a lubricator should be installed between the air motor and the liquidator.

### Features

Two stage filtration cartridges remove 99% of liquid contaminants. One micron filter element removes 99% of all dirt particles 1 micron or larger. Quick release bowls enable easy cartridge replacement. Automatic float drain with manual override. Clear polycarbonate bowl with metal guard provides for quick inspection.

### Benefits

- Reduces liquid contaminants
- Increases air motor life
- Cuts maintenance costs

## Lubrication

Proper lubrication of air motors is a must to prevent excessive wear of moving parts; to prevent possible rust and corrosion of bare, unprotected surfaces. Ingersoll Rand oils and greases have been tested thoroughly and are recommended without reservation. Refer to Operation Manuals and Parts Lists for lubrication instructions.

### Liquidator Filters

Female NPT	IR Part Number	Flow Rate scfm	Female NPT	ARO Part Number	Flow Rate scfm
1/4"	8842-W1-035	35	1/4"	F25221-300	40
3/8"	8843-W1-035	35	3/8"	F25231-300	51
1/2"	8844-W1-090	90	1/2"	F25241-300	53
3/4"	8846-W1-090	90	3/4"	F25452-310	50
1"	8828-W2-000*	175	1"	F25462-310	150
1 1/4"	8830-W1-000	400	1 1/4"	F25472-310	150
2"	8834-W1-000	700	—	—	—

\*Two separate canisters

### Filters

## Oils

Part Number	Oil Number	Quantity	Recommended Use
10P	10	1 pt	Fractional horsepower Air Motors
10G	10	1 gal	
50P	50	1 pt	One horsepower and larger Air Motors
50G	50	1 gal	

## Greases

Part Number	Grease Number	Quantity lb.	Recommended Use
28 1 LB	28	1	Motor gearing and bearings
28 8 LB	28	8	

## Air System Components for Pneumatic Motors

### Filters

Motor Series	Motor Inlet Size	Part No.	NPT Size	Flow Rate scfm	Bowl Capacity oz.	Height in.	Width in.	Depth in.
0000	1/8"	F35111-420	1/8"	38	0.70	4.30	2.00	2.00
0	1/8"	F35121-420	1/4"	49	0.70	4.30	2.00	2.00
0, 2200	1/4"	F35221-410	1/4"	73	1.20	6.00	2.30	2.30
44	3/8"	F35331-410	3/8"	150	2.40	7.00	2.80	2.80



### Regulators

Motor Series	Motor Inlet Size	Part No.	NPT Size	Flow Rate scfm	Adj. Pressure Range psi	Height in.	Width in.	Depth in.
0000	1/8"	R37111-600	1/8"	43	5 - 250	3.50	2.90	2.00
0	1/8"	R37121-600	1/4"	55	5 - 250	3.50	2.90	2.00
0, 2200	1/4"	R37221-600	1/4"	73	5 - 250	4.75	2.20	2.70
SM4AM	1/4"	R37231-600	3/8"	84	5 - 250	4.75	2.20	2.70
44	3/8"	R37331-600	3/8"	167	5 - 250	5.50	3.20	2.80



### Lubricators

Motor Series	Motor Inlet Size	Part No.	NPT Size	Flow Rate scfm	Bowl Capacity oz.	Height in.	Width in.	Depth in.
0000	1/8"	L36111-120	1/8"	32	0.50	5.00	2.00	2.00
0	1/8"	L36121-120	1/4"	57	0.50	5.00	2.00	2.00
0, 2200	1/4"	L36221-110	1/4"	51	1.50	6.00	2.25	2.25
SM4AM	1/4"	L36231-110	3/8"	105	1.50	6.00	2.25	2.25
44	3/8"	L36331-110	3/8"	85	4.00	7.70	2.75	2.90



### IR and ARO Combination FRLs (Filter / Regulator / Lubricator)

Motor Series	Motor Inlet Size	Part No.	NPT Size	Flow Rate scfm	Adj. Pressure Range psi	Bowl Capacity oz.	Height in.	Width in.	Depth in.
0000	1/8"	C38111-820	1/8"	34	5 - 250	FILTER = 0.4 LUBRICATOR = 0.4	5.20	4.75	3.20
0	1/8"	C38121-820	1/4"	46	5 - 250	FILTER = 0.4 LUBRICATOR = 0.4	5.20	4.75	3.20
0, 2200	1/4"	C38221-810	1/4"	51	5 - 250	FILTER = 1.2 LUBRICATOR = 1.5	6.60	6.60	3.20
44	3/8"	C38331-810	3/8"	99	5 - 250	FILTER = 2.4 LUBRICATOR = 3.7	7.70	8.70	3.60





## Accessories

### Self-Closing Valves

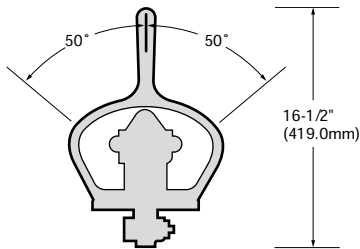

### No. EU-A685

Self-Closing 4-Way Valve. Air inlet pipe tap 3/4" NPT, Motor connection pipe tap 1" NPT, exhaust pipe tap 3/4" NPT.

### Mufflers

Part Number	MALE NPT Size
MRV003A-AF350**	1/8"
MRV015A-AC980*	1/4"
SRA010A1-A212***	3/8"
MRV040A-AC990**	1/2"
MOV010AA-674*	1/2"
3BM-WM07	3/4"
3BM-A674*	1"
150BM-A674*	1 1/4"
SS350-A674*	1 1/2"
ST500-674	2"
SS800-A674*	2 1/2"

\* High scfm Capacity

\*\* Medium scfm Capacity

\*\*\* Low scfm Capacity

### 3/8" Square Drive Adapters

These 3/8" Square Drive Adapters have a 3/8"-24 female thread, for use with Series M002 and M004 Motors equipped with threaded shafts.

Part Number	Description
R1440-212-1	3/8" square drive, 1" long
R1440-212-3	3/8" square drive, 3" long

## Valves

Part Number	Female NPT Size	Flow Rate	Description
E252LM	1/4"	26 scfm	3-Way Hand Lever/Manual Return
E212LM	1/4"	26 scfm	4-Way Hand Lever/Manual Return
E312LS	1/4"	26 scfm	4-Way, 3-Position Hand Lever, Spring Return
K214LM	1/2"	90 scfm	4-Way Hand Lever/Manual Return
K314LS	1/2"	90 scfm	4-Way, 3-Position Hand Lever, Spring Return
M512LR	1/4"	41 scfm	4-Way, 3-Position Rotary Lever, Manual Return
M513LR	3/8"	65 scfm	4-Way, 3-Position Rotary Lever, Manual Return
M514LR	1/2"	85 scfm	4-Way, 3-Position Rotary Lever, Manual Return

### No. K5B-REMOTE

Self-closing 4-Way Valve. Air inlet pipe tap 1 1/2" NPT, Motor connection pipe tap 1 1/2" NPT, exhaust pipe tap 1 1/2" NPT.

### One-Stop Replacement Component Shopping?



ARO® motion control and air preparation components include the Alpha® valve, Economair® cylinder and Module Air® air prep lines. Routinely used throughout industry, these lines have made their own name for their precision, durability and overall efficiency.

[fluids.ingersollrand.com](http://fluids.ingersollrand.com) • 1-800-276-4658



### Tapped Exhaust Deflectors for Piped Away Exhaust

Motor Series	Part Name	Part Number	Pipe Tap NPT
1801	Exhaust Deflector Assembly	R1801-A123	3/4"
1841	Exhaust Deflector Assembly	R1841-A123	3/4"
3800	Exhaust Deflector Assembly	R3800-A123	3/4"
3840	Exhaust Deflector Assembly	R3840-A123	3/4"
4800	Exhaust Deflector Assembly	R4800-A123	1"
4840	Exhaust Deflector Assembly	R4840-A123	1"

## “Special” Air Motors

While there are over 300 standard Air Motors in the complete Ingersoll Rand line, we realize that even this broad selection won't fill every need, every time. Virtually all components of our motors, from output shafts and housings to gear ratios, can be modified. Therefore we welcome the opportunity to design and build Air Motors to our customers' specifications when required.

Generally, yearly quantities of 100 plus are cost-effective. However, the opportunity to quote on lower volumes is always welcomed.

Frequently custom designed Air Motors can reduce OEM costs by easing product assembly, increasing performance, and avoiding the need to make special parts to incorporate the Air Motor in a product. We have the engineering capabilities to provide you with truly “turnkey” power units.

## Installation of Reversible Models



1. 30712 Hex Ball Lock Adapter. 3/8"-24 mounting thread, 1/4" (6.35 mm) hex drive size. See motors on pages 9, 11, 14, 16, and 19.
2. Square-Drive Adapter. See chart below.

Part No.	Mfg. Thd.	Drive Size
30384-5	3/8" 24	3/8"
30384-9	3/8"-24	1/2"
40768	1/2"-20	1/2"

## Recommended Installation for Reversible Models

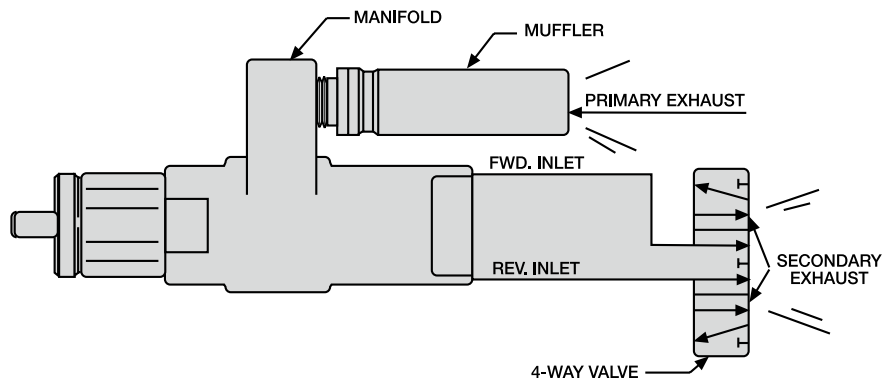

On reversible air motors there are two exhausts. The primary exhaust exhausts air out through the manifold and muffler as in the forward rotation motors. Depending on which direction the motor is running, the opposite inlet port becomes the secondary exhaust and must be opened to atmosphere. A four-way valve, 3-position, spring-centered is recommended for all reversible air motors. An exhaust muffler must be threaded into the exhaust port of each valve to comply with the second level regulations as outlined in the Occupational Safety and Health Act of 1970.

## Warranty

### WARRANTY

#### AIR MOTORS

Ingersoll Rand warrants to the original user its air motors products to be free of defects in material and workmanship for a period of one year from the date of purchase. IR will repair, without cost, any Product found to be defective, including parts and labor charges, or at its option, will replace such Products or refund the purchase price less a reasonable allowance for depreciation, in exchange for the Product. Repairs or replacements are warranted for the remainder of the original warranty period.

If any product proves defective within its original one year warranty period, it should be returned to an appropriate Ingersoll Rand Service Distributor, transportation prepaid with proof of purchase or warranty card.

This warranty does not apply to Products which IR has determined to have been misused or abused, improperly maintained by the purchaser, or where the malfunction or defect can be attributed to the use of non-genuine IR parts.

IR makes no other warranty, and all implied warranties including any warranty of merchantability or fitness for a particular purpose are limited to the duration of the expressed warranty period as set for the above. IR's maximum liability is limited to the purchase price of the Product and in no event shall IR be liable for any consequential, indirect, incidental, or special damages of any nature arising from the sale or use of the Product, whether based on contract, tort, or otherwise.

# Index

## Model Number Page

### 0

0-Series.....	19, 64
0/2200-Series.....	22
000-Series.....	14, 62

### 1

10G.....	85
10P.....	85
150BM-A674.....	87
17RA005.....	41
17RA008.....	41
17RA014.....	41
17RA017.....	41
17RA022.....	41
17RB029.....	41
17RB036.....	41
17RB045.....	41
17RB078.....	41
1801N.....	33, 34
1801P.....	33, 34
1801Q.....	33, 34
1801U.....	33, 34
1801W.....	33, 34
1841N.....	33, 34
1841P.....	33, 34
1841Q.....	33, 34
1841U.....	33, 34
1841W.....	33, 34

### 2

2200/44-Series.....	31
2200-Series.....	27, 29, 66, 67, 68
22N51-W/RC.....	71
28 1 LB.....	85
28 8 LB.....	85

### 3

30018.....	27, 29
30384-5.....	9, 14, 19
30384-9.....	9, 14, 19
30712.....	9, 14, 19
31651.....	27, 29
31812-1.....	62, 64
31812-2.....	62, 64
31812-3.....	62, 64
31812-4.....	62, 64
31812-5.....	62, 64
31812-6.....	62, 64
31812-7.....	62, 64
31812-8.....	62, 64
32968-1.....	66
32968-2.....	66

## Model Number Page

32968-3.....	66
32968-4.....	66
32968-5.....	66
32968-6.....	66
32968-7.....	66
32968-8.....	66
32968-9.....	66
33907.....	27, 29
34RA005.....	41
34RA008.....	41
34RA011.....	41
34RA014.....	41
34RA017.....	41
34RA022.....	41
34RB029.....	41
34RB036.....	41
34RB045.....	41
34RB078.....	41
35264-1.....	70
35264-2.....	70
35264-3.....	70
35264-4.....	70
35264-5.....	70
35264-6.....	70
35264-7.....	70
35264-8.....	70
35264-9.....	70
37892-1.....	31, 37
37893.....	27
37894.....	27
37895-1.....	21, 29
37896.....	19
37897.....	19
37898.....	14
37899.....	14
3800M.....	35, 36
3800P.....	35, 36
3800Q.....	35, 36
3800R.....	35, 36
3800S.....	35, 36
3800U.....	35, 36
3840M.....	35, 36
3840P.....	35, 36
3840Q.....	35, 36
3840R.....	35, 36
3840S.....	35, 36
3840U.....	35, 36
3BM-A674.....	86
3BM-WM07.....	86

### 4

40768.....	27, 29
41057.....	9
41058.....	9
41512.....	31, 37
41512-1.....	31, 37

# Index

<b>Model Number</b>	<b>Page</b>	<b>Model Number</b>	<b>Page</b>
41557	70	7537-C	14
41559	66, 67	7538-B	14
41561	64	7539-B	14
41563	62, 63	7540-B	14
41784	31, 37	7541-B	14
42420	14, 19	7542-C	14
44-Series	37, 70	7543-B	14
45057	64	7544-B	14
45058	66, 67	7545-B	14
45088	62, 63	7546-B	14
45090	70	7547-C	14
47340	9, 14	7800-1B	29
47341	19	7800-2B	66, 67
4800D	39, 40	7800-3B	68
4800K	39, 40	7800-4B	68, 69
4800M	39, 40	7800-B	27
4800N	39, 40	7801-1B	29
4800P	39, 40	7801-2B	66, 67
4800Q	39, 40	7801-3B	68, 69
4800S	39, 40	7801-4B	68, 69
4800U	39, 40	7801-B	27
4840D	39, 40	7802-1B	29
4840K	39, 40	7802-2B	66, 67
4840M	39, 40	7802-3B	69
4840N	39, 40	7802-4B	68, 69
4840P	39, 40	7802-B	27
4840Q	39, 40	7803-1B	29
4840S	39, 40	7803-2B	66, 67
4840U	39, 40	7803-3B	68, 69
48RA005	43	7803-4B	68, 69
48RA008	43	7803-B	27
48RA011	43	7804-1B	29
48RA014	43	7804-2B	66, 67
48RA017	43	7804-3B	68, 69
48RA022	43	7804-4B	68
48RB029	43	7804-B	27
48RB036	43	7805-1B	29
48RB045	43	7805-2B	67
48RB078	43	7805-3B	68, 69
		7805-4B	68, 69
		7805-B	27
		7806-1B	29
		7806-B	27
		7807-1B	29
		7807-B	27
		7808-1B	29
		7808-B	27
		7809-1B	29
		7809-B	27
		7810-1B	29
		7810-B	27
		7811-1B	29
		7811-B	27
		7812-1B	29
		7812-B	27
		7813-1B	29
		7813-B	27
7533-2-B	62, 63		
7533-B	14		
7534-2-B	62, 63		
7534-B	14		
7535-2-C	62, 63		
7535-C	14		
7536-2-B	62, 63		
7536-B	14		
7537-2-C	62, 63		

## 5

50G	85
50P	85
551SM51-W/RC	73
551SO51-W/RC	73

## 7

7533-2-B	62, 63
7533-B	14
7534-2-B	62, 63
7534-B	14
7535-2-C	62, 63
7535-C	14
7536-2-B	62, 63
7536-B	14
7537-2-C	62, 63

# Index

<b>Model Number</b>	<b>Page</b>	<b>Model Number</b>	<b>Page</b>
7814-1B	29	8229-3A	19
7814-B	27	8229-4A	19
7815-1B	29	8229-5A	19
7815-B	27	8229-6A	19
7816-1B	29	8229-7A	19
7816-B	27	8229-8A	19
7817-1B	29	8229-9A	19
7817-B	27	8230-1A	19
<b>8</b>			
8200-4A	71	8230-2A	19
8200-4A-( )	70	8230-3A	19
8200-A	32, 38	8230-4A	19
8201-4A	71	8230-5A	19
8201-4A-( )	70	8230-6A	19
8201-A	37, 38	8230-7A	19
8202-4A	71	8230-8A	19
8202-4A-( )	70	8230-9A	19
8202-A	37, 38	8231-1B	19
8203-4A	71	8231-2B	19
8203-4A-( )	70	8231-3B	19
8203-A	38	8231-4B	19
8204-4A	71	8231-5B	19
8204-4A-( )	70	8231-6B	19
8204-A	37, 38	8231-7B	19
8205-4A	71	8231-8B	19
8205-4A-( )	70	8231-9B	19
8205-A	37, 38	8232-( )	65
8206-A	37, 38	8232-1	64
8207-A	37, 38	8232-2	64
8208-A	37, 38	8232-3	64
8209-A	37, 38	8232-4	64
8210-A	37, 38	8232-5	64
8211-A	37, 38	8232-6	64
8226-10A	21	8232-7	64
8226-11A	21	8274-1A	31
8226-12A	21	8274-2A	31
8226-13A	21	8274-3A	31
8226-14A	21	8274-4A	31
8226-6A	21	8274-5A	31
8226-7A	21	8274-6A	31
8226-8A	21	8274-A	31
8228-10B	21	8276-1A	31
8228-11B	21	8276-2A	31
8228-12B	21	8276-3A	31
8228-13B	21	8276-4A	31
8228-14B	21	8276-5A	31
8228-2B	21	8276-6A	31
8228-3B	21	8610-A	9
8228-5B	21	8611-A	9
8228-6B	21	8613-A	9
8228-7B	21	8614-A	9
8228-8B	21	8616-A	9
8228-9B	21	8617-A	9
8229-1A	19	8618-A	9
8229-2A	19	8828-W2-000	85
		8830-W1-000	85
		8834-W1-000	85
		8842-W1-035	85



# Index

Model Number	Page
8843-W1-035.....	85
8844-W1-090.....	85
8846-W1-090.....	85

## 9

92RA005.....	45
92RA008.....	45
92RA011.....	45
92RA014.....	45
92RA017.....	45
92RA022.....	45
92RB029.....	45
92RB036.....	45
92RB045.....	45
92RB078.....	45
92RM1.....	47
92RM2.....	47
992RM1.....	47

## C

C38111-820.....	86
C38121-820.....	85, 86
C38221-810.....	85, 86
C38231-810.....	85
C38331-810.....	85, 86
C38341-810.....	85
C38351-810.....	85
C38451-810.....	85
C38461-810.....	85
CCM.....	74, 78

## D

DD6M.....	74, 78
-----------	--------

## E

E212LM.....	87
E252LM.....	87
E312LM.....	87
EE3G.....	74, 78
EE53G.....	74, 78
EE59G.....	74, 78
EE5M.....	74, 78
EE9G.....	74, 78
EEM.....	74, 78

## F

F35-0B-C28.....	84
F35111-420.....	86
F35121-420.....	84, 86
F35221-410.....	84, 86
F35231-410.....	84
F35331-410.....	84, 86
F35341-410.....	84
F35351-410.....	84

Model Number	Page
F35451-410.....	84
F35461-410.....	84
F42-0A-000.....	84

## H

HH5M.....	74, 78
HHM.....	74, 78

## K

K214LM.....	87
K314LS.....	87
K5B - Foot.....	82
K5B - Manual.....	82
K5B - NEMA - 213.....	82
K5B - Pilot.....	82
K5B - Shaft - 1.625.....	82
KK5B546.....	81, 82
KK5B550.....	81, 82
KK5B550-B2A0A.....	82
KK5B550-B2B0A.....	82
KK6M.....	74, 78

## L

L36111-120.....	86
L36121-120.....	84, 86
L36221-110.....	84, 86
L36231-110.....	84, 86
L36331-110.....	84, 86
L36341-110.....	84
L36351-110.....	84
L36451-110.....	84
L36461-110.....	84
L40-0A-000.....	84
L40-0B-000.....	84

## M

M002RHR000AR3.....	11
M002RHR004AR3.....	11
M002RHR006AR3.....	11
M002RHR008AR3.....	11
M002RHR013AR3.....	11
M002RHR021AR3.....	11
M002RHR028AR3.....	11
M002RHR044AR3.....	11
M002RHR101AR3.....	11
M002RHR159AR3.....	11
M002RVR000AR3.....	11
M002RVR004AR3.....	11
M002RVR006AR3.....	11
M002RVR008AR3.....	11
M002RVR013AR3.....	11
M002RVR021AR3.....	11
M002RVR028AR3.....	11
M002RVR044AR3.....	11

## Index

Model Number	Page	Model Number	Page
M002RVR101AR3	11	M514LR	87
M002RVR159AR3	11	MLK-K269C	82
M004RHR000AR3	16	MOV005AA	49,51,52
M004RHR004AR3	16	MOV010AA-674	87
M004RHR006AR3	16	MOV075AA	49,52
M004RHR011AR3	16	MRV003	53
M004RHR015AR3	16	MRV003A-AF350	87
M004RHR023AR3	16	MRV005	53
M004RHR033AR3	16	MRV009	53
M004RHR050AR3	16	MRV015	53
M004RHR083AR3	16	MRV015A-AC980	87
M004RHR167AR3	16	MRV040	53
M004RVR000AR3	16	MRV040A-AC990	87
M004RVR004AR3	16	MRV050	53
M004RVR006AR3	16	MVA017A	49,52
M004RVR011AR3	16	MVA017B	49,52
M004RVR015AR3	16	MVA034A	49,52
M004RVR023AR3	16	MVA034B	49,52
M004RVR033AR3	16		
M004RVR050AR3	16		
M004RVR083AR3	16		
M004RVR167AR3	16		
M007RHR000AR4	23		
M007RHR004AR4	23		
M007RHR006AR4	23		
M007RHR009AR4	23		
M007RHR012AR4	23		
M007RHR015AR4	23		
M007RHR021AR4	23		
M007RHR027AR4	23		
M007RHR037AR4	23		
M007RHR044AR4	23		
M007RHR063BR6	23		
M007RHR086BR6	23		
M007RHR119BR6	23		
M007RHR151BR6	23		
M007RHR188BR6	23		
M007RHR275BR6	23		
M007RHR374BR6	23		
M007RVR000AR4	23		
M007RVR004AR4	23		
M007RVR006AR4	23		
M007RVR009AR4	23		
M007RVR012AR4	23		
M007RVR015AR4	23		
M007RVR021AR4	23		
M007RVR027AR4	23		
M007RVR037AR4	23		
M007RVR044AR4	23		
M007RVR063BR6	23		
M007RVR086BR6	23		
M007RVR119BR6	23		
M007RVR151BR6	23		
M007RVR188BR6	23		
M007RVR275BR6	23		
M007RVR374BR6	23		
M512LR	87		
M513LR	87		
		<b>R</b>	
		R1440-212-1	87
		R1440-212-3	87
		R1801-A123	87
		R37111-600	86
		R37121-600	84,86
		R37221-600	84,86
		R37231-600	84,86
		R37331-600	84,86
		R37341-600	84
		R37351-600	84
		R37451-600	84
		R37461-600	84
		R30-0A-G00	84
		R30-0A-G01	84
		R3800-A123	87
		R40-0B-G00	84
		R4800-A123	87
		<b>S</b>	
		Series 17RA, 17RB, 34RA, 34RB	41
		Series 1801 and 1841	33
		Series 3800 and 3840	35
		Series 4800 and 4840	39
		Series 48RA and 48RB	43
		Series 551	73
		Series 92RA and 92RB	45
		Series 92RM and 992RM	47
		Series M002	11
		Series M004	16
		Series M007	23
		Series MVA	49
		Series MRV	53
		<b>U</b>	
		UWD -A686	82

## Notes

## Notes

**United States***Ingersoll Rand*

Tel: +1-800-TOOLHLP

Fax: +1-615-672-7678

**Mexico***Ingersoll Rand S.A. de C.V. Ingersoll Rand do Brasil Ltda*

Tel: +52 55 5005-6600

Fax: +52 55 5565-3072

**Brazil***Ingersoll Rand do Brasil Ltda*

Tel: +55 11 2109-8900

Fax: +55 11 2109-8998

**Canada***Ingersoll Rand Canada*

Tel: +1-800-TOOLHLP

Fax: +1-416-213-4510

**Chile***Ingersoll Rand Chile*

Tel: +56 2 444-6800

Fax: +56 2 485-8303

**United Kingdom  
& Ireland***Ingersoll Rand Sales Co. Ltd. Ingersoll Rand GmbH*

Tel: +44 1942 257171

Fax: +44 1942 503451

**Germany, Austria,  
& Switzerland***Ingersoll Rand GmbH*

Tel: +49 208 999 4422

Fax: +49 208 999 4444

**Belgium, Netherlands, Middle East &  
& Luxembourg Northern Africa***Ingersoll Rand*

Tel: +33 8 10 22 27 77

Fax: +33 1 30 07 69 80

*Ingersoll Rand*

Tel: +971 (0) 43313984

Fax: +971 (0) 43313032

**France***Ingersoll Rand*

Tel: +33 8 10 22 27 77

Fax: +33 1 30 07 69 80

**Scandinavia***Ingersoll Rand*

Tel: +46 40 162062

Fax: +46 40 162065

**Greece***Ingersoll Rand*

Tel: +33 1 30 07 69 60

Fax: +33 1 30 07 69 80

**Italy***Ingersoll Rand Italiana Spa*

Tel: +39 (0) 2 950561

Fax: +39 (0) 2 95360159

**Spain and Portugal***Ingersoll Rand Iberica*

Tel: +34 91 6277405

Fax: +34 91 6277406

**Russia and CIS***Ingersoll Rand*

Tel: +7 495 663 82 67

Fax: +7 495 785 21 26

**Poland***Ingersoll Rand*

Tel: +48 22 635 72 45

Fax: +48 22 635 73 32

**Sub-Saharan Africa***Ingersoll Rand*

Tel: +27 11 864 3930

Fax: +27 11 864 3954

**Estonia, Latvia,  
and Lithuania***Ingersoll Rand*

Tel: +371 29 931060 (Riga)

Fax: +48 22 635 73 32

**Czech Republic,  
Slovakia & Hungary***Ingersoll Rand*

Tel: +420 2 57 109 756

Fax: +420 2 57 109 758

**Slovenia,  
Bosna & Croatia***Ingersoll Rand*

Tel: +359 2 961 79 65

Fax: +359 2 961 79 69

**Bulgaria, Romania,  
Serbia & Montenegro***Ingersoll Rand*

Tel: +359 2 961 79 65

Fax: +359 2 961 79 69

**Korea***Ingersoll Rand Korea*

Tel: +82-2-3660-6800

Fax: +82-2-3141-8010

**China***Shanghai Service Center*

Tel: +86-21-5691-1778

Fax: +86-21-5691-1779

**Malaysia***Ingersoll Rand Malaysia Co.**Sdn.Bhd.*

Tel: +60-3-5633-3322

Fax: +60-3-5634-5911

**India***Ingersoll Rand Wadco Tools**Pvt. Limited*

Tel: +91-120-4389200

Fax: +91-120-4389444

**Singapore***Ingersoll Rand**South East Asia (Pte) Ltd.*

Tel: +65-6860-6800

Fax: +65-6862-1373

**Australia***Ingersoll Rand (Australia)**Ltd.*

Tel: +61-3-8787-4300

Fax: +61-3-8787-5510

**Japan***Ingersoll Rand Japan**Ltd.*

Tel: +81-3-5420-3392

Fax: +81-3-5420-9116

Distributed by:



Ingersoll Rand Industrial Technologies provides products, services and solutions that enhance our customers' energy efficiency, productivity and operations. Our diverse and innovative products range from complete compressed air systems, tools and pumps to material and fluid handling systems and environmentally friendly microturbines. We also enhance productivity through solutions created by Club Car®, the global leader in golf and utility vehicles for businesses and individuals.

(866) 207-6923 • [irtools.com](http://irtools.com)